

**PILOT'S OPERATING HANDBOOK  
AND FAA APPROVED  
AIRPLANE FLIGHT MANUAL  
for the  
CIRRUS DESIGN SR22**



FAA Approved in Normal Category based on FAR 23. This document must be carried in the airplane at all times and be kept within the reach of the pilot during all flight operations.

THIS HANDBOOK INCLUDES THE MATERIAL REQUIRED TO BE FURNISHED TO THE PILOT BY FAR PART 23 AND ADDITIONAL INFORMATION PROVIDED BY CIRRUS DESIGN AND CONSTITUTES THE FAA APPROVED AIRPLANE FLIGHT MANUAL

Model - Serial Num. SR22-\_\_\_\_\_ Registration Num. \_\_\_\_\_

FAA Approved Joseph C. Miss Date Oct 10 2003  
Royace H. Prather, Manager  
Chicago Aircraft Certification Office, ACE-115C  
Federal Aviation Administration

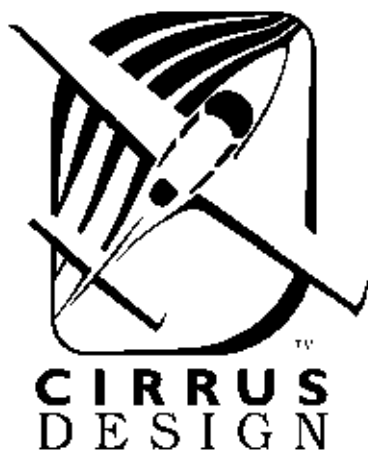

Copyright © 2003 - All Rights Reserved  
Cirrus Design Corporation  
4515 Taylor Circle  
Duluth, MN 55811

## Foreword

This Pilot's Operating Handbook (POH or Handbook) has been prepared by Cirrus Design Corporation to familiarize operators with the Cirrus Design SR22 airplane. Read this Handbook carefully. It provides operational procedures that will assure the operator obtains the performance published in the manual, data designed to allow the most efficient use of the airplane, and basic information for maintaining the airplane in a "like new" condition.

• Note •

All limitations, procedures, maintenance & servicing requirements, and performance data contained in this Handbook are mandatory for compliance with FAA operating rules and for continued airworthiness of the airplane.

This Handbook includes the material required to be furnished to the pilot by the Federal Aviation Regulations (FARs) and additional information provided by Cirrus Design Corporation and constitutes the FAA Approved Airplane Flight Manual for the Cirrus Design SR22.

## The Handbook

This Pilot's Operating Handbook has been prepared using GAMA Specification #1 for Pilot's Operating Handbook, Revision 2, dated 18 October 1996 as the content model and format guide. However, some deviations from this specification were made for clarity. The Handbook is presented in loose-leaf form for ease in inserting revisions and is sized for convenient storage. Tabbed dividers throughout the Handbook allow quick reference to each section. Logical and convenient Tables of Contents are located at the beginning of each section to aid in locating specific data within that section. The Handbook is divided into ten sections as follows:

Section 1.....	General
Section 2.....	Limitations
Section 3.....	Emergency Procedures
Section 4.....	Normal Procedures
Section 5.....	Performance Data
Section 6.....	Weight & Balance/Equipment List
Section 7.....	Airplane & Systems Description
Section 8.....	Handling, Servicing & Maintenance
Section 9.....	Supplements
Section 10.....	Safety Information

The data presented in this Handbook is the result of extensive flight tests and is approved by the Federal Aviation Administration. However, as new procedures or performance data are developed, they will be sent to the owner of record for each airplane.

• Note •

It is the responsibility of the owner to ensure that the Pilot's Operating Handbook is current at all times. Therefore, it is very important that all revisions be properly incorporated into this Handbook as soon as they are received.

## Revising the Handbook

Two types of revisions may be issued for this Handbook: Numbered and Temporary.

**Temporary revisions** are printed on yellow paper, normally cover only one topic or procedure, and are issued to provide safety related information or other time sensitive information where the rigor of providing a numbered revision is not possible in the time allowed. All the information needed to properly file a temporary revision is included on the revision itself. Typically, a temporary revision is superseded and replaced by the next numbered revision. A "Log of Temporary Revisions" following the "List of Effective Pages" is provided to log temporary revisions when they are issued. Typically, the "Log of Temporary Revisions" is replaced at the next numbered revision.

**Numbered revisions** are printed on white paper, normally cover several subjects, and are issued as general updates to the Handbook. Each numbered revision includes an "Instruction Sheet," a "List of Effective Pages", and a "Revision Highlights" page. The "Instruction Sheet" is intended to assist the manual holder in removing superseded pages and inserting new or superseding pages. The "List of Effective Pages" shows the issue or revision status of all pages in the Handbook. The "Revision Highlights" page gives a brief description of changes made to each page in the current revision.

## Identifying Revised Material

Each page in the Handbook has revision identification at the lower inside corner opposite the page number. Original issue pages will be identified by the words "Original Issue" at this location. In the event that the majority of pages in the Handbook are revised, Cirrus may determine that it is more effective to reissue the Handbook. Reissued pages will be identified by the word "Reissue" followed by a letter indicating the reissue level; for example, "Reissue A" Revised pages will be identified by the word "Revision" followed by the revision number at this location; for example, "Revision 2" (Original Issue, Revision 2) or "Revision B1" (Reissue B, Revision 1).

Revised material on a page can be identified by a change bar located at the outside page margin. See the outside margin of this page adjacent to this paragraph for an example. Revision bars are not used at reissues of the Handbook.

## Revision Service

Revision service for this Handbook is provided at no cost for the Pilot's Operating Handbook and FAA Approved Airplane Flight Manual assigned to an airplane. Additional copies of the Handbook and revision service can be obtained from Customer Service at Cirrus Design at the address below.

• Note •

If at any time it is found that the Handbook is not current, temporary revisions are missing, or applicable supplements are not included, contact Customer Service at Cirrus Design immediately.

Customer Service  
Cirrus Design Corporation  
4515 Taylor Circle  
Duluth, MN 55811  
Phone: (218) 727-2737  
Fax: (218) 727-2148

## Supplements

The Supplements section (Section 9) of this Handbook contains FAA Approved Supplements necessary to safely and efficiently operate the SR22 when equipped with optional equipment not provided with the standard airplane or not included in the Handbook. Supplements are essentially "mini-handbooks" and may contain data corresponding to most sections of the Handbook. Data in a supplement either adds to, supersedes, or replaces similar data in the basic Handbook.

Section 9 includes a "Log of Supplements" page preceding all Cirrus Design Supplements produced for this airplane. The "Log of Supplements" page can be utilized as a "Table of Contents" for Section 9. If the airplane is modified at a non Cirrus Design facility through an STC or other approval method, it is the owner's responsibility to ensure that the proper supplement, if applicable, is installed in the Handbook and that the supplement is properly recorded on the "Log of Supplements" page.

## Retention of Data

In the event a new title page is issued, the weight and balance data changes, equipment list changes, or the "Log of Supplements" is replaced, the owner must ensure that all information applicable to the airplane is transferred to the new pages and the aircraft records are current. It is not a requirement that owners retain information, such as supplements, that is not applicable to their airplane.

## Warnings, Cautions, and Notes

Warnings, Cautions, and Notes are used throughout this Handbook to focus attention on special conditions or procedures as follows:

### • **WARNING** •

Warnings are used to call attention to operating procedures which, if not strictly observed, may result in personal injury or loss of life.

### • **Caution** •

Cautions are used to call attention to operating procedures which, if not strictly observed, may result in damage to equipment.

### • **Note** •

Notes are used to highlight specific operating conditions or steps of a procedure.

Intentionally Left Blank



# **Section 1**

## **General**

### **Table of Contents**

Introduction .....	1-3
The Airplane.....	1-6
Engine.....	1-6
Propeller .....	1-6
Fuel.....	1-6
Oil .....	1-7
Maximum Certificated Weights .....	1-7
Cabin and Entry Dimensions .....	1-7
Baggage Spaces and Entry Dimensions .....	1-7
Specific Loadings.....	1-7
Symbols, Abbreviations and Terminology.....	1-8
General Airspeed Terminology and Symbols .....	1-8
Meteorological Terminology.....	1-9
Engine Power Terminology.....	1-10
Performance and Flight Planning Terminology.....	1-10
Weight and Balance Terminology.....	1-11

Intentionally Left Blank

## Introduction

This section contains information of general interest to pilots and owners. You will find the information useful in acquainting yourself with the airplane, as well as in loading, fueling, sheltering, and handling the airplane during ground operations. Additionally, this section contains definitions or explanations of symbols, abbreviations, and terminology used throughout this handbook.

• Note •

For specific information regarding the organization of this Handbook, revisions, supplements, and procedures to be used to obtain revision service for this handbook, *refer to the "Foreword" immediately following the title page*

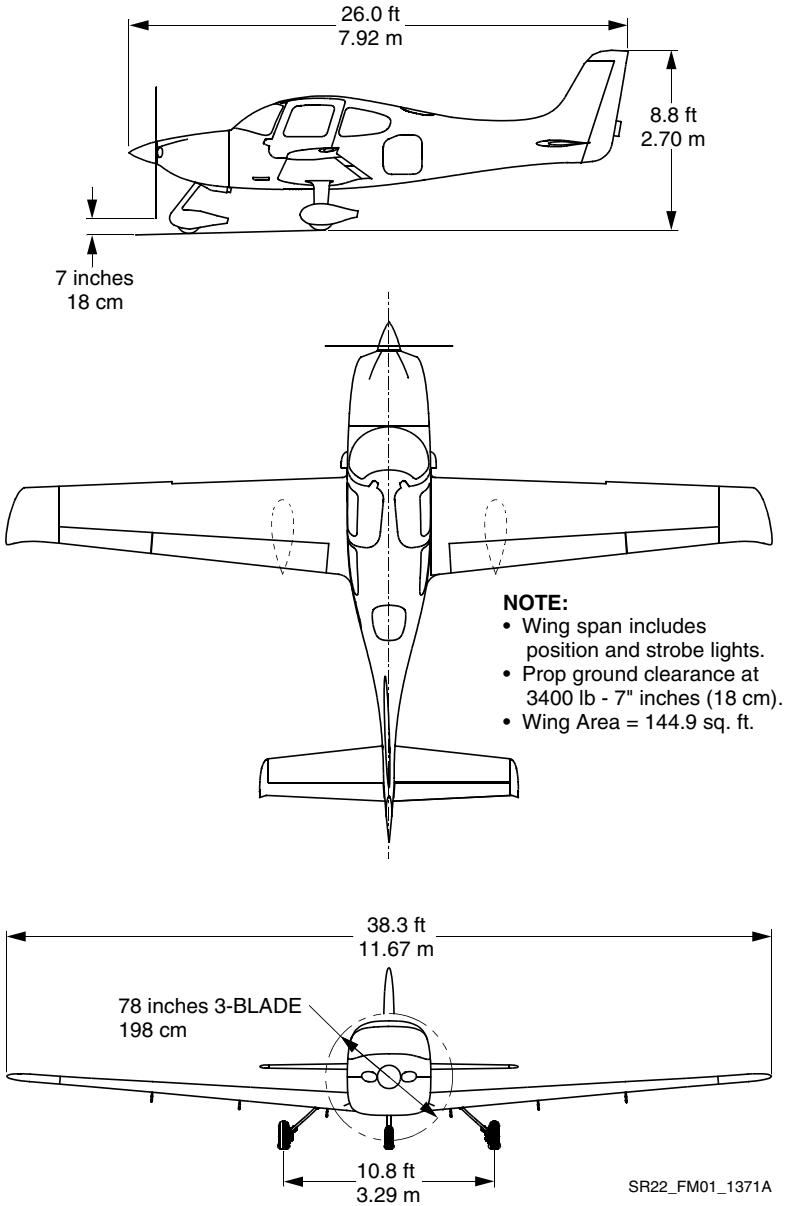

**Figure 1-1**  
**Airplane Three View**

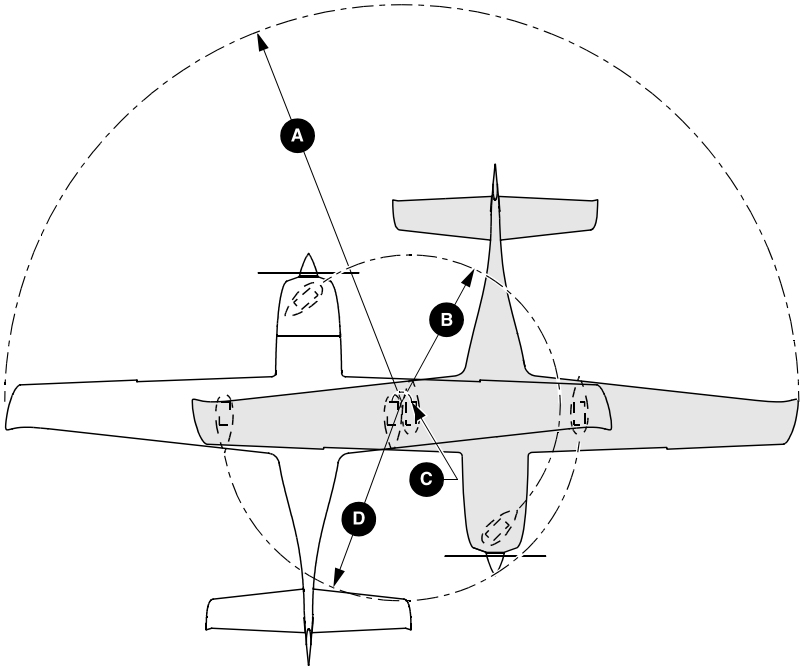

**GROUND TURNING CLEARANCE**

- A** -RADIUS FOR WING TIP ----- 24.8 ft. (7.54 m)
- B** -RADIUS FOR NOSE GEAR ----- 7.0 ft. (2.16 m)
- C** -RADIUS FOR INSIDE GEAR ----- 0.5 ft. (.15 m)
- D** -RADIUS FOR OUTSIDE GEAR ----- 10.8 ft. (3.30 m)

TURNING RADII ARE CALCULATED USING ONE BRAKE AND PARTIAL POWER. ACTUAL TURNING RADIUS MAY VARY AS MUCH AS THREE FEET.

SR22\_FM01\_1370

**Figure 1-2**  
**Turning Radius**

# The Airplane

## Engine

Number of Engines..... 1  
Number of Cylinders.....6  
Engine Manufacturer ..... Teledyne Continental  
Engine Model..... IO-550-N  
Fuel Metering..... Fuel Injected  
Engine Cooling ..... Air Cooled  
Engine Type.....Horizontally Opposed, Direct Drive  
Horsepower Rating.....310 hp @ 2700 rpm

## Propeller

### *Hartzell*

Propeller Type..... Constant Speed, Three Blade  
Model Number .....PHC-J3YF-1RF/F7694  
Diameter ..... 78.0" (76.5" Minimum)  
Model Number .....PHC-J3YF-1RF/F7693DF  
Diameter ..... 78.0" (76.5" Minimum)

*or*

### *McCaughey*

Propeller Type..... Constant Speed, Three Blade  
Model Number ..... D3A34C443/78CYA-0  
Diameter ..... 78.0" (76.5" Minimum)

## Fuel

Total Capacity .....84.0 U.S. Gallons (318.0 L)  
Total Usable .....81.0 U.S. Gallons (306.6 L)  
Approved Fuel Grades:  
100 LL Grade Aviation Fuel (Blue)  
100 (Formerly 100/130) Grade Aviation Fuel (Green)

## Oil

Oil Capacity (Sump) ..... 8 U.S. Quarts (7.6 L)

Oil Grades:

All Temperatures ..... SAE 15W-50, 20W-50, or 20W-60

Below 40 °F (4° C)..... SAE 30

Above 40 °F (4° C) ..... SAE 50

## Maximum Certificated Weights

Maximum Gross for Takeoff..... 3400 lb (1542 Kg)

Maximum Baggage Compartment Loading..... 130 lb (59 Kg)

Standard Empty Weight ..... 2250 lb (1021 Kg)

Maximum Useful Load..... 1150 lb (522 Kg)

Full Fuel Payload..... 676 lb (307 Kg)

## Cabin and Entry Dimensions

Dimensions of the cabin interior and entry door openings are illustrated in detail in Section 6.

## Baggage Spaces and Entry Dimensions

Dimensions of the baggage area and baggage door opening are illustrated in detail in Section 6.

## Specific Loadings

Wing Loading ..... 23.5 lb per square foot

Power Loading..... 11.0 lb per hp

# Symbols, Abbreviations and Terminology

## General Airspeed Terminology and Symbols

**KCAS** **Knots Calibrated Airspeed** is the indicated airspeed corrected for position and instrument error. Calibrated airspeed is equal to true airspeed in standard atmosphere at sea level.

**KIAS** **Knots Indicated Airspeed** is the speed shown on the airspeed indicator. The IAS values published in this handbook assume no instrument error.

**KTAS** **Knots True Airspeed** is the airspeed expressed in knots relative to undisturbed air which is KCAS corrected for altitude and temperature.

**V<sub>O</sub>** **Operating Maneuvering Speed** is the maximum speed at which application of full control movement will not overstress the airplane.

**V<sub>FE</sub>** **Maximum Flap Extended Speed** is the highest speed permissible with wing flaps in a prescribed extended position.

**V<sub>NO</sub>** **Maximum Structural Cruising Speed** is the speed that should not be exceeded except in smooth air, and then only with caution.

**V<sub>NE</sub>** **Never Exceed Speed** is the speed that may not be exceeded at any time.

**V<sub>PD</sub>** **Maximum Demonstrated Parachute Deployment Speed** is the maximum speed at which parachute deployment has been demonstrated.

**V<sub>S</sub>** **Stalling Speed** is minimum steady flight speed at which the aircraft is controllable.

**V<sub>S 50%</sub>** **Stalling Speed** is minimum steady flight speed at which the aircraft is controllable with 50% flaps.

**V<sub>SO</sub>** **Stalling Speed** is the minimum steady flight speed at which the aircraft is controllable in the landing configuration (100% flaps) at the most unfavorable weight and balance.



- $V_X$  **Best Angle of Climb Speed** is the speed which results in the greatest gain of altitude in a given horizontal distance.
- $V_Y$  **Best Rate of Climb Speed** is the speed which results in the greatest gain of altitude in a given time.

## Meteorological Terminology

- IMC** **Instrument Meteorological Conditions** are meteorological conditions expressed in terms of visibility, distance from cloud, and ceiling less than the minima for visual flight defined in FAR 91.155.
- ISA** **International Standard Atmosphere** (standard day) is an atmosphere where (1) the air is a dry perfect gas, (2) the temperature at sea level is 15° C, (3) the pressure at sea level is 29.92 in.Hg (1013.2 millibars), and (4) the temperature gradient from sea level to the altitude at which the temperature is -56.5° C is -0.00198° C per foot and zero above that altitude.
- MSL** **Mean Sea Level** is the average height of the surface of the sea for all stages of tide. In this Handbook, altitude given as MSL is the altitude above the mean sea level. It is the altitude read from the altimeter when the altimeter's barometric adjustment has been set to the altimeter setting obtained from ground meteorological sources.
- OAT** **Outside Air Temperature** is the free air static temperature obtained from inflight temperature indications or from ground meteorological sources. It is expressed in either degrees Celsius or degrees Fahrenheit.
- **Pressure Altitude** is the altitude read from the altimeter when the altimeter's barometric adjustment has been set to 29.92 in.Hg (1013 mb) corrected for position and instrument error. In this Handbook, altimeter instrument errors are assumed to be zero.

- **Standard Temperature** is the temperature that would be found at a given pressure altitude in the standard atmosphere. It is 15° C (59° F) at sea level pressure altitude and decreases approximately 2° C (3.6° F) for each 1000 feet of altitude increase. See ISA definition.

## Engine Power Terminology

- HP **Horsepower** is the power developed by the engine.
- MCP **Maximum Continuous Power** is the maximum power that can be used continuously.
- MAP **Manifold Pressure** is the pressure measured in the engine's induction system expressed as in. Hg.
- RPM **Revolutions Per Minute** is engine rotational speed.
- **Static RPM** is RPM attained during a full-throttle engine runup when the airplane is on the ground and stationary.

## Performance and Flight Planning Terminology

- g One "g" is a quantity of acceleration equal to that of earth's gravity.
- **Demonstrated Crosswind Velocity** is the velocity of the crosswind component for which adequate control of the airplane during taxi, takeoff, and landing was actually demonstrated during certification testing. Demonstrated crosswind is not considered to be limiting.
  - **Service Ceiling** is the maximum altitude at which the aircraft at maximum weight has the capability of climbing at a rate of 100 feet per minute.
- GPH **Gallons Per Hour** is the amount of fuel (in gallons) consumed by the aircraft per hour.
- NMPG **Nautical Miles Per Gallon** is the distance (in nautical miles) which can be expected per gallon of fuel consumed at a specific engine power setting and/or flight configuration.

- **Unusable Fuel** is the quantity of fuel that cannot be safely used in flight.
- **Usable Fuel** is the fuel available for flight planning.

## Weight and Balance Terminology

c.g. **Center of Gravity** is the point at which an airplane would balance if suspended. Its distance from the reference datum is found by dividing the total moment by the total weight of the airplane.

- **Arm** is the horizontal distance from the reference datum to the center of gravity (c.g.) of an item. The airplane's arm is obtained by adding the airplane's individual moments and dividing the sum by the total weight.
- **Basic Empty Weight** is the actual weight of the airplane including all operating equipment that has a fixed location in the airplane. The basic empty weight includes the weight of unusable fuel and full oil.

MAC **Mean Aerodynamic Chord** is the chord drawn through the centroid of the wing plan area.

LEMAC **Leading Edge of Mean Aerodynamic Chord** is the forward edge of MAC given in inches aft of the reference datum (fuselage station).

- **Maximum Gross Weight** is the maximum permissible weight of the airplane and its contents as listed in the aircraft specifications.
- **Moment** is the product of the weight of an item multiplied by its arm.
- **Useful Load** is the basic empty weight subtracted from the maximum weight of the aircraft. It is the maximum allowable combined weight of pilot, passengers, fuel and baggage.
- **Station** is a location along the airplane fuselage measured in inches from the reference datum and expressed as a number. For example: A point 123 inches aft of the reference datum is Fuselage Station 123.0 (FS 123).

- **Reference Datum** is an imaginary vertical plane from which all horizontal distances are measured for balance purposes.
- **Tare** is the weight of all items used to hold or position the airplane on the scales for weighing. Tare includes blocks, shims, and chocks. Tare weight must be subtracted from the associated scale reading.

# **Section 2**

## **Limitations**

### **Table of Contents**

Introduction .....	2-3
Certification Status .....	2-3
Airspeed Limitations .....	2-4
Airspeed Indicator Markings .....	2-5
Power Plant Limitations .....	2-6
Engine .....	2-6
Propeller .....	2-7
Instrument Markings .....	2-8
General Limitations .....	2-9
Weight Limits .....	2-9
Center of Gravity Limits .....	2-9
Altitude Limits .....	2-9
Maneuver Limits .....	2-9
Flap Limitations .....	2-11
Flight Load Factor Limits .....	2-11
Fuel Limits .....	2-11
Maximum Occupancy .....	2-11
Minimum Flight Crew .....	2-11
Paint .....	2-11
Runway Surface .....	2-12
Smoking .....	2-12
System Limits .....	2-12
Cirrus Airframe Parachute System (CAPS) .....	2-12
Multi-Function Display .....	2-12
Oxygen System .....	2-12
Kinds of Operation .....	2-13
Icing .....	2-13
Kinds of Operation Equipment List .....	2-13
Placards .....	2-17

Intentionally Left Blank

## Introduction

• Note •

Limitations associated with optional equipment are not described in this section. For optional equipment limitations, *refer to Section 9, Supplements*

The limitations included in this Section of the Pilot's Operating Handbook (POH) are approved by the Federal Aviation Administration. This section provides operating limitations, instrument markings and basic placards required by regulation and necessary for the safe operation of the SR22 and its standard systems and equipment. *Refer to Section 9* of this handbook for amended operating limitations for airplanes equipped with optional equipment. Compliance with the operating limitations in this section and in Section 9 is required by Federal Aviation Regulations.

## Certification Status

The Cirrus SR22 is certificated under the requirements of Federal Aviation Regulations (FAR) Part 23 as documented by FAA Type Certificate TC A00009CH.

## Airspeed Limitations

The indicated airspeeds in the following table are based upon Section 5 Airspeed Calibrations using the normal static source. When using the alternate static source, allow for the airspeed calibration variations between the normal and alternate static sources.

Speed	KIAS	KCAS	Remarks
V <sub>NE</sub>	201	204	<b>Never Exceed Speed</b> is the speed limit that may not be exceeded at any time.
V <sub>NO</sub>	178	180	<b>Maximum Structural Cruising Speed</b> is the speed that should not be exceeded except in smooth air, and then only with caution.
V <sub>O</sub> 3400 Lb	133	135	<b>Operating Maneuvering Speed</b> is the maximum speed at which full control travel may be used. Below this speed the airplane stalls before limit loads are reached. Above this speed, full control movements can damage the airplane.
V <sub>FE</sub> 50% Flaps 100% Flaps	119 104	120 104	<b>Maximum Flap Extended Speed</b> is the highest speed permissible with wing flaps extended.
V <sub>PD</sub>	133	135	<b>Maximum Demonstrated Parachute Deployment Speed</b> is the maximum speed at which parachute deployment has been demonstrated.

**Figure 2-1**  
**Airspeed Limits**



## Airspeed Indicator Markings

The airspeed indicator markings are based upon Section 5 Airspeed Calibrations using the normal static source. When using the alternate static source, allow for the airspeed calibration variations between the normal and alternate static sources.

Marking	Value (KIAS)	Remarks
White Arc	59 - 104	Full Flap Operating Range. Lower limit is the most adverse stall speed in the landing configuration. Upper limit is the maximum speed permissible with flaps extended.
Green Arc	70 - 178	Normal Operating Range. Lower limit is the maximum weight stall at most forward C.G. with flaps retracted. Upper limit is the maximum structural cruising speed.
Yellow Arc	178 - 201	Caution Range. Operations must be conducted with caution and only in smooth air.
Red Line	201	Never exceed speed. Maximum speed for all operations.

**Figure 2-2**  
**Airspeed Indicator Markings**

## Power Plant Limitations

### Engine

Teledyne Continental ..... IO-550-N

Power Rating ..... 310 hp @ 2700 rpm

Maximum RPM ..... 2700 rpm

Oil:

Oil Temperature ..... 240° F (115° C) maximum

Oil Pressure:

Minimum ..... 10 psi

Maximum ..... 100 psi

Approved Oils:

*Engine Break-In:* For first 25 hours of operation or until oil consumption stabilizes use straight mineral oil conforming to MIL-L-6082. If engine oil must be added to the factory installed oil, add only MIL-L-6082 straight mineral oil.

*After Engine Break-In:* Use only oils conforming to Teledyne Continental Specification MHS-24 (Ashless Dispersant Lubrication Oil) or MHS-25 (Synthetic Lubrication Oil). Refer to Section 8 - Oil Servicing. Oil viscosity range as follows:

All Temperatures ..... 15W-50, 20W-50 or 20W-60

Below 40 °F (4° C) ..... SAE 30

Above 40 °F (4° C) ..... SAE 50

Fuel Grade ..... Aviation Grade 100 LL (Blue) or 100 (green)

• Note •

Refer to General Limitations – Fuel Limits in this section for operational limitations regarding fuel and fuel storage.

## Propeller

### *Hartzell*

Propeller Type ..... Constant Speed, Three Blade  
Model Number ..... PHC-J3YF-1RF/F7694  
Diameter ..... 78.0" (76.5" Minimum)  
Model Number ..... PHC-J3YF-1RF/F7693DF  
Diameter ..... 78.0" (76.5" Minimum)

*or*

### **McCauley**

Propeller Type ..... Constant Speed, Three Blade  
Model Number ..... D3A34C443/78CYA-0  
Diameter ..... 78.0" (76.5" Minimum)

# Instrument Markings

Instrument (Range)	Red Line	Green Arc	Yellow Arc	Red Line
	Minimum	Normal	Caution	Maximum

Power Plant Instruments				
Tachometer (0 - 3500 RPM)	—	500 - 2700	—	2700
Cylinder Head Temperature (200° F - 500° F)	—	240° - 420° F	420° - 460° F	460° F
Exhaust Gas Temp. (1250° - 1650° F)	—	—	—	—
Manifold Pressure (10 – 30 Inches Hg)	—	15 - 29.5 in. Hg	—	—
Fuel Flow (0 – 30 U.S. Gal./Hr.)	—	10 - 20 GPH	—	—
Oil Temperature (50° - 240° F)	—	100° - 240° F	—	240° F
Oil Pressure (0 - 100 PSI)	10 psi (Idle)	30 - 60 psi	10 - 30 psi 60 - 100 psi	100 psi (Cold)
Fuel Quantity (0 – 90 U.S. Gallon)	0 gal.	—	0 - 14 gal.	—

Miscellaneous Instruments				
Voltmeter (16 - 32 Volts)	—	24 - 30 Volts	—	32 Volts

**Figure 2-3**  
**Instrument Markings**

## General Limitations

### Weight Limits

Maximum Takeoff Weight ..... 3400 lb (1542 Kg)

Maximum Weight in Baggage Compartment..... 130 lb (59 Kg)

### Center of Gravity Limits

Reference Datum ..... 100 inches forward of firewall

Forward ..... *Refer to Figure 2-4*

Aft ..... *Refer to Figure 2-4*

### Altitude Limits

Maximum Takeoff Altitude ..... 10,000 Feet MSL

Maximum Operating Altitude ..... 17,500 Feet MSL

The operating rules (FAR Part 91 and FAR Part 135) require the use of supplemental oxygen at specified altitudes below the maximum operating altitude. *Refer to Oxygen System Limitations in this Section.*

### Maneuver Limits

Aerobatic maneuvers, including spins, are prohibited.

• Note •

Because the SR22 has not been certified for spin recovery, the Cirrus Airframe Parachute System (CAPS) must be deployed if the airplane departs controlled flight. *Refer to Section 3 – Emergency Procedures, Inadvertent Spiral/Spin Entry.*

This airplane is certified in the normal category and is not designed for aerobatic operations. Only those operations incidental to normal flight are approved. These operations include normal stalls, chandelles, lazy eights, and turns in which the angle of bank is limited to 60°.

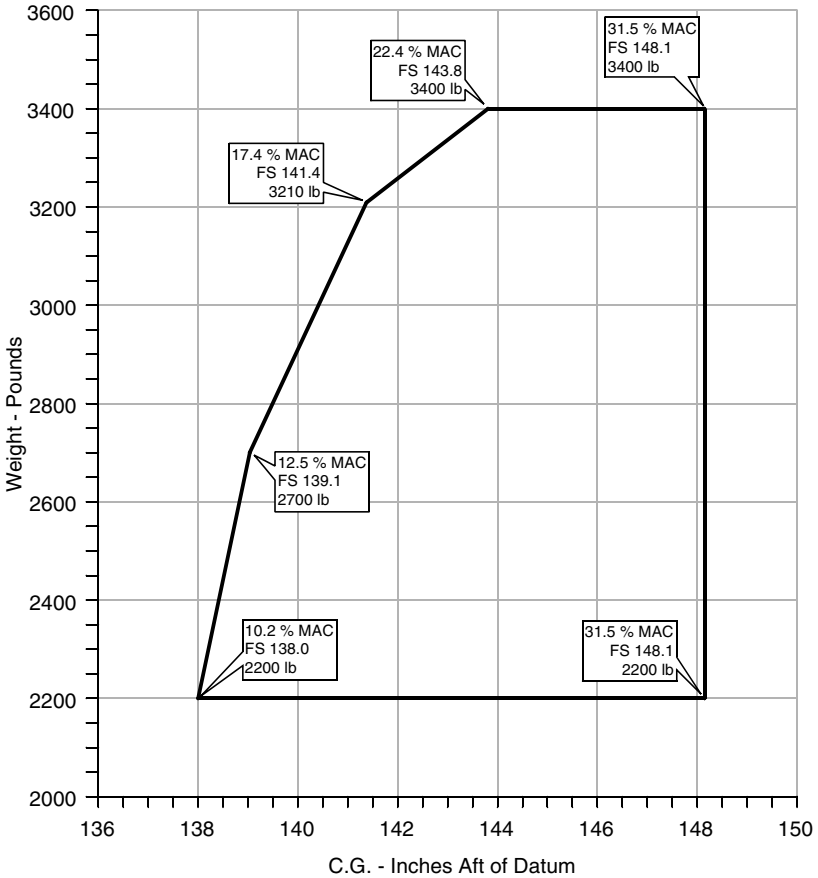

SR22\_FM02\_1944

**FORWARD LIMIT** - The forward limit is FS 138.0 (10.2% MAC) at 2200 lb, with straight line taper to FS 139.1 (12.5% MAC) at 2700 lb, to FS 141.4.0 (17.4% MAC) at 3210 lb, and to FS 143.8 (22.4% MAC) at 3400 lb.

**AFT LIMIT** - The aft limit is FS 148.1 (31.5% MAC) at all weights from 2200 lb to 3400 lb.

**Figure 2-4**  
**C.G. Envelope**

## Flap Limitations

*Serials 0002 through 0227 before accomplishment of Service Bulletin SB 22-27-02: Simultaneous Flap operation and COM transmission is prohibited.*

Approved Takeoff Settings..... UP (0%) or 50%  
Approved Landing Settings ..... Up (0%), 50%, or 100%

## Flight Load Factor Limits

Flaps UP (0%), 3400 lb. ....+3.8g, -1.9g  
Flaps 50% .....+1.9g, -0g  
Flaps 100% (Down), 3400 lb. ....+1.9g, -0g

## Fuel Limits

Approved Fuel ..... Aviation Grade 100 LL (Blue) or 100 (Green)  
Total Fuel Capacity..... 84.0 U.S. Gallon (318.0 L)  
Total Fuel Each Tank..... 42.0 U.S. Gallon (159.0 L)  
Total Usable Fuel (all flight conditions)..... 81.0 U.S. Gallon (306.6 L)  
Maximum Allowable Fuel Imbalance ..... 10.0 U.S. Gallon (¼ tank)

The fuel system BOOST pump must be on for takeoff, landing, and for switching fuel tanks.

## Maximum Occupancy

Occupancy of this airplane is limited to four persons (the pilot and three passengers).

## Minimum Flight Crew

The minimum flight crew is one pilot.

## Paint

To ensure that the temperature of the composite structure does not exceed 150° F (66° C), the outer surface of the airplane must be painted with an approved white paint, except for areas of registration marks, placards, and minor trim. *Refer to SR22 Airplane Maintenance Manual (AMM), Chapter 51, for specific paint requirements.*

## Runway Surface

This airplane may be operated into and off of any runway surface.

## Smoking

Smoking is prohibited in this airplane.

## System Limits

### Cirrus Airframe Parachute System (CAPS)

V<sub>PD</sub> Maximum Demonstrated Deployment Speed.....133 KIAS

- Note •

*Refer to Section 10 – Safety Information, for additional CAPS guidance.*

## Multi-Function Display

The Multi-Function Display is not approved as a primary navigation instrument. Information displayed on the multi-function display may be used for advisory purposes only.

## Oxygen System

Whenever the operating rules require the use of supplemental oxygen, the pilot must:

- Use an oxygen system approved by Cirrus Design and listed in the Oxygen System AFM Supplement Part Number 13772-109.
- Secure the oxygen bottle in the right front seat as described in the AFM Supplement noted above.



## Kinds of Operation

The SR22 is equipped and approved for the following type operations:

- VFR day and night.
- IFR day and night.

## Icing

Flight into known icing conditions is prohibited.

## Kinds of Operation Equipment List

The following listing summarizes the equipment required under Federal Aviation Regulations (FAR) Part 23 for airworthiness under the listed kind of operation. Those minimum items of equipment necessary under the operating rules are defined in FAR Part 91 and FAR Part 135 as applicable.

- Note •

All references to types of flight operations on the operating limitations placards are based upon equipment installed at the time of Airworthiness Certificate issuance.

System, Instrument, and/or Equipment	Kinds of Operation				Remarks, Notes, and/or Exceptions
	VFR Day	VFR Nt.	IFR Day	IFR Nt.	
<b>Communications</b>					
VHF COM	—	—	1	1	
<b>Electrical Power</b>					
Battery 1	1	1	1	1	
Battery 2	—	—	1	1	
Alternator 1	1	1	1	1	
Alternator 2	—	—	1	1	
Ammeter	1	1	1	1	
Low Volts Annunciator	1	1	1	1	

System, Instrument, and/or Equipment	Kinds of Operation				Remarks, Notes, and/or Exceptions
	VFR Day	VFR Nt.	IFR Day	IFR Nt.	
ALT 1 Annunciator	1	1	1	1	As Required.
ALT 2 Annunciator	1	1	1	1	
Circuit Breakers	A/R	A/R	A/R	A/R	
<b>Equipment &amp; Furnishings</b>					
Emergency Locator Transmitter	1	1	1	1	One Seat Belt for each occupant.
Restraint System	A/R	A/R	A/R	A/R	
<b>Fire Protection</b>					
Fire Extinguisher	1	1	1	1	
<b>Flight Controls</b>					
Flap Position Lights	3	3	3	3	
Flap System	1	1	1	1	
Pitch Trim Indicator	1	1	1	1	
Pitch Trim System	1	1	1	1	
Roll Trim Indicator	1	1	1	1	
Roll Trim System	1	1	1	1	
Rudder Trim and Indicator	1	1	1	1	Rudder Trim System and/or Indicator may be inoperative provided the trim tab is fixed in the streamlined position, the indicator is placarded "Rudder Trim Inop," and the system is electrically disabled

System, Instrument, and/or Equipment	Kinds of Operation				Remarks, Notes, and/or Exceptions
	VFR Day	VFR Nt.	IFR Day	IFR Nt.	
Stall Warning System	1	1	1	1	
<b>Fuel</b>					
Auxiliary Boost Pump	1	1	1	1	
Fuel Quantity Indicator	2	2	2	2	
Fuel Selector Valve	1	1	1	1	
<b>Ice &amp; Rain Protection</b>					
Alternate Engine Air Induction System	1	1	1	1	
Alternate Static Air Source	1	1	1	1	
Pitot Heater	—	—	1	1	
<b>Landing Gear</b>					
Wheel Pants	—	—	—	—	May be removed.
<b>Lights</b>					
Anticollision Lights	2	2	2	2	
Instrument Lights	—	❖	—	❖	❖-Must be operative.
Navigation Lights	—	2	—	2	
<b>Navigation &amp; Pitot Static</b>					
Altimeter	1	1	1	1	
Airspeed Indicator	1	1	1	1	
Vertical Speed Indicator	—	—	—	—	
Magnetic Compass	1	1	1	1	
Attitude Gyro	—	—	1	1	
HSI	—	—	1	1	

System, Instrument, and/or Equipment	Kinds of Operation				Remarks, Notes, and/or Exceptions
	VFR Day	VFR Nt.	IFR Day	IFR Nt.	
Turn Coordinator (Gyro)	—	—	1	1	
Clock	—	—	1	1	
Nav Radio	—	—	1	1	
Pitot System	1	1	1	1	
Static System, Normal	1	1	1	1	
Multi-Function Display	—	—	—	—	
<b>Engine Indicating</b>					
Cylinder Head Temperature Gage	—	—	—	—	
Exhaust Gas Temperature Gage	—	—	—	—	
Fuel Flow Gage	1	1	1	1	
Manifold Pressure Gage	1	1	1	1	
Oil Pressure Gage	1	1	1	1	
Oil Quantity Indicator (Dipstick)	1	1	1	1	
Oil Temperature Gage	1	1	1	1	
Tachometer	1	1	1	1	
<b>Special Equipment</b>					
Cirrus Airframe Parachute (CAPS)	1	1	1	1	
Airplane Flight Manual	1	1	1	1	Included w/ POH.

## Placards

*Engine compartment, inside oil filler access:*

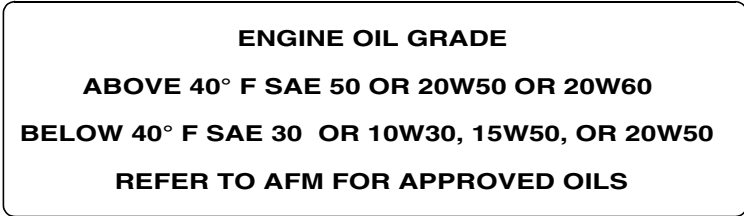

*Wing, adjacent to fuel filler caps:*

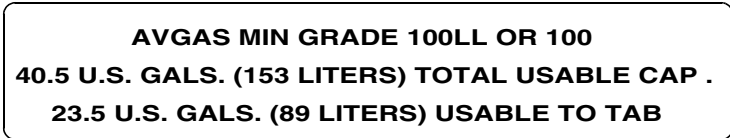

*Serials 0002 thru 0549.*

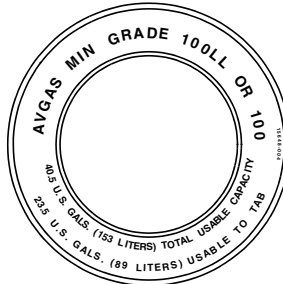

*Serials 0550 & subs.*

*Upper fuselage, either side of CAPS rocket cover:*



SR2\_FM02\_1372A

**Figure 2-5**  
**Placards (Sheet 1 of 7)**

*Elevator, Rudder, & Elec. Trim Tab (if installed), both sides:*



*Left fuselage, on external power supply door:*

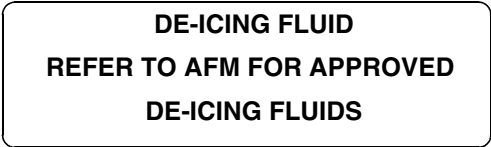
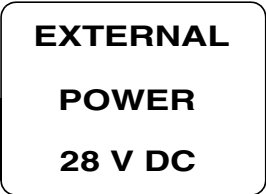

*Serials 0334 & subs w/ Ice Protection.*

*Doors, above and below latch:*

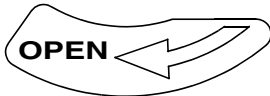
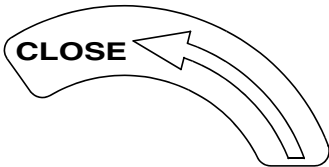

*Serials 0002 thru 0521.*

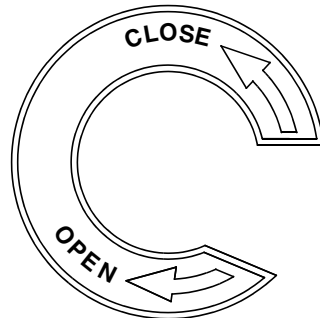

*Serials 0522 thru 0820.*

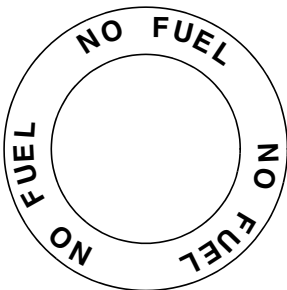

*Serials 0334 & subs w/ Ice Protection.*

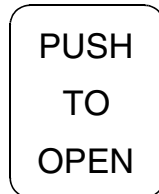

*Serials 0821 & subs.*

SR22\_FM02\_1373A

**Figure 2-5  
Placards (Sheet 2 of 7)**

Engine control panel:

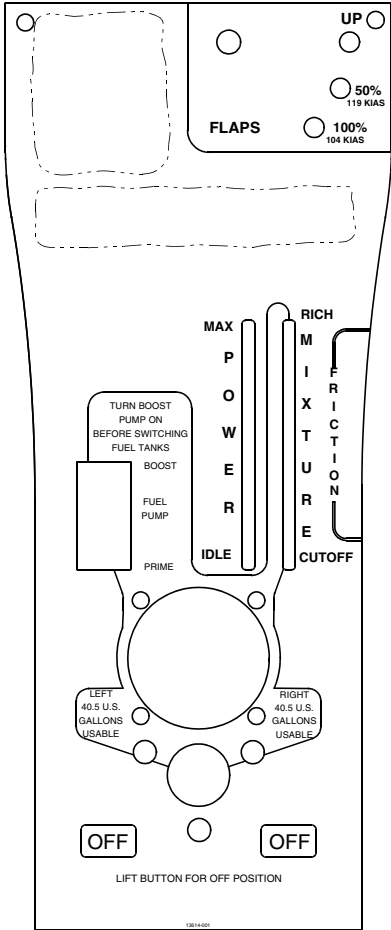

Serials 0002 & subs.

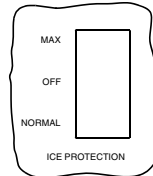

Serials 0334 thru 0434.

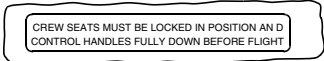

Serials 0410 & subs  
& serials 0002 thru 0409  
after incorporating SA 02-13.

SR22\_FM02\_1374C

Figure 2-5  
Placards (Sheet 3 of 7)

Wing, flap aft edge and fuselage vortex generator:

**NO STEP**

Cabin Door Window, lower edge, centered, applied upside down:

**RESCUE: FRACTURE AND REMOVE WINDOW**

Bolster Switch Panel, left edge:

**THIS AIRCRAFT IS CERTIFIED FOR THE  
FOLLOWING FLIGHT OPERATIONS:  
DAY - NIGHT - VFR - IFR  
(WITH REQUIRED EQUIPMENT)**

**FLIGHT INTO KNOWN ICING IS PROHIBITED**

**OPERATE PER AIRPLANE FLIGHT MANUAL**

Instrument Panel Upper left:

**MANEUVERING  
SPEED: V<sub>o</sub> 133 KIAS**

**NORMAL CATEGORY AIRPLANE**

**NO ACROBATIC MANEUVERS,  
INCLUDING SPINS, APPROVED**

Instrument Panel Upper Right:

**ALTITUDE GPH**

16000	—	17
12000	—	18
8000	—	21
4000	—	24
SL	—	27

**MAX POWER FUEL FLOWS**

SR22\_FM02\_1375C

**Figure 2-5  
Placards (Sheet 4 of 7)**



*Bolster Panel, both sides:*



*Serials 0656 & subs.*

*Baggage Compartment, aft edge:*

**ELT LOCATED BEHIND BULKHEAD  
REMOVE CARPET AND ACCESS PANEL**

*Baggage Compartment Door, inside:*

**DISTRIBUTED FLOOR LIMIT 130 LBS  
BAGGAGE STRAP CAPACITY IS 35 LBS EACH MAXIMUM  
SEE AIRPLANE FLIGHT MANUAL FOR BAGGAGE TIE-DOWN  
AND WEIGHT AND BALANCE INFORMATION**

12378-001 REV A

SR22\_FM02\_1376C

**Figure 2-5  
Placards (Sheet 5 of 7)**

*Instrument Panel:*

**NO SMOKING  
FASTEN SEATBELTS  
FIRE EXTINGUISHER  
UNDER PILOT SEAT FRONT**

**OR**

*Above MFD (on one line):*

**FASTEN SEATBELTS  
FIRE EXTINGUISHER UNDER PILOT SEAT FRONT  
NO SMOKING**

*Cabin Window, above door latch:*

**EMERGENCY EXIT  
REMOVE EGRESS HAMMER FROM ARMREST LID  
STRIKE CORNER OF WINDOW,  
KICK OR PUSH OUT AFTER FRACTURING**

*Serials 0002 thru 0168.*

*Cabin Window, above door latch:*

**EMERGENCY EXIT  
REMOVE EGRESS HAMMER FROM WITHIN  
CENTER ARMREST LID. STRIKE CORNER OF  
WINDOW. KICK OR PUSH OUT AFTER FRACTURING**

*Serials 0169 & subs.*

*SR22\_FM02\_1517C*

**Figure 2-5  
Placards (Sheet 6 of 7)**

CAPS Deployment Handle Cover, above pilot's right shoulder:

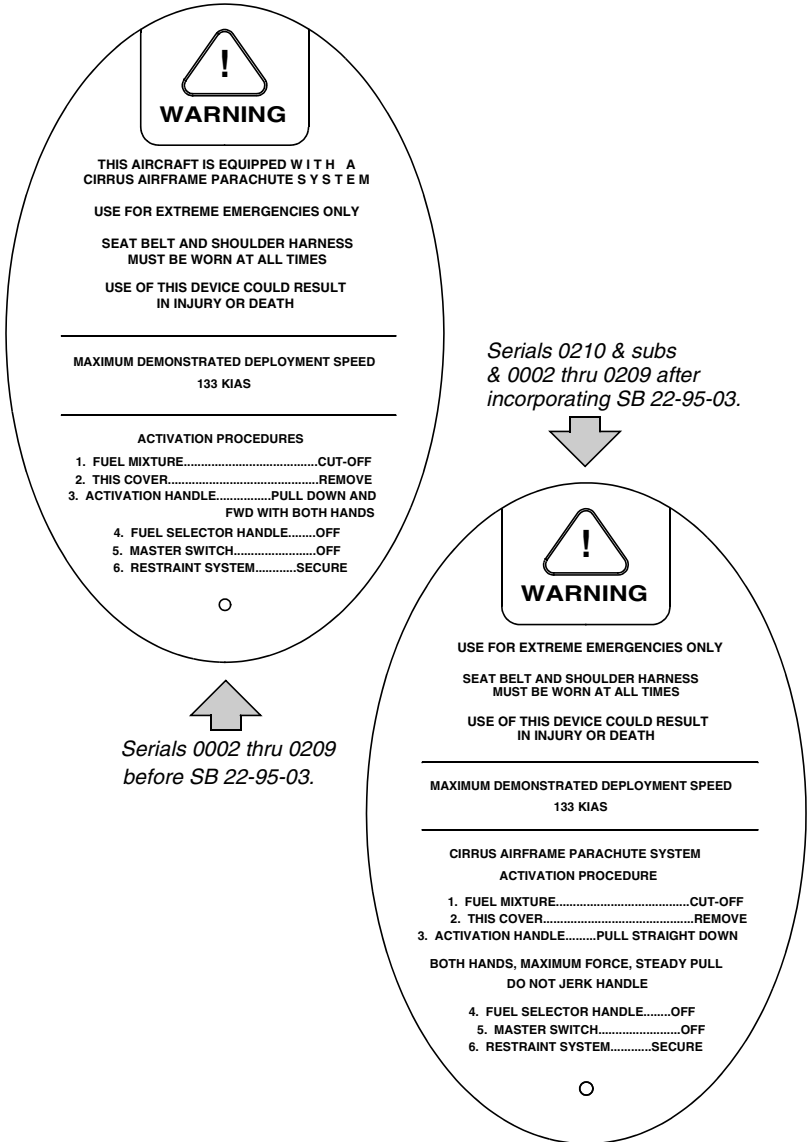

SR22\_FM02\_1437B

Figure 2-5  
Placards (Sheet 7 of 7)

Intentionally Left Blank

# **Section 3**

## **Emergency Procedures**

### **Table of Contents**

Introduction .....	3-3
Airspeeds for Emergency Operations .....	3-4
Emergency Procedures Guidance .....	3-5
Preflight Planning.....	3-5
Preflight Inspections/Maintenance .....	3-5
Methodology .....	3-5
Ground Emergencies .....	3-7
Engine Fire During Start .....	3-7
Brake Failure During Taxi .....	3-7
Aborted Takeoff .....	3-7
Emergency Engine Shutdown On Ground.....	3-8
Emergency Ground Egress .....	3-8
In-Flight Emergencies .....	3-9
Engine Failure On Takeoff (Low Altitude).....	3-9
Maximum Glide .....	3-10
Engine Failure In Flight.....	3-11
Engine Airstart .....	3-12
Engine Partial Power Loss.....	3-13
Low Oil Pressure .....	3-15
Propeller Governor Failure .....	3-15
Smoke and Fume Elimination.....	3-16
Engine Fire In Flight.....	3-16
Wing Fire In Flight.....	3-16
Cabin Fire In Flight .....	3-17
Inadvertent Icing Encounter.....	3-18
Emergency Descent .....	3-18
Inadvertent IMC Encounter.....	3-19
Inadvertent Spiral Dive During IMC Flight .....	3-19
Door Open In Flight .....	3-19
Spins .....	3-20
CAPS Deployment.....	3-21
Landing Emergencies .....	3-23
Forced Landing (Engine Out) .....	3-23

**Section 3**  
**Emergency Procedures**

**Cirrus Design**  
**SR22**

Landing Without Elevator Control .....	3-24
Landing With Failed Brakes .....	3-24
Landing With Flat Tire .....	3-25
System Malfunctions .....	3-27
Alternator Failure .....	3-27
LOW VOLTS Warning Light Illuminated .....	3-29
Communications Failure .....	3-29
Power Lever Linkage Failure .....	3-30
Pitot Static Malfunction .....	3-31
Electric Trim/Autopilot Failure .....	3-32

## Introduction

This section provides procedures for handling emergencies and abnormal situations that may occur while operating the SR22. Although emergencies caused by airplane, systems, or engine malfunctions are extremely rare, the guidelines described in this section should be considered and applied as necessary should an emergency arise.

• Note •

Emergency procedures associated with optional systems can be found in Section 9.

## Airspeeds for Emergency Operations

### Maneuvering Speed:

3400 lb ..... 133 KIAS

### Best Glide:

3400 lb ..... 88 KIAS

2900 lb ..... 87 KIAS

### Emergency Landing (Engine-out):

Flaps Up..... 90 KIAS

Flaps 50% ..... 85 KIAS

Flaps 100% ..... 80 KIAS



## Emergency Procedures Guidance

Although this section provides procedures for handling most emergencies and abnormal flight conditions that could arise in the SR22, it is not a substitute for thorough knowledge of the airplane and general aviation techniques. A thorough study of the information in this handbook while on the ground will help you prepare for time-critical situations in the air.

### Preflight Planning

Enroute emergencies caused by weather can be minimized or eliminated by careful flight planning and good judgment when unexpected weather is encountered.

### Preflight Inspections/Maintenance

In-flight mechanical problems in the SR22 will be extremely rare if proper preflight inspections and maintenance are practiced. Always perform a thorough walk-around preflight inspection before any flight to ensure that no damage occurred during the previous flight or while the airplane was on the ground. Pay special attention to any oil leaks or fuel stains that could indicate engine problems.

### Methodology

Aircraft emergencies are very dynamic events. Because of this, it is impossible to address every action a pilot might take to handle a situation. However, four basic actions can be applied to any emergency. They are:

***Maintain Aircraft Control*** — Many minor aircraft emergencies turn into major ones when the pilot fails to maintain aircraft control. Remember, do not panic and do not fixate on a particular problem. Over-attention to a faulty warning light during an instrument approach can lead to a pilot induced unusual attitude and possibly worse. To avoid this, even in an emergency: aviate, navigate, and communicate, in this order. Never let anything interfere with your control of the airplane. Never stop flying.

***Analyze the Situation*** — Once you are able to maintain control of the aircraft, assess the situation. Look at the engine instruments. Listen to the engine. Determine what the airplane is telling you.

***Take Appropriate Action*** — In most situations, the procedures listed in this section will either correct the aircraft problem or allow safe recovery of the aircraft. Follow them and use good pilot judgment.

***Land as soon as Conditions Permit*** — Once you have handled the emergency, assess your next move. Handle any non-critical “clean-up” items in the checklist and put the aircraft on the ground. Remember, even if the airplane appears to be in sound condition, it may not be.

## Ground Emergencies

### Engine Fire During Start

A fire during engine start may be caused by fuel igniting in the fuel induction system. If this occurs, attempt to draw the fire back into the engine by continuing to crank the engine.

1. Mixture ..... CUTOFF
2. Fuel Pump ..... OFF
3. Fuel Selector ..... OFF
4. Power Lever ..... FORWARD
5. Starter ..... CRANK
6. If flames persist, perform *Emergency Engine Shutdown on Ground* and *Emergency Ground Egress* checklists.

### Brake Failure During Taxi

Ground steering is accomplished by differential braking. However, increasing power may allow some rudder control due to increased groundspeed and airflow over the rudder.

1. Engine Power ..... AS REQUIRED
  - To stop airplane - REDUCE
  - If necessary for steering - INCREASE
2. Directional Control ..... MAINTAIN WITH RUDDER
3. Brake Pedal(s) ..... PUMP

### Aborted Takeoff

Use as much of the remaining runway as needed to safely bring the airplane to a stop or to slow the airplane sufficiently to turn off the runway.

1. Power Lever ..... IDLE
2. Brakes ..... AS REQUIRED

**• Caution •**

For maximum brake effectiveness, retract flaps, hold control yoke full back, and bring the airplane to a stop by smooth,

even application of the brakes to avoid loss of control and/or a blown tire.

## Emergency Engine Shutdown On Ground

1. Power Lever ..... IDLE
2. Fuel Pump (if used)..... OFF
3. Mixture ..... CUTOFF
4. Fuel Selector..... OFF
5. Ignition Switch..... OFF
6. Bat-Alt Master Switches..... OFF

## Emergency Ground Egress

### • WARNING •

While exiting the airplane, make sure evacuation path is clear of other aircraft, spinning propellers, and other hazards.

1. Engine ..... SHUTDOWN

#### • Note •

If the engine is left running, set the Parking Brake prior to evacuating the airplane.

2. Seat belts ..... RELEASE
3. Airplane ..... EXIT

#### • Note •

If the doors cannot be opened, break out the windows with egress hammer, located in the console between the front seats, and crawl through the opening.

## In-Flight Emergencies

### Engine Failure On Takeoff (Low Altitude)

If the engine fails immediately after becoming airborne, abort on the runway if possible. If altitude precludes a runway stop but is not sufficient to restart the engine, lower the nose to maintain airspeed and establish a glide attitude. In most cases, the landing should be made straight ahead, turning only to avoid obstructions. After establishing a glide for landing, perform as many of the checklist items as time permits.

#### • **WARNING** •

If a turn back to the runway is elected, be very careful not to stall the airplane.

1. Best Glide or Landing Speed (as appropriate) ..... ESTABLISH
2. Mixture .....CUTOFF
3. Fuel Selector..... OFF
4. Ignition Switch..... OFF
5. Flaps ..... AS REQUIRED  
*If time permits:*
6. Power Lever ..... IDLE
7. Fuel Pump ..... OFF
8. Bat-Alt Master Switches..... OFF
9. Seat Belts ..... ENSURE SECURED

# Maximum Glide

**Conditions**

Power  
Propeller  
Flaps  
Wind

OFF  
Windmilling  
0% (UP)  
Zero

**Example:**

Altitude 10,000 ft. AGL  
Airspeed Best Glide  

---

Glide Distance 15.8 NM

**Best Glide Speed**  
3400 lb 88 KIAS  
**Maximum Glide Ratio ~ 9.6 : 1**

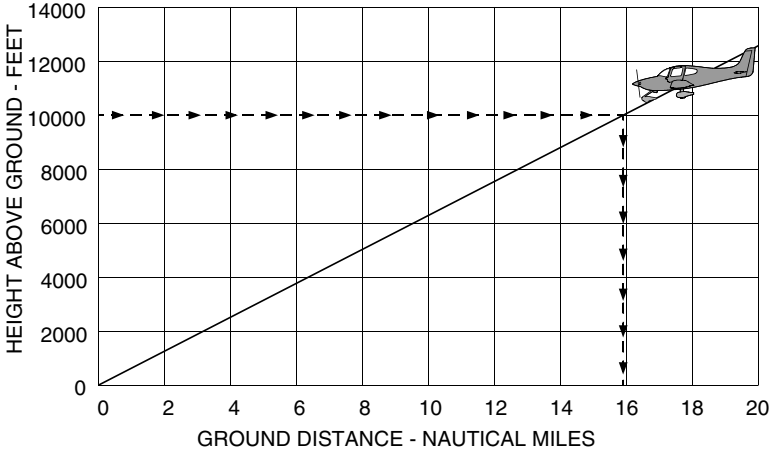

SR22\_FM03\_1391

**Figure 3-1**  
**Maximum Glide**

## Engine Failure In Flight

If the engine fails at altitude, pitch as necessary to establish best glide speed. While gliding toward a suitable landing area, attempt to identify the cause of the failure and correct it.

### • WARNING •

If engine failure is accompanied by fuel fumes in the cockpit, or if internal engine damage is suspected, move Mixture Control to CUTOFF and do not attempt a restart.

1. Best Glide Speed..... ESTABLISH

### • Note •

With a seized or failed engine, the distance that the airplane will glide will be more than the distance it would glide with the engine at idle, such as during training.

If the propeller is windmilling, some additional glide range may be achieved by moving the Power Lever to idle and increasing airspeed by 5 to 10 knots.

2. Mixture ..... FULL RICH
3. Fuel Selector..... SWITCH TANKS
4. Fuel Pump ..... BOOST
5. Alternate Induction Air .....ON
6. Ignition Switch.....CHECK, BOTH
7. If engine does not start, proceed to *Engine Airstart* or *Forced Landing* checklist, as required.

## Engine Airstart

The following procedures address the most common causes for engine loss. Switching tanks and turning the fuel pump on will enhance starting if fuel contamination was the cause of the failure. Leaning the mixture and then slowly enriching mixture may correct faulty mixture control.

• Note •

Engine airstarts may be performed during 1g flight anywhere within the normal operating envelope of the airplane.

1. Bat Master Switches ..... ON
2. Power Lever ..... 1/2" OPEN
3. Mixture ..... RICH
4. Fuel Selector ..... SWITCH TANKS
5. Ignition Switch ..... BOTH
6. Fuel Pump ..... BOOST
7. Alternate Induction Air ..... ON
8. Alt Master Switches ..... OFF
9. Starter (Propeller not Windmilling) ..... ENGAGE
10. Power Lever ..... slowly INCREASE
11. Alt Master Switches ..... ON
12. If engine will not start, perform *Forced Landing* checklist.



## Engine Partial Power Loss

Indications of a partial power loss include fluctuating RPM, reduced or fluctuating manifold pressure, low oil pressure, high oil temperature, and a rough-sounding or rough-running engine. Mild engine roughness in flight may be caused by one or more spark plugs becoming fouled. A sudden engine roughness or misfiring is usually evidence of a magneto malfunction.

• Note •

Low oil pressure may be indicative of an imminent engine failure – *Refer to Low Oil Pressure* procedure in this section for special procedures with low oil pressure.

• Note •

A damaged (out-of-balance) propeller may cause extremely rough operation. If an out-of-balance propeller is suspected, immediately shut down engine and perform Forced Landing checklist.

If a partial engine failure permits level flight, land at a suitable airfield as soon as conditions permit. If conditions do not permit safe level flight, use partial power as necessary to set up a forced landing pattern over a suitable landing field. Always, be prepared for a complete engine failure.

If the power loss is due to a fuel leak in the injector system, fuel sprayed over the engine may be cooled by the slipstream airflow which may prevent a fire at altitude. However, as the Power Lever is reduced during descent and approach to landing the cooling air may not be sufficient to prevent an engine fire.

• **WARNING** •

If there is a strong smell of fuel in the cockpit, divert to the nearest suitable landing field. Fly a forced landing pattern and shut down the engine fuel supply once a safe landing is assured.

The following procedure provides guidance to isolate and correct some of the conditions contributing to a rough running engine or a partial power loss: (*Continued on following page*)

1. Fuel Pump..... BOOST  
Selecting BOOST on may clear the problem if vapor in the injection lines is the problem or if the engine-driven fuel pump has partially failed. The electric fuel pump will not provide sufficient fuel pressure to supply the engine if the engine-driven fuel pump completely fails.
2. Fuel Selector..... SWITCH TANKS  
Selecting the opposite fuel tank may resolve the problem if fuel starvation or contamination in one tank was the problem.
3. Mixture ..... CHECK appropriate for flight conditions
4. Power Lever ..... SWEEP  
Sweep the Power Lever through range as required to obtain smooth operation and required power.
5. Alternate Induction Air..... ON  
A gradual loss of manifold pressure and eventual engine roughness may result from the formation of intake ice. Opening the alternate engine air will provide air for engine operation if the normal source is blocked or the air filter is iced over.
6. Ignition Switch..... BOTH, L, then R  
Cycling the ignition switch momentarily from BOTH to L and then to R may help identify the problem. An obvious power loss in single ignition operation indicates magneto or spark plug trouble. Lean the mixture to the recommended cruise setting. If engine does not smooth out in several minutes, try a richer mixture setting. Return ignition switch to the BOTH position unless extreme roughness dictates the use of a single magneto.
7. Land as soon as practical.

## Low Oil Pressure

If low oil pressure is accompanied by a rise in oil temperature, the engine has probably lost a significant amount of its oil and engine failure may be imminent. Immediately reduce engine power to idle and select a suitable forced landing field.

### • WARNING •

Prolonged use of high power settings after loss of oil pressure will lead to engine mechanical damage and total engine failure, which could be catastrophic.

### • Note •

Full power should only be used following a loss of oil pressure when operating close to the ground and only for the time necessary to climb to an altitude permitting a safe landing or analysis of the low oil pressure indication to confirm oil pressure has actually been lost.

If low oil pressure is accompanied by normal oil temperature, it is possible that the oil pressure sensor, gage, or relief valve is malfunctioning. In any case, land as soon as practical and determine cause.

1. Power Lever ..... MINIMUM REQUIRED
2. Land as soon as possible.

## Propeller Governor Failure

If the RPM does not respond to power lever movement or overspeeds, the most likely cause is a faulty governor or an oil system malfunction. If moving the power lever is difficult or rough, suspect a power lever linkage failure and perform the *Power Lever Linkage Failure* checklist.

### ***Propeller RPM will not increase:***

1. Oil Pressure ..... CHECK
2. Land as soon as practical.

### ***Propeller overspeeds or will not decrease:***

1. Power Lever ..... ADJUST (to keep RPM in limits)
2. Airspeed.....REDUCE to 90 KIAS
3. Land as soon as practical.

## Smoke and Fume Elimination

If smoke and/or fumes are detected in the cabin, check the engine instruments for any sign of malfunction. If a fuel leak has occurred, actuation of electrical components may cause a fire. If there is a strong smell of fuel in the cockpit, divert to the nearest suitable landing field. Perform a *Forced Landing* pattern and shut down the fuel supply to the engine once a safe landing is assured.

1. Heater ..... OFF
2. Air Vents..... OPEN, FULL COLD
3. Prepare to land as soon as possible.

*If airflow is not sufficient to clear smoke or fumes from cabin:*

4. Cabin Doors ..... UNLATCH

## Engine Fire In Flight

If an engine fire occurs during flight, do not attempt to restart the engine.

1. Mixture ..... CUTOFF
2. Fuel Pump..... OFF
3. Power Lever ..... IDLE
4. Fuel Selector ..... OFF
5. Ignition Switch ..... OFF
6. Perform *Forced Landing* checklist.

## Wing Fire In Flight

1. Pitot Heat Switch..... OFF
2. Navigation Light Switch..... OFF
3. Strobe Light Switch ..... OFF
4. If possible, side slip to keep flames away from fuel tank and cabin.

• Note •

Putting the airplane into a dive may blow out the fire. Do not exceed  $V_{NE}$  during the dive.

5. Land as soon as possible.

## Cabin Fire In Flight

If the cause of the fire is readily apparent and accessible, use the fire extinguisher to extinguish flames and land as soon as possible. Opening the vents may feed the fire, but to avoid incapacitating the crew from smoke inhalation, it may be necessary to rid cabin of smoke or fire extinguishant. If the cause of fire is not readily apparent, is electrical, or is not readily accessible, proceed as follows:

**• WARNING •**

*Serials 0435 and subsequent with PFD:* If the airplane is in IMC conditions, turn ALT 1, ALT 2, and BAT 1 switches OFF. Power from battery 2 will keep the Primary Flight Display operational for approximately 30 minutes.

1. Bat-Alt Master Switches..... OFF, AS REQ'D

**• Note •**

With Bat-Alt Master Switches OFF, engine will continue to run. However, no electrical power will be available.

2. Heater ..... OFF
3. Air Vents..... CLOSED
4. Fire Extinguisher..... ACTIVATE

**• WARNING •**

Halon gas used in the fire extinguisher can be toxic, especially in a closed area. After extinguishing fire, ventilate cabin by opening air vents and unlatching door (if required).

5. When fire extinguished, Air Vents ..... OPEN, FULL COLD
6. Avionics Power Switch ..... OFF
7. All other switches ..... OFF
8. Land as soon as possible.

*If setting master switches off eliminated source of fire or fumes and airplane is in night, weather, or IFR conditions:*

*(Continued on following page)*

**• WARNING •**

If airplane is in day VFR conditions and turning off the master switches eliminated the fire situation, leave the master switches OFF. Do not attempt to isolate the source of the fire by checking each individual electrical component.

- 9. Bat-Alt Master Switches ..... ON
- 10. Avionics Power Switch ..... ON
- 11. Activate required systems one at a time. Pause several seconds between activating each system to isolate malfunctioning system. Continue flight to earliest possible landing with malfunctioning system off. Activate only the minimum amount of equipment necessary to complete a safe landing.

**Inadvertent Icing Encounter**

Flight into known icing conditions is prohibited. However, If icing is inadvertently encountered:

- 1. Pitot Heat ..... ON
- 2. Exit icing conditions. Turn back or change altitude.
- 3. Cabin Heat ..... MAXIMUM
- 4. Windshield Defrost ..... FULL OPEN
- 5. Alternate Induction Air ..... ON

**Emergency Descent**

- 1. Power Lever ..... IDLE
- 2. Mixture ..... As Required

**• Caution •**

If significant turbulence is expected do not descend at indicated airspeeds greater than  $V_{NO}$  (178 KIAS)

- 3. Airspeed .....  $V_{NE}$  (201 KIAS)

## Inadvertent IMC Encounter

Upon entering IMC, a pilot who is not completely proficient in instrument flying should rely upon the autopilot to execute a 180° turn to exit the conditions. Immediate action should be made to turn back as follows:

1. Airplane Control ..... Establish Straight and Level Flight
2. Autopilot ..... Engage to hold Heading and Altitude
3. Heading ..... Reset to initiate 180° turn

## Inadvertent Spiral Dive During IMC Flight

1. Power Lever ..... IDLE
2. Stop the spiral dive by using coordinated aileron and rudder control while referring to the attitude indicator and turn coordinator to level the wings.
3. Cautiously apply elevator back pressure to bring airplane to level flight attitude.
4. Trim for level flight.
5. Set power as required.
6. Use autopilot if functional otherwise keep hands off control yoke, use rudder to hold constant heading.
7. Exit IMC conditions as soon as possible.

## Door Open In Flight

The doors on the SR22 will remain 1-3 inches open in flight if not latched. If this is discovered on takeoff roll, abort takeoff if practical. If already airborne:

1. Airspeed..... REDUCE TO 80 – 90 KIAS
2. Land as soon as practical.

## Spins

The SR22 is not approved for spins, and has not been tested or certified for spin recovery characteristics. The only approved and demonstrated method of spin recovery is activation of the Cirrus Airframe Parachute System (See *CAPS Deployment*, this section). Because of this, if the aircraft “departs controlled flight,” the CAPS must be deployed.

While the stall characteristics of the SR22 make accidental entry into a spin extremely unlikely, it is possible. Spin entry can be avoided by using good airmanship: coordinated use of controls in turns, proper airspeed control following the recommendations of this Handbook, and never abusing the flight controls with accelerated inputs when close to the stall (see *Stalls*, Section 4).

If, at the stall, the controls are misapplied and abused accelerated inputs are made to the elevator, rudder and/or ailerons, an abrupt wing drop may be felt and a spiral or spin may be entered. In some cases it may be difficult to determine if the aircraft has entered a spiral or the beginning of a spin.

### • WARNING •

In all cases, if the aircraft enters an unusual attitude from which recovery is not expected before ground impact, **immediate** deployment of the CAPS is required.

The minimum demonstrated altitude loss for a CAPS deployment from a one-turn spin is 920 feet. Activation at higher altitudes provides enhanced safety margins for parachute recoveries. Do not waste time and altitude trying to recover from a spiral/spin before activating CAPS.

### ***Inadvertent Spin Entry***

1. CAPS ..... Activate



## CAPS Deployment

The Cirrus Airframe Parachute System (CAPS) should be activated in the event of a life-threatening emergency where CAPS deployment is determined to be safer than continued flight and landing.

### • WARNING •

CAPS deployment is expected to result in loss of the airframe and, depending upon adverse external factors such as high deployment speed, low altitude, rough terrain or high wind conditions, may result in severe injury or death to the occupants. Because of this, CAPS should only be activated when any other means of handling the emergency would not protect the occupants from serious injury.

### • Caution •

Expected impact in a fully stabilized deployment is equivalent to a drop from approximately 13 feet.

### • Note •

Several possible scenarios in which the activation of the CAPS would be appropriate are discussed in Section 10 - Safety Information, of this Handbook. These include:

- Mid-air collision
- Structural failure
- Loss of control
- Landing in inhospitable terrain
- Pilot incapacitation

All pilots should carefully review the information on CAPS activation and deployment in Section 10 before operating the airplane.

Once the decision is made to deploy CAPS, the following actions should be taken:

1. Airspeed..... MINIMUM POSSIBLE

*(Continued on following page)*

The maximum demonstrated deployment speed is 133 KIAS. Reducing airspeed allows minimum parachute loads and prevents structural overload and possible parachute failure.

2. Mixture (If time and altitude permit) ..... CUTOFF

Generally, a distressed airplane will be safer for its occupants if the engine is not running.

3. Activation Handle Cover..... REMOVE

The cover has a handle located at the forward edge. Pull cover down to expose activation T-handle.

4. Activation Handle (Both Hands) ..... PULL STRAIGHT DOWN

Pull the activation T-handle from its holder. Clasp both hands around the handle and pull straight down in a strong, steady, and continuous motion. Maintain maximum pull force until the rocket activates. Pull forces up to, or exceeding, 45 pounds may be required. Bending of the handle-housing mount is to be expected.

**• WARNING •**

Jerking or rapidly pulling the activation T-handle will greatly increase the pull forces required to activate the rocket. Use a firm and steady pulling motion – a “chin-up” type pull enhances successful activation.

*After Deployment:*

5. Mixture ..... CHECK, CUTOFF

6. Fuel Selector ..... OFF

Shutting off fuel supply to engine will reduce the chances of fire resulting from impact at touchdown.

7. Bat-Alt Master Switches ..... OFF

8. Ignition Switch ..... OFF

9. Fuel Pump ..... OFF

10. ELT ..... ON

11. Seat Belts and Harnesses ..... TIGHTEN

All occupants must have seat belts and shoulder harness securely fastened.

12. Loose Items ..... SECURE

If time permits, all loose items should be secured to prevent injury from flying objects in the cabin at touchdown.

13. Assume emergency landing body position.

The emergency landing body position is assumed by crossing the arms across the chest, firmly grasping the shoulder harness, and holding the upper torso erect.

14. After the airplane comes to a complete stop, evacuate quickly and move upwind.

As occupants exit the airplane, the reduced weight may allow winds to drag the airplane further. As a result of landing impact, the doors may jam. If the doors cannot be opened, break out the windows with the egress hammer, located in the console between the front seats, and crawl through the opening.

## Landing Emergencies

### **Forced Landing (Engine Out)**

If all attempts to restart the engine fail and a forced landing is imminent, select a suitable field and prepare for the landing.

A suitable field should be chosen as early as possible so that maximum time will be available to plan and execute the forced landing. For forced landings on unprepared surfaces, use full flaps if possible. Land on the main gear and hold the nose wheel off the ground as long as possible.

If engine power is available, before attempting an “off airport” landing, fly over the landing area at a low but safe altitude to inspect the terrain for obstructions and surface conditions.

• Note •

Use of full (100%) flaps will reduce glide distance. Full flaps should not be selected until landing is assured.

If ditching, avoid a landing flare because of difficulty in judging height over water.

1. Best Glide Speed ..... ESTABLISH

*(Continued on following page)*

2. Radio..... Transmit (121.5 MHz) MAYDAY  
giving location and intentions
3. Transponder ..... SQUAWK 7700
4. If off airport, ELT ..... ACTIVATE
5. Power Lever ..... IDLE
6. Mixture ..... CUTOFF
7. Fuel Selector.....OFF
8. Ignition Switch.....OFF
9. Fuel Pump.....OFF
10. Flaps (when landing is assured) ..... 100%
11. Master Switches.....OFF
12. Seat Belt(s) ..... SECURED

### **Landing Without Elevator Control**

The pitch trim spring cartridge is attached directly to the elevator and provides a backup should you lose the primary elevator control system. Set elevator trim for a 80 KIAS approach to landing. Thereafter, do not change the trim setting until in the landing flare. During the flare, the nose-down moment resulting from a power reduction may cause the airplane to hit on the nosewheel. To avoid this, move the trim button to the full nose-up position during the flare and adjust the power for a smooth landing. At touchdown, bring the power lever to idle.

1. Flaps .....SET 50%
2. Trim .....SET 80 KIAS
3. Power .....AS REQUIRED FOR GLIDE ANGLE

### **Landing With Failed Brakes**

#### ***One brake inoperative***

1. Land on the side of runway corresponding to the inoperative brake.
2. Maintain directional control using rudder and working brake.

### ***Both brakes inoperative***

1. Divert to the longest, widest runway with the most direct headwind.
2. Land on downwind side of the runway.
3. Use the rudder for obstacle avoidance.

• Note •

Rudder effectiveness will decrease with decreasing airspeed.

4. Perform *Emergency Engine Shutdown on Ground* checklist.

### **Landing With Flat Tire**

If a flat tire or tread separation occurs during takeoff and you cannot abort, land as soon as conditions permit.

#### ***Main Gear***

1. Land on the side of the runway corresponding to the good tire.
2. Maintain directional control with the brakes and rudder.
3. Do not taxi. Stop the airplane and perform a normal engine shutdown.

#### ***Nose Gear***

1. Land in the center of the runway.
2. Hold the nosewheel off the ground as long as possible.
3. Do not taxi. Stop the airplane and perform a normal engine shutdown.

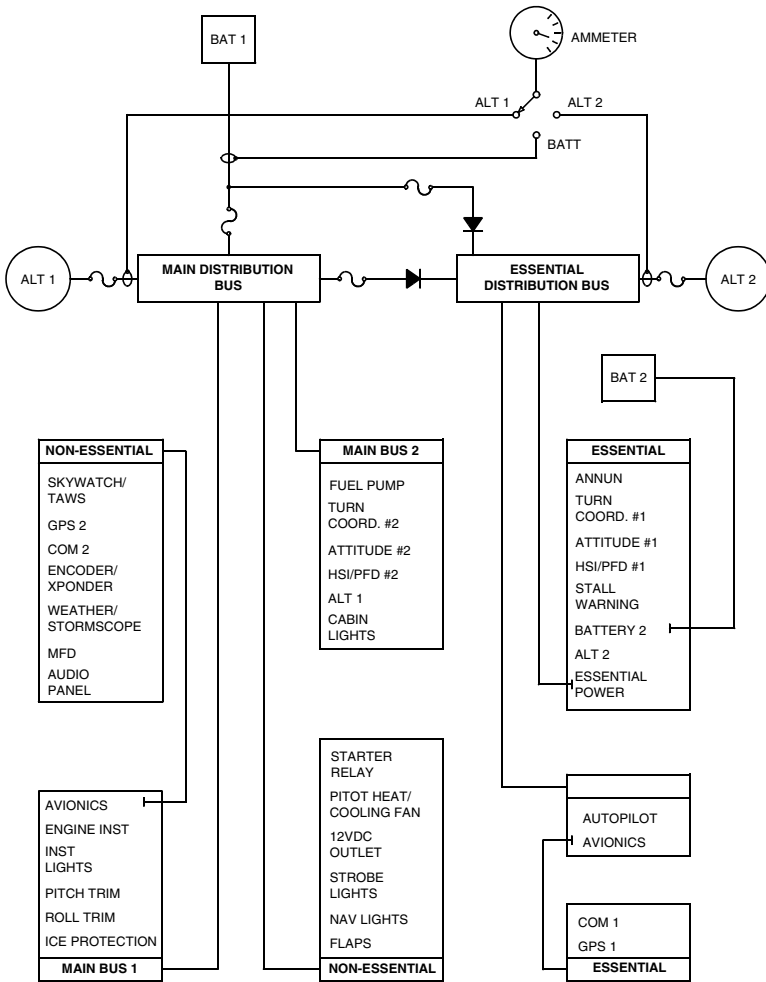

SR22\_FM03\_1453B

**Figure 3-2**  
**Electrical Power Distribution (Simplified)**

P/N 13772-001  
Revision A3

## System Malfunctions

### Alternator Failure

Steady illumination of either ALT caution light in the annunciator panel indicates a failure of the corresponding alternator. The most likely cause of the alternator failure is a wiring fault, a malfunctioning alternator, or a malfunctioning control unit. Usually, electrical power malfunctions are accompanied by an excessive rate of charge or a discharge rate shown on the ammeter.

#### • Caution •

Alternators in this airplane are self-exciting. These alternators require battery power for alternator starting; however, once started, the alternators will provide self-generated field power to continue operation in case of a battery failure. To assure alternator restart power is available if the alternators fail, the batteries should not be turned off during flight.

A flashing ALT 1 light indicates an excessive charging rate. This could occur with a very low BAT 1 and heavy equipment loads. Since the loads on ALT 2 are much lower, it is unlikely that a flashing ALT 2 light could occur, even with a very low BAT 2.

Figure 3-2 shows the electrical system power distribution. Individual loads on each circuit breaker panel bus are shown in the same order as they are on the panel. Note that items on the circuit breaker panel Essential buses are powered from ALT 1, ALT 2, BAT 1, and BAT 2. The circuit breaker panel Main buses and Non-Essential buses are powered from ALT 1 and BAT 1 only.

#### • Note •

If it is necessary to reduce electrical loads due to an alternator malfunction, switch off electrical components and/or systems that are not essential for the current flight conditions rather than pulling circuit breakers. Load shedding in this manner will prevent accidental circuit breaker disconnection and loss of power to flight-critical systems. See Figure 3-2, Electrical Power Distribution, for details on electrical busses and what components/systems they power.

**ALT 1 Light Steady**

Steady illumination indicates a failure of ALT 1. Attempt to bring alternator back on line. If alternator cannot be brought back, reduce loads and use Main Bus or Non-Essential loads only as necessary for flight conditions.

1. ALT 1 Master Switch .....OFF
2. Alternator 1 Circuit Breaker..... CHECK and RESET
3. ALT 1 Master Switch ..... ON

*If alternator does not reset:*

4. Switch off unnecessary equipment on Main Bus 1, Main Bus 2, and the Non-Essential Buses to reduce loads. Monitor voltage.
5. ALT 1 Master Switch .....OFF
6. Land as soon as practical.

**ALT 1 Light Flashing**

The most likely cause is a severely discharged battery along with heavy equipment loads. In this event, reduce loads on Main and Non-Essential buses and monitor amperage until charging rate is within normal limits. Then loads can be added as required.

1. Ammeter Switch ..... BATT
2. If charging rate is greater than 30 amps, reduce load on Main Bus 1, Main Bus 2, and Non-Essential buses.
3. Monitor ammeter until battery charge rate is less than 15 amps.
4. When battery charge rate is within limits, add loads as necessary for flight conditions.

**ALT 2 Light Steady**

Except during low RPM operations, steady illumination indicates a failure of ALT 2. If alternator cannot be brought back, Essential bus loads will be powered from ALT 1, BAT 1, and BAT 2.

• Note •

ALT 2 light will illuminate steady and ALT 2 will not come on line until 1700 - 2200 RPM.

1. ALT 2 Master Switch .....OFF



2. Alternator 2 Circuit Breaker ..... CHECK and RESET
3. ALT 2 Master Switch .....ON

*If alternator does not reset:*

4. Switch off unnecessary equipment on Main Bus 1, Main Bus 2, and Non-Essential Buses to reduce loads.
5. ALT 2 Master Switch ..... OFF
6. Land as soon as practical.

### **LOW VOLTS Warning Light Illuminated**

Illumination of the LOW VOLTS light indicates that the voltage measured at the Essential Bus is 24.5 volts or less. Typically, this indicates that the airplane is operating on battery power only and both alternators have failed or are off. If both alternators have failed:

1. Land as soon as practical.

### **Communications Failure**

Communications failure can occur for a variety of reasons. If, after following the checklist procedure, communication is not restored, proceed with FAR/AIM lost communications procedures.

• Note •

In the event of an audio panel power failure the audio panel connects COM 1 to the pilot's headset and speakers. Setting the audio panel 'Off' will also connect COM 1 to the pilot's headsets and speakers.

1. Switches, Controls ..... CHECK
2. Frequency .....CHANGE
3. Circuit Breakers ..... CHECK
4. Headset .....CHANGE
5. Hand Held Microphone ..... CONNECT

## Power Lever Linkage Failure

If the Power Lever linkage fails in flight, the engine will not respond to power lever control movements. Use power available and flaps as required to safely land the airplane.

If the power lever is stuck at or near the full power position, proceed to a suitable airfield. Fly a forced landing pattern. With landing assured, shut down engine by moving mixture control full aft to CUTOFF. If power is needed again, return mixture control to full RICH and regain safe pattern parameters or go-around. If airspeed cannot be controlled, shut engine down and perform the *Forced Landing* checklist. After landing, bring the airplane to a stop and complete the *Emergency Engine Shutdown on Ground* checklist.

If the power lever is stuck at or near the idle position and straight and level flight cannot be maintained, establish glide to a suitable landing surface. Fly a forced landing pattern.

1. Power Lever Movement..... VERIFY
2. Power ..... SET if able
3. Flaps ..... SET if needed
4. Mixture ..... AS REQUIRED (full rich to cut-off)
5. Land as soon as possible.

## Pitot Static Malfunction

### **Static Source Blocked**

If erroneous readings of the static source instruments (airspeed, altimeter and vertical speed) are suspected, the alternate static source valve, on side of console near pilot’s right ankle, should be opened to supply static pressure from the cabin to these instruments.

• Note •

If selecting the alternate static source does not work, in an emergency, cabin pressure can be supplied to the static pressure instruments by breaking the glass in the face of the vertical speed indicator. When static pressure is supplied through the vertical speed indicator, the vertical speed UP-DOWN indications will be reversed (i.e., the needle will indicate UP for descent and DOWN for climb).

With the alternate static source on, adjust indicated airspeed slightly during climb or approach according to the Airspeed Calibration (Alternate Static Source) table in Section 5 as appropriate for vent/heater configuration.

1. Pitot Heat .....ON
2. Alternate Static Source ..... OPEN

### **Pitot Tube Blocked**

If only the airspeed indicator is providing erroneous information, and in icing conditions, the most probable cause is pitot ice. If setting Pitot Heat ON does not correct the problem, descend to warmer air. If an approach must be made with a blocked Pitot tube, use known pitch and power settings and the GPS groundspeed indicator, taking surface winds into account.

1. Pitot Heat .....ON

## Electric Trim/Autopilot Failure

Any failure or malfunction of the electric trim or autopilot can be overridden by use of the control yoke. If runaway trim is the problem, de-energize the circuit by pulling the circuit breaker (PITCH TRIM, ROLL TRIM, or AUTOPILOT) and land as soon as conditions permit.

1. Airplane Control ..... MAINTAIN MANUALLY
2. Autopilot (if engaged) ..... Disengage

*If Problem Is Not Corrected:*

3. Circuit Breakers..... PULL AS Required
  - PITCH TRIM
  - ROLL TRIM
  - AUTOPILOT
4. Power Lever ..... AS REQUIRED
5. Control Yoke ..... MANUALLY HOLD PRESSURE
6. Land as soon as practical.

# **Section 4**

## **Normal Procedures**

### **Table of Contents**

Introduction .....	4-3
Airspeeds for Normal Operation .....	4-4
Normal Procedures .....	4-5
Preflight Inspection .....	4-5
Preflight Walk-Around .....	4-6
Before Starting Engine .....	4-9
Starting Engine .....	4-10
Before Taxiing .....	4-12
Taxiing .....	4-12
Before Takeoff .....	4-12
Maximum Power Fuel Flow .....	4-14
Takeoff .....	4-15
Normal Takeoff .....	4-15
Short Field Takeoff .....	4-16
Climb .....	4-16
Cruise .....	4-17
Cruise Leaning .....	4-18
Descent .....	4-18
Before Landing .....	4-18
Landing .....	4-19
Balked Landing/Go-Around .....	4-20
After Landing .....	4-20
Shutdown .....	4-21
Stalls .....	4-22
Environmental Considerations .....	4-23
Cold Weather Operation .....	4-23
Hot Weather Operation .....	4-26
Noise Characteristics/Abatement .....	4-26
Fuel Conservation .....	4-27

Intentionally Left Blank

## Introduction

This section provides amplified procedures for normal operation. Normal procedures associated with optional systems can be found in Section 9.

## Airspeeds for Normal Operation

Unless otherwise noted, the following speeds are based on a maximum weight of 3400 lb. and may be used for any lesser weight. However, to achieve the performance specified in Section 5 for takeoff and landing distance, the speed appropriate to the particular weight must be used.

### Takeoff Rotation:

- Normal, Flaps 50% ..... 70 KIAS
- Obstacle Clearance, Flaps 50% ..... 78 KIAS

### Enroute Climb, Flaps Up:

- Normal ..... 110-120 KIAS
- Best Rate of Climb, SL ..... 101 KIAS
- Best Rate of Climb, 10,000 ..... 95 KIAS
- Best Angle of Climb, SL ..... 78 KIAS
- Best Angle of Climb, 10,000 ..... 82 KIAS

### Landing Approach:

- Normal Approach, Flaps Up ..... 90-95 KIAS
- Normal Approach, Flaps 50% ..... 85-90 KIAS
- Normal Approach, Flaps 100% ..... 80-85 KIAS
- Short Field, Flaps 100% ( $V_{REF}$ ) ..... 77 KIAS

### Go-Around, Flaps 50%:

- Full Power ..... 80 KIAS

### Maximum Recommended Turbulent Air Penetration:

- 3400 lb ..... 133 KIAS
- 2900 lb ..... 123 KIAS

### Maximum Demonstrated Crosswind Velocity:

- Takeoff or Landing ..... 20 Knots



## Normal Procedures

### Preflight Inspection

Before carrying out preflight inspections, ensure that all required maintenance has been accomplished. Review your flight plan and compute weight and balance.

• Note •

Throughout the walk-around: check all hinges, hinge pins, and bolts for security; check skin for damage, condition, and evidence of delamination; check all control surfaces for proper movement and excessive free play; check area around liquid reservoirs and lines for evidence of leaking.

In cold weather, remove all frost, ice, or snow from fuselage, wing, stabilizers and control surfaces. Ensure that control surfaces are free of internal ice or debris. Check that wheel fairings are free of snow and ice accumulation. Check that pitot probe warms within 30 seconds of setting Pitot Heat to ON.

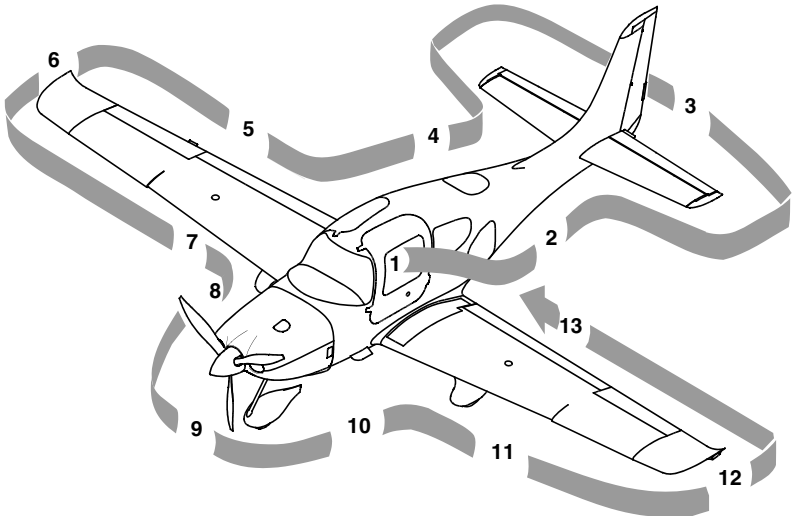

SR22\_FM04\_1454

**Figure 4-1**  
**Walk-Around**

## Preflight Walk-Around

1. Cabin
  - a. Required Documents ..... On Board
  - b. Avionics Power Switch ..... OFF
  - c. Bat 2 Master Switch ..... ON
  - d. Avionics Cooling Fan ..... Audible
  - e. Voltmeter ..... 23-25 Volts
  - f. Flap Position Light ..... OUT
  - g. Bat 1 Master Switch ..... ON
  - h. Fuel Quantity ..... Check
  - i. Fuel Selector ..... Select Fullest Tank
  - j. Flaps ..... 100%, Check Light ON
  - k. Oil Annunciator ..... On
  - l. Lights ..... Check Operation
  - m. Bat 1 and 2 Master Switches ..... OFF
  - n. Alternate Static Source ..... NORMAL
  - o. Circuit Breakers ..... IN
  - p. Fire Extinguisher ..... Charged and Available
  - q. Emergency Egress Hammer ..... Available
  - r. CAPS Handle ..... Pin Removed
2. Left Fuselage
  - a. COM 1 Antenna (top) ..... Condition and Attachment
  - b. Wing/Fuselage Fairing ..... Check
  - c. COM 2 Antenna (underside) ..... Condition and Attachment
  - d. Baggage Door ..... Closed and Secure
  - e. Static Button ..... Check for Blockage
  - f. Parachute Cover ..... Sealed and Secure
3. Empennage
  - a. Tiedown ..... Remove

- b. Horizontal and Vertical Stabilizers ..... Condition
- c. Elevator and Tab ..... Condition and Movement
- d. Rudder ..... Freedom of Movement
- e. Rudder Trim Tab ..... Condition and Security
- f. Attachment hinges, bolts and cotter pins ..... Secure
- 4. Right Fuselage
  - a. Static Button ..... Check for Blockage
  - b. Wing/Fuselage Fairings ..... Check
- 5. Right Wing Trailing Edge
  - a. Flap and Rub Strips (if installed) ..... Condition and Security
  - b. Aileron and Tab ..... Condition and Movement
  - c. Aileron Gap Seal ..... Security
  - d. Hinges, actuation arm, bolts, and cotter pins ..... Secure
- 6. Right Wing Tip
  - a. Tip ..... Attachment
  - b. Strobe, Nav Light and Lens ..... Condition and Security
  - c. Fuel Vent (underside) ..... Unobstructed
- 7. Right Wing Forward and Main Gear
  - a. Leading Edge and Stall Strips ..... Condition
  - b. Fuel Cap ..... Check Quantity and Secure
  - c. Stall Warning ..... Test

• Note •

With battery power on, test stall warning system by applying suction to the stall warning system inlet and noting the warning horn sounds.

- d. Fuel Drains (2 underside) ..... Drain and Sample
- e. Wheel Fairings ..... Security, Accumulation of Debris
- f. Tire ..... Condition, Inflation, and Wear
- g. Wheel and Brakes ..... Fluid Leaks, Condition and Security
- h. Chocks and Tiedown Ropes ..... Remove

- i. Cabin Air Vent..... Unobstructed
- 8. Nose, Right Side
  - a. Vortex Generator .....Condition
  - b. Cowling..... Attachments Secure
  - c. Exhaust Pipe .....Condition, Security, and Clearance
  - d. Transponder Antenna (underside) .. Condition and Attachment
  - e. Gascolator (underside) .....Drain for 3 seconds, Sample
- 9. Nose gear, Propeller, and Spinner

**• WARNING •**

Keep clear of propeller rotation plane. Do not allow others to approach propeller.

- a. Tow Bar..... Remove and Stow
- b. Strut.....Condition
- c. Wheel Fairing..... Security, Accumulation of Debris
- d. Wheel and Tire .....Condition, Inflation, and Wear
- e. Propeller ..... Condition (indentations, nicks, etc.)
- f. Spinner .....Condition, Security, and Oil Leaks
- g. Air Inlets..... Unobstructed
- h. Alternator .....Condition
- 10. Nose, Left Side
  - a. Landing Light .....Condition
  - b. Engine Oil .....Check 6-8 quarts, Leaks, Cap & Door Secure
  - c. Cowling..... Attachments Secure
  - d. External Power .....Door Secure
  - e. Vortex Generator .....Condition
  - f. Exhaust Pipe(s) .....Condition, Security, and Clearance
- 11. Left Main Gear and Forward Wing
  - a. Wheel fairings..... Security, Accumulation of Debris
  - b. Tire .....Condition, Inflation, and Wear

- c. Wheel and Brakes ..... Fluid Leaks, Condition, and Security
  - d. Chocks and Tiedown Ropes..... Remove
  - e. Fuel Drains (2 underside) ..... Drain and Sample
  - f. Cabin Air Vent.....Unobstructed
  - g. Fuel Cap ..... Check Quantity and Secure
  - h. Leading Edge and Stall Strips ..... Condition
12. Left Wing Tip
- a. Fuel Vent (underside) .....Unobstructed
  - b. Pitot Mast (underside) ..... Cover Removed, Tube Clear
  - c. Strobe, Nav Light and Lens ..... Condition and Security
  - d. Tip ..... Attachment
13. Left Wing Trailing Edge
- a. Flap And Rub Strips (If installed)..... Condition and Security
  - b. Aileron ..... Freedom of movement
  - c. Aileron Gap Seal ..... Security
  - d. Hinges, actuation arm, bolts, and cotter pins .....Secure

**Before Starting Engine**

- 1. Preflight Inspection .....COMPLETED
- 2. Emergency Equipment ..... ON BOARD
- 3. Passengers ..... BRIEFED

**• Caution •**

Crew seats must be locked in position and control handles fully down before flight.

**• Note •**

Ensure all the passengers have been fully briefed on smoking and the use of the seat belts, doors, emergency exits/hammer, and CAPS. Verify CAPS handle safety pin is removed.

- 4. Seats, Seat Belts, and Harnesses .....ADJUST & SECURE

## Starting Engine

If the engine is warm, no priming is required. For the first start of the day and in cold conditions, prime will be necessary.

### • WARNING •

If airplane will be started using external power, keep all personnel and power unit cables well clear of the propeller rotation plane. *Refer to Section 8 - Ground Handling, Servicing, and Maintenance* for special procedures and precautions when using external power.

### • Caution •

Alternators should be left OFF during engine starting to avoid high electrical loads which may shorten alternator life and cause the alternator circuit breaker to open.

1. External Power (If applicable) ..... CONNECT
2. Brakes ..... HOLD
3. Bat Master Switches ..... ON (Check Volts)
4. Strobe Lights ..... ON
5. Mixture ..... FULL RICH
6. Power Lever ..... FULL FORWARD
7. Fuel Pump ..... PRIME, then BOOST

### • Note •

*Serials 0002 - 0278 before SB 22-73-01:* On first start of the day, especially under cool ambient conditions, holding Fuel Pump switch to PRIME for 30-60 seconds will improve starting.

*Serials 0002 - 0278 after SB 22-73-01 and serials 0279 and subsequent:* On first start of the day, especially under cool ambient conditions, holding Fuel Pump switch to PRIME for 2 seconds will improve starting.

Fuel BOOST should be left ON during takeoff and for climb as required for vapor suppression with hot or warm fuel.

8. Propeller Area ..... CLEAR

- 9. Power Lever ..... OPEN ¼ INCH
- 10. Ignition Switch..... START (Release after engine starts)

**• Caution •**

Limit cranking to intervals of 20 seconds with a 20 second cooling period between cranks. This will improve battery and contactor life.

- 11. Power Lever .....RETARD (to maintain 1000 RPM)
- 12. Oil Pressure ..... CHECK
- 13. Alt Master Switches .....ON
- 14. Avionics Power Switch .....ON
- 15. Engine Parameters ..... MONITOR
- 16. External Power (If applicable) ..... DISCONNECT
- 17. Ammeter ..... CHECK

Weak intermittent firing followed by puffs of black smoke from the exhaust stack indicates overpriming or flooding. Excess fuel can be cleared from the combustion chambers by the following procedure:

- Turn fuel pump off.
- Allow fuel to drain from intake tubes.
- Set the mixture control full lean and the power lever full open.
- Crank the engine through several revolutions with the starter.
- When engine starts, release ignition switch, retard power lever, and slowly advance the mixture control to FULL RICH position.

If the engine is underprimed, especially with a cold soaked engine, it will not fire, and additional priming will be necessary. As soon as the cylinders begin to fire, open the power lever slightly to keep it running.

After starting, if the oil gauge does not begin to show pressure within 30 seconds in warm weather and about 60 seconds in very cold weather, shut down engine and investigate cause. Lack of oil pressure indicates loss of lubrication, which can cause severe engine damage.

**• Note •**

*Refer to Cold Weather Operation* in this section or additional information regarding cold weather operations.

## Before Taxiing

1. Brakes ..... CHECK
2. Flaps ..... UP (0%)
3. Radios/Avionics..... AS REQUIRED
4. Cabin Heat/Defrost ..... AS REQUIRED

## Taxiing

When taxiing, maintain directional control with rudder and differential braking. In crosswind conditions, some brake force may be required, even when taxiing at moderate speeds. Taxi over loose gravel at low engine speed to avoid damage to the propeller tips.

### • Caution •

Taxi with minimum power needed for forward movement. Excessive braking may result in overheated or damaged brakes. Damage due to overheated brakes may result in brake system malfunction or failure.

1. HSI Orientation ..... CHECK
2. Attitude Gyro ..... CHECK
3. Turn Coordinator ..... CHECK

## Before Takeoff

During cold weather operations, the engine should be properly warmed up before takeoff. In most cases this is accomplished when the oil temperature has reached at least 100° F (38° C). In warm or hot weather, precautions should be taken to avoid overheating during prolonged ground engine operation. Additionally, long periods of idling may cause fouled spark plugs.

1. CAPS Handle ..... Verify Pin Removed
2. Seat Belts and Shoulder Harness ..... SECURE
3. Doors ..... LATCHED
4. Brakes ..... HOLD
5. Flight Controls ..... FREE & CORRECT
6. Trim ..... SET Takeoff



- 7. Autopilot..... DISCONNECT
- 8. Flaps..... SET 50% & CHECK
- 9. Flight and Engine Instruments..... CHECK
- 10. HSI and Altimeter..... CHECK & SET
- 11. Fuel Quantity ..... CONFIRM
- 12. Fuel Selector..... FULLEST TANK
- 13. Propeller ..... CHECK
  - a. Power Lever..... INCREASE to detent
  - b. Note RPM rises to approximately 2000 RPM and manifold pressure increases slightly as Power Lever is set in detent.
  - c. Power Lever..... 1700 RPM
- 14. Alternator ..... CHECK
  - a. Pitot Heat..... ON
  - b. Avionics ..... ON
  - c. Navigation Lights ..... ON
  - d. Landing Light..... ON (3-5 seconds)
  - e. Verify both ALT 1 and ALT 2 caution lights out and positive amps indication for each alternator. If necessary, increase RPM to extinguish ALT 2 caution light. ALT 2 caution light shall go out below 2200 RPM.

• Note •

The alternators require battery power to restart. Do not turn off alternators in flight unless required for safe flight

- 15. Voltage..... CHECK
- 16. Magnetos ..... CHECK Left and Right
  - a. Ignition Switch ..... R, note RPM, then BOTH
  - b. Ignition Switch ..... L, note RPM, then BOTH

• Note •

RPM drop must not exceed 150 RPM for either magneto. RPM differential must not exceed 75 RPM between magnetos. If there is a doubt concerning operation of the ignition system,

RPM checks at higher engine speeds will usually confirm whether a deficiency exists.

An absence of RPM drop may indicate faulty grounding of one side of the ignition system or magneto timing set in advance of the specified setting.

- 17. Power Lever ..... DECREASE to 1000 RPM
- 18. Transponder .....ALT
- 19. Navigation Radios/GPS ..... SET for Takeoff
- 20. Pitot Heat ..... AS REQUIRED

• Note •

Pitot heat should be turned ON prior to flight into IMC or flight into visible moisture and OAT of 40° F (4° C) or less.

**Maximum Power Fuel Flow**

Leaning for Takeoff and Maximum Climb is accomplished at full throttle by leaning the mixture from full rich to the target fuel flow for the given pressure altitude. The fuel flow values in the table below were demonstrated to obtain the takeoff and climb performance presented in Section 5.

• Note •

Excessively rich mixture will occur if the Mixture control is set to FULL RICH above 7500 feet pressure altitude.

Pressure Altitude	Target Fuel Flow	Pressure Altitude	Target Fuel Flow	Pressure Altitude	Target Fuel Flow
0	27.1	7000	21.4	14,000	17.5
1000	26.2	8000	20.5	15,000	16.9
2000	25.1	9000	19.9	16,000	16.7
3000	24.3	10,000	19.5	17,000	16.2
4000	23.6	11,000	18.8	17,500	16.1
5000	22.8	12,000	18.4		
6000	22.1	13,000	17.9		

## Takeoff

**Power Check:** Check full-throttle engine operation early in takeoff run. The engine should run smoothly and turn approximately 2700 RPM. All engine instruments should read in the green. Discontinue takeoff at any sign of rough operation or sluggish acceleration. Make a thorough full-throttle static runup before attempting another takeoff.

For takeoff over a gravel surface, advance Power Lever slowly. This allows the airplane to start rolling before high RPM is developed, and gravel will be blown behind the propeller rather than pulled into it.

**Flap Settings:** Takeoffs are approved at flaps UP (0%) or flaps 50%. Normal and short field takeoffs are accomplished with flaps set at 50%. Takeoffs using 50% flaps require less ground roll and distance over an obstacle than do takeoffs with no flaps. Takeoff flap settings greater than 50% are not approved.

Soft or rough field takeoffs are performed with 50% flaps by lifting the airplane off the ground as soon as practical in a tail-low attitude. If no obstacles are ahead, the airplane should be leveled off immediately to accelerate to a higher climb speed.

Takeoffs into strong crosswinds normally are performed with the minimum flap setting (0% or 50%) necessary for the field length, to minimize the drift angle immediately after takeoff. With the ailerons partially deflected into the wind, accelerate the airplane to a speed slightly higher than normal, and then pull it off abruptly to prevent possibly settling back to the runway while drifting. When clear of the ground, make a coordinated turn into the wind to correct for drift.

## Normal Takeoff

1. Power Lever ..... FULL FORWARD
2. Engine Instruments ..... CHECK
3. Brakes ..... RELEASE (Steer with Rudder Only)
4. Elevator Control ..... ROTATE Smoothly at 70-73 KIAS
5. At 80 KIAS, Flaps ..... UP

## Short Field Takeoff

1. Flaps .....50%
2. Brakes ..... HOLD
3. Power Lever ..... FULL FORWARD
4. Mixture ..... SET
5. Engine Instruments ..... CHECK
6. Brakes ..... RELEASE (Steer with Rudder Only)
7. Elevator Control ..... ROTATE Smoothly at 70 KIAS
8. Airspeed at Obstacle.....78 KIAS

## Climb

Normal climbs are performed flaps UP (0%) and full power at speeds 5 to 10 knots higher than best rate-of-climb speeds. These higher speeds give the best combination of performance, visibility and engine cooling.

For maximum rate of climb, use the best rate-of-climb speeds shown in the rate-of-climb chart in Section 5. If an obstruction dictates the use of a steep climb angle, the best angle-of-climb speed should be used. Climbs at speeds lower than the best rate-of-climb speed should be of short duration to avoid engine-cooling problems.

1. Climb Power ..... SET
2. Mixture ..... LEAN as required for altitude
3. Engine Instruments ..... CHECK
4. Fuel Pump..... OFF

• Note •

The Fuel Pump may be used for vapor suppression during climb. Fuel BOOST should be left on above 6000 feet pressure altitude if takeoff was made with hot or warm fuel.

## Cruise

Normal cruising is performed between 55% and 85% power. The engine power setting and corresponding fuel consumption for various altitudes and temperatures can be determined by using the cruise data in Section 5.

The selection of cruise altitude is made based on the most favorable wind conditions and the desired power settings. These significant factors should be considered on every trip to reduce consumption.

• Note •

For engine break-in, cruise at a minimum of 75% power until the engine has been operated for at least 25 hours or until oil consumption has stabilized. Operation at this higher power will ensure proper seating of the rings, is applicable to new engines, and engines in service following cylinder replacement or top overhaul of one or more cylinders.

1. Cruise Power..... SET
2. Engine Instruments..... MONITOR
3. Fuel Flow and Balance ..... MONITOR

• Note •

Fuel BOOST must be used for switching from one tank to another. Failures to activate the Fuel Pump before transfer could result in delayed restart if the engine should quit due to fuel starvation.

4. Mixture .....LEAN as required

## Cruise Leaning

Exhaust gas temperature (EGT) may be used as an aid for mixture leaning in cruise flight. **For “Best Power” use 75% power or less. For “Best Economy” use 65% power or less.** To adjust the mixture, lean to establish the peak EGT as a reference point and then adjust the mixture by the desired increment based on the following table:

Mixture Description	Exhaust Gas Temperature
Best Power	75° F Rich Of Peak EGT
Best Economy	50° F Lean Of Peak EGT

Under some conditions, engine roughness may occur while operating at best economy. If this occurs, enrich mixture as required to smooth engine operation. Any change in altitude or Power Lever position will require a recheck of EGT indication.

## Descent

1. Altimeter ..... SET
2. Cabin Heat/Defrost ..... AS REQUIRED
3. Fuel System ..... CHECK
4. Mixture ..... AS REQUIRED
5. Flaps ..... AS REQUIRED
6. Brake Pressure ..... CHECK

## Before Landing

1. Seat Belt and Shoulder Harness ..... SECURE
2. Mixture ..... FULL RICH
3. Fuel Pump ..... BOOST
4. Flaps ..... AS REQUIRED
5. Landing Light ..... AS REQUIRED
6. Autopilot ..... DISENGAGE

## Landing

### • Caution •

Landings should be made with full flaps. Landings with less than full flaps are recommended only if the flaps fail to deploy or to extend the aircraft's glide distance due to engine malfunction. Landings with flaps at 50% or 0%; power should be used to achieve a normal glidepath and low descent rate. Flare should be minimized.

### ***Normal Landing***

Normal landings are made with full flaps with power on or off. Surface winds and air turbulence are usually the primary factors in determining the most comfortable approach speeds.

Actual touchdown should be made with power off and on the main wheels first to reduce the landing speed and subsequent need for braking. Gently lower the nose wheel to the runway after airplane speed has diminished. This is especially important for rough or soft field landings.

### ***Short Field Landing***

For a short field landing in smooth air conditions, make an approach at 77 KIAS with full flaps using enough power to control the glide path (slightly higher approach speeds should be used under turbulent air conditions). After all approach obstacles are cleared, progressively reduce power to reach idle just before touchdown and maintain the approach speed by lowering the nose of the airplane. Touchdown should be made power-off and on the main wheels first. Immediately after touchdown, lower the nose wheel and apply braking as required. For maximum brake effectiveness, retract the flaps, hold the control yoke full back, and apply maximum brake pressure without skidding.

### ***Crosswind Landing***

Normal crosswind landings are made with full flaps. Avoid prolonged slips. After touchdown, hold a straight course with rudder and brakes as required. The maximum allowable crosswind velocity is dependent upon pilot capability as well as aircraft limitations. Operation in direct crosswinds of 20 knots has been demonstrated.

## Balked Landing/Go-Around

In a balked landing (go around) climb, disengage autopilot, apply full power, then reduce the flap setting to 50%. If obstacles must be cleared during the go around, climb at 75-80 KIAS with 50% flaps. After clearing any obstacles, retract the flaps and accelerate to the normal flaps up climb speed.

1. Autopilot .....DISENGAGE
2. Power Lever .....FULL FORWARD
3. Flaps .....50%
4. Airspeed..... 75-80 KIAS

*After clear of obstacles:*

5. Flaps ..... UP

## After Landing

1. Flaps ..... UP
2. Power Lever ..... 1000 RPM
3. Transponder ..... STBY

• Note •

As the airplane slows the rudder becomes less effective and taxiing is accomplished using differential braking.

4. Pitot Heat ..... OFF
5. Fuel Pump..... OFF



## Shutdown

1. Avionics Switch ..... OFF
2. Fuel Pump (if used) ..... OFF
3. Mixture ..... CUTOFF
4. Magnetos ..... OFF
5. Bat-Alt Master Switches ..... OFF
6. ELT ..... TRANSMIT LIGHT OUT

• Note •

After a hard landing, the ELT may activate. If this is suspected, press the RESET button.

7. Chocks, Tie-downs, Pitot Covers ..... AS REQUIRED

## Stalls

SR22 stall characteristics are conventional. Power-off stalls may be accompanied by a slight nose bobbing if full aft stick is held. Power-on stalls are marked by a high sink rate at full aft stick. Power-off stall speeds at maximum weight for both forward and aft C.G. positions are presented in Section 5 - Performance Data.

When practicing stalls at altitude, as the airspeed is slowly reduced, you will notice a slight airframe buffet and hear the stall speed warning horn sound between 5 and 10 knots before the stall. Normally, the stall is marked by a gentle nose drop and the wings can easily be held level or in the bank with coordinated use of the ailerons and rudder. Upon stall warning in flight, recovery is accomplished by immediately by reducing back pressure to maintain safe airspeed, adding power if necessary and rolling wings level with coordinated use of the controls.

### • WARNING •

Extreme care must be taken to avoid uncoordinated, accelerated or abused control inputs when close to the stall, especially when close to the ground.

# Environmental Considerations

## Cold Weather Operation

### *Starting*

If the engine has been cold soaked, it is recommended that the propeller be pulled through by hand several times to break loose or limber the oil. This procedure will reduce power draw on the battery if a battery start is made.

When the engine has been exposed to temperatures at or below 20° Fahrenheit (-7° C) for a period of two hours or more, the use of an external pre-heater and external power is recommended. Failure to properly preheat a cold-soaked engine may result in oil congealing within the engine, oil hoses, and oil cooler with subsequent loss of oil flow, possible internal damage to the engine, and subsequent engine failure.

### • Caution •

Inadequate application of preheat to a cold soaked engine may warm the engine enough to permit starting but will not de-congeal oil in the sump, lines, cooler, filter, etc. Congealed oil in these areas will require considerable preheat.

An engine that has been superficially warmed, may start and appear to run satisfactorily, but can be damaged from lack of lubrication due to the congealed oil blocking proper oil flow through the engine. The amount of damage will vary and may not become evident for many hours. However, the engine may be severely damaged and may fail shortly following application of high power. Proper procedures require thorough application of preheat to all parts of the engine. Hot air must be applied directly to the oil sump and external oil lines as well as the cylinders, air intake and oil cooler. Because excessively hot air can damage non-metallic components such as composite parts, seals, hoses, and drives belts, do not attempt to hasten the preheat process.

• **WARNING** •

If airplane will be started using external power, keep all personnel and power unit cables well clear of the propeller rotation plane. *Refer to Section 8 - Ground Handling, Servicing, and Maintenance* for special procedures and precautions when using external power.

1. Ignition switch.....OFF

• **WARNING** •

Use extreme caution when pulling the propeller through by hand. Make sure ignition switch is OFF, keys are out of ignition, and then act as if the engine will start. A loose or broken ground wire on either magneto could cause the engine to fire.

2. Propeller..... Hand TURN several rotations  
3. External Power (If applicable) ..... CONNECT  
4. Brakes ..... HOLD  
5. Bat Master Switches ..... ON (check voltage)  
6. Mixture ..... FULL RICH  
7. Power lever.....FULL FORWARD  
8. Fuel Pump.....PRIME, then BOOST

• **Note** •

Serials 0002 - 0278 before SB 22-73-01: In temperatures down to 20°F, hold Fuel Pump switch to PRIME for 60-120 seconds prior to starting.

Serials 0002 - 0278 after SB 22-73-01 and 0279 and subsequent: In temperatures down to 20°F, hold Fuel Pump switch to PRIME for 15 seconds prior to starting.

9. Propeller Area ..... CLEAR  
10. Power Lever ..... OPEN ¼ INCH  
11. Ignition Switch ..... START (Release after engine starts)

• **Caution** •

Limit cranking to intervals of 20 seconds with a 20 second cooling period between cranks. This will improve battery and contactor life

- 12. Power Lever .....RETARD (to maintain 1000 RPM)
- 13. Oil Pressure ..... CHECK
- 14. Alt Master Switches .....ON
- 15. Avionics Power Switch .....ON
- 16. Engine Parameters ..... MONITOR
- 17. External Power (If applicable) ..... DISCONNECT
- 18. Ammeter ..... CHECK
- 19. Strobe Lights.....ON

If the engine does not start during the first few attempts, or if engine firing diminishes in strength, the spark plugs have probably frosted over. Preheat must be used before another start is attempted.

If outside air temperatures are very low, the oil temperature gage may not indicate increasing oil temperature prior to takeoff. In this event, allow a suitable warm-up period (two to five minutes at 1000 RPM); then accelerate the engine several times to a higher RPM. If the engine accelerates smoothly and the oil pressure remains normal and steady, continue with a normal takeoff.

## Hot Weather Operation

Avoid prolonged engine operation on the ground.

• Note •

Fuel BOOST must be ON for engine start and takeoff, and should be ON during climb for vapor suppression such as could occur under hot ambient conditions or after extended idle.

## Noise Characteristics/Abatement

The certificated noise levels for the Cirrus Design SR22 established in accordance with FAR 36 Appendix G are:

Configuration	Actual	Maximum Allowable
Hartzel 3-blade Propeller PHC-J3YF-1RF/F7694	83.65 dB(A)	88.00 dB(A)
Hartzel 3-blade Propeller PHC-J3YF-1RF/F7693DF	84.81 dB(A)	88.00 dB(A)
McCaughey 3-blade Propeller D3A34C443/78CYA-0	83.15 dB(A)	88.00 dB(A)

No determination has been made by the Federal Aviation Administration that the noise levels of this airplane are or should be acceptable or unacceptable for operation at, into, or out of, any airport. The above noise levels were established at 3400 pounds takeoff weight and 2700 RPM.

Recently, increased emphasis on improving environmental quality requires all pilots to minimize the effect of airplane noise on the public. The following suggested procedures minimize environmental noise when operating the SR22.

• Note •

Do not follow these noise abatement procedures where they conflict with Air Traffic Control clearances or instructions, weather considerations, or wherever they would reduce safety.

1. When operating VFR over noise-sensitive areas, such as outdoor events, parks, and recreational areas, fly not less than 2000 feet above the surface even though flight at a lower level may be allowed.
2. For departure from or approach to an airport, avoid prolonged flight at low altitude near noise-sensitive areas.

## **Fuel Conservation**

Minimum fuel use at cruise will be achieved using the best economy power setting described under cruise.

Intentionally Left Blank



# **Section 5**

## **Performance Data**

### **Table of Contents**

Introduction .....	5-3
Associated Conditions Affecting Performance .....	5-3
Flight Planning .....	5-4
Sample Problem .....	5-4
Takeoff .....	5-5
Climb .....	5-6
Cruise .....	5-7
Fuel Required .....	5-8
Landing .....	5-9
Demonstrated Operating Temperature .....	5-9
Airspeed Calibration .....	5-10
Normal Static Source .....	5-10
Airspeed Calibration .....	5-11
Alternate Static Source .....	5-11
Altitude Correction .....	5-12
Normal Static Source .....	5-12
Altitude Correction .....	5-13
Alternate Static Source .....	5-13
Temperature Conversion .....	5-14
Outside Air Temperature for ISA Condition .....	5-15
Stall Speeds .....	5-16
Wind Components .....	5-17
Takeoff Distance .....	5-18
Takeoff Distance .....	5-19
Takeoff Distance .....	5-20
Takeoff Climb Gradient .....	5-21
Takeoff Rate of Climb .....	5-22
Enroute Climb Gradient .....	5-23
Enroute Rate of Climb .....	5-24
Time, Fuel and Distance to Climb .....	5-25
Cruise Performance .....	5-26
Cruise Performance .....	5-27
Cruise Performance .....	5-28

**Section 5**  
**Performance Data**

**Cirrus Design**  
**SR22**

Range / Endurance Profile ..... 5-29  
Range / Endurance Profile ..... 5-30  
Range / Endurance Profile ..... 5-31  
Balked Landing Climb Gradient ..... 5-32  
Balked Landing Rate of Climb..... 5-33  
Landing Distance ..... 5-34  
Landing Distance ..... 5-35

## Introduction

Performance data in this section are presented for operational planning so that you will know what performance to expect from the airplane under various ambient and field conditions. Performance data are presented for takeoff, climb, and cruise (including range & endurance).

### Associated Conditions Affecting Performance

Computed performance data in this section are based upon data derived from actual flight testing with the airplane and engine in good condition and using average piloting techniques. Unless specifically noted in the “Conditions” notes presented with each table, ambient conditions are for a standard day (*refer to Section 1*). Flap position as well as power setting technique is similarly noted with each table.

The charts in this section provide data for ambient temperatures from  $-20^{\circ}\text{C}$  ( $-4^{\circ}\text{F}$ ) to  $40^{\circ}\text{C}$  ( $104^{\circ}\text{F}$ ). If ambient temperature is below the chart value, use the lowest temperature shown to compute performance. This will result in more conservative performance calculations. **If ambient temperature is above the chart value, use extreme caution as performance degrades rapidly at higher temperatures.**

All fuel flow data for cruise is based on the recommended lean mixture setting detailed in Section 4 – Normal Procedures.

## Flight Planning

The performance tables in this section present sufficient information to predict airplane performance with reasonable accuracy. However, variations in fuel metering, mixture leaning technique, engine & propeller condition, air turbulence, and other variables encountered during a particular flight may account for variations of 10% or more in range and endurance. Therefore, utilize all available information to estimate the fuel required for a particular flight.

• Note •

Whenever possible, select the most conservative values from the following charts to provide an extra margin of safety and to account for events that could occur during a flight.

### Sample Problem

The following sample flight problem uses information derived from the airplane performance charts and tables to determine the predicted performance for a typical flight.

The first step in flight planning is to determine the aircraft weight and center of gravity, as well as information about the flight. For this sample problem, the following information is known:

***Airplane Configuration:***

- Takeoff weight.....3400 Pounds
- Usable fuel.....81 Gallons

***Takeoff Conditions:***

- Field pressure altitude ..... 1750 Feet
- Temperature .....25° C (ISA + 13° C)
- Wind component along runway .....11 knot headwind
- Runway Condition .....Dry, level, paved
- Field length.....3000 Feet

***Cruise Conditions:***

- Total distance..... 560 Nautical Miles
- Pressure altitude.....6500 Feet
- Temperature .....20° C (ISA + 17° C)

- Expected wind enroute..... 10 Knot Headwind

**Landing Conditions:**

- Field pressure altitude ..... 2000 Feet
- Temperature .....20° C (ISA + 10° C)
- Field length..... 3000 Feet

**Takeoff**

The takeoff distance tables, Figure 5-9, show the takeoff ground roll and horizontal distance to reach 50 feet above ground level. The distances shown are based on the short field technique.

Conservative distances can be established by reading the tables at the next higher value of weight, altitude and temperature. For example, in this particular sample problem, the takeoff distance information presented for a weight of 3400 pounds, takeoff field pressure altitude of 2000 feet, and a temperature of 30° C should be used. Using the conservative values results in the following:

- Ground roll ..... 1385 Feet
- Total distance to clear a 50 foot obstacle ..... 2107 Feet

Since the takeoff distance tables are based upon a zero wind conditions, a correction for the effect of winds must be made. Use the wind components chart, Figure 5-8 to determine the crosswind and the headwind (or tailwind) component of the reported winds.

Using the 11-knot headwind component, the following corrections can be made:

- Correction for headwind (10% for each 12 knots) .....9.2%
- Ground roll, zero wind ..... 1385 feet
- Decrease in ground roll (1385 feet x 0.092) ..... 127 feet
- Corrected ground roll..... 1258 feet
- Total distance to clear a 50 foot obstacle, zero wind... 2107 feet
- Decrease in total distance (2107 feet x 0.092)..... 194 feet
- Corrected total distance to clear 50 foot obstacle ..... 1913 feet

Corrections for grass runways and sloped runways are also applicable and should be applied. These corrections are calculated in the same

manner as the wind correction above. Refer to Figure 5-9 for correction factors to be applied.

## Climb

The takeoff and enroute rate-of-climb and climb gradient tables, Figures 5-10 through 5-13, present maximum rate of climb and climb gradient for various conditions. The time, fuel, and distance to climb table, Figure 5-14, allows determination of the time, fuel, and distance to climb from sea level to a specified pressure altitude. To determine the values to be used for flight planning, the start-of-climb time, fuel, and distance values are subtracted from the end-of-climb (cruise altitude) values. Again, conservative values are obtained by using the next lower altitude value for start of climb or next higher altitude values for end of climb. Using conservative values for the sample data, the following calculations are made:

### **Start-of-climb values (SL to 1750 feet):**

- Time to climb ..... 0.7 minutes
- Distance to climb ..... 1.0 NM
- Fuel to climb ..... .0.3 Gal.

### **End-of-climb values (SL to 6500 feet):**

- Time to climb ..... 6.0 minutes
- Distance to climb ..... 10.5 NM
- Fuel to climb ..... 2.4 Gal.

### **Climb values (1750 to 6500 feet):**

- Time to climb (end 6.0 - start 0.7) ..... 5.3 minutes
- Distance to climb (end 10.5 - start 1.0) ..... 9.5 NM
- Fuel to climb (end 2.4 - start 0.3) ..... 2.1 Gal.

The above values reflect climb for a standard day and are sufficient for most flight planning. However, further correction for the effect of temperature on climb can be made. The effect of a temperature on climb performance is to increase the time, fuel, and distance to climb by approximately 10% for each 10° C above ISA. In our example, using a temperature of ISA + 13° C, the correction to be applied is 13%.

***The fuel estimate for climb is:***

- Fuel to climb (standard temperature) ..... 2.1 Gal.
- Increase due to non-standard temp (2.1 x 0.13) ..... 0.3 Gal.
- Corrected fuel to climb (2.1 + 0.3) ..... 2.4 Gal.

***Procedure for the distance to climb is:***

- Distance to climb, standard temperature ..... 9.5 NM
- Increase due to non-standard temp (9.5 x 0.13) ..... 1.2 NM
- Corrected distance to climb (9.5 + 1.2) ..... 10.7 NM

**Cruise**

The selected cruise altitude should be based upon airplane performance, trip length, and winds aloft. A typical cruise altitude and the expected winds aloft are given for this sample problem. Power selection for cruise should be based upon the cruise performance characteristics tabulated in Figure 5-15, and the range/endurance profile for maximum power is presented in Figure 5-16.

The relationship between power and range as well as endurance is shown in the range/endurance profile chart, Figure 5-16. Note that fuel economy and range are substantially improved at lower power settings.

The cruise performance chart, Figure 5-15, is entered at 6000 feet altitude and 30° C above standard temperature. These values are conservative for the planned altitude and expected temperature conditions. The engine speed chosen is 2500 RPM at approximately 55% power, which results in the following:

- Power (MAP = 19.5) ..... 56%
- True airspeed ..... 157 Knots
- Cruise fuel flow ..... 15.3 GPH

## Fuel Required

The total fuel requirement for the flight may be estimated using the performance information obtained from Figures 5-14 and 5-15. The resultant cruise distance is:

- Total distance (from sample problem) ..... 560.0 NM
- Climb distance (corrected value from climb table)..... 10.7 NM
- Cruise distance (total distance - climb distance) ..... 549.3 NM

Using the predicted true airspeed from the cruise performance table, Figure 5-15, and applying the expected 10-knot headwind, the ground speed for cruise is expected to be 147 knots. Therefore, the time required for the cruise portion of the trip is:

- $549.3 \text{ NM} / 147 \text{ knots} = 3.7 \text{ hours}$ .

The fuel required for cruise is:

- $3.7 \text{ hours} \times 15.3 \text{ GPH} = 56.6 \text{ gallons}$ .

From the 6000 ft Cruise Table (Figure 5-15), a 45 minute IFR reserve at approximately 55% power requires:

- $45/60 \times 15.3 \text{ GPH} = 11.5 \text{ gallons}$

The total estimated fuel required is as follows:

- Engine start, taxi, and takeoff ..... 1.5 gallons
- Climb ..... 2.4 gallons
- Cruise ..... 56.6 gallons
- Reserve ..... 11.5 gallons
- Total fuel required ..... 72.0 gallons

Once the flight is underway, ground speed checks will provide a more accurate basis for estimating the time enroute and the corresponding fuel required to complete the trip with ample reserve.



## Landing

A procedure similar to takeoff should be used for estimating the landing distance at the destination airport. Figure 5-19 presents landing distance information for the short field technique. The distances corresponding to 2000 feet and 20° C are as follows:

- Ground roll ..... 1248 Feet
- Total distance to land over a 50 foot obstacle ..... 2476 Feet

A correction for the effect of wind may be made based on the headwind and tailwind corrections presented with the landing chart using the same procedure as outlined for takeoff. Corrections for runway slope and dry grass may also be applied in like manner.

## Demonstrated Operating Temperature

Satisfactory engine cooling has been demonstrated for this airplane with an outside air temperature 23° C above standard. The value given is not considered an operating limitation. Reference should be made to Section 2 for engine operating limitations.

# Airspeed Calibration

## Normal Static Source

**Conditions:**

- Power for level flight or maximum continuous, whichever is less.

**Example:**

Flaps ..... 50%  
 Indicated Airspeed ..... 85 Knots  

---

 Calibrated Airspeed ..... 85 Knots

• Note •

- Indicated airspeed values assume zero instrument error.
- KIAS = Knots Indicated Airspeed
- KCAS = Knots Calibrated Airspeed

KIAS	KCAS		
	Flaps 0%	Flaps 50%	Flaps 100%
60			58
70		68	69
80	79	80	80
90	90	91	90
100	100	101	100
110	110	111	
120	121	121	
130	131		
140	142		
150	152		
160	162		
170	172		
180	183		
190	193		
200	203		

Figure 5-1

# Airspeed Calibration

## Alternate Static Source

**Conditions:**

- Power for level flight or maximum continuous, whichever is less.
- Heater, Defroster & Vents .....ON

**Example:**

Flaps.....50%  
 Indicated Airspeed.....85 Knots  

---

 Calibrated Airspeed.....86 Knots

• Note •

- Indicated airspeed values assume zero instrument error.
- KIAS = Knots Indicated Airspeed
- KCAS = Knots Calibrated Airspeed

KIAS	KCAS		
	Flaps 0%	Flaps 50%	Flaps 100%
60			62
70		71	73
80	80	81	82
90	90	91	92
100	100	101	101
110	110	111	
120	120	121	
130	130		
140	140		
150	150		
160	160		
170	170		
180	180		
190	190		
200	199		

**Figure 5-2**

# Altitude Correction

## Normal Static Source

**Conditions:**

- Power for level flight or maximum continuous, whichever is less.

**Example:**

Flaps ..... 0%  
 Indicated Airspeed ..... 120 Knots  
 Desired Altitude..... 12,000 FT  
 Altitude Correction ..... -13 FT

---

Altitude to Fly ..... 11,987 FT

• Note •

- Indicated airspeed values assume zero instrument error.
- KIAS = Knots Indicated Airspeed
- KCAS = Knots Calibrated Airspeed

Flaps	Press Alt	CORRECTION TO BE ADDED - FEET									
		Normal Static Source - KIAS									
		60	70	80	90	100	120	140	160	180	200
0%	S.L		8	6	3	0	-9	-19	-31	-44	-56
	5000		10	7	4	0	-10	-23	-36	-51	-65
	10000		11	8	5	0	-12	-26	-42	-59	-76
	15000		13	10	5	0	-14	-31	-50	-70	-90
50%	S.L		14	3	-6	-12	-6				
	5000		17	4	-7	-14	-7				
	10000		19	4	-9	-17	-8				
100%	S.L	13	8	3	0	-1					
	5000	15	9	3	0	-1					
	10000	17	10	4	0	-2					

**Figure 5-3**

## Altitude Correction Alternate Static Source

**Conditions:**

- Power for level flight or maximum continuous, whichever is less.
- Heater, Defroster, & Vents.....ON

**Example:**

Flaps.....0%  
 Indicated Airspeed..... 120 Knots  
 Desired Altitude ..... 12,000 FT  
 Altitude Correction..... -4 FT

---

Altitude to Fly..... 11,996 FT

• Note •

- Indicated airspeed values assume zero instrument error.
- KIAS = Knots Indicated Airspeed
- KCAS = Knots Calibrated Airspeed

Flaps	Press Alt	CORRECTION TO BE ADDED - FEET									
		Normal Static Source - KIAS									
		60	70	80	90	100	120	140	160	180	200
0%	S.L		1	0	-1	-1	-3	-3	-1	4	13
	5000		2	0	-1	-2	-3	-3	-1	5	15
	10000		2	1	-1	-2	-4	-4	-1	6	18
	15000		2	1	-1	-2	-4	-4	-1	7	21
50%	S.L		-7	-6	-5	-5	-9				
	5000		-8	-7	-6	-6	-10				
	10000		-9	-8	-7	-7	-12				
100%	S.L	-14	-17	-18	-16	-10					
	5000	-16	-20	-21	-19	-12					
	10000	-18	-23	-25	-22	-14					

**Figure 5-4**

## Temperature Conversion

• Note •

- To convert from Celsius (°C) to Fahrenheit (°F), find, in the shaded columns, the number representing the temperature value (°C) to be converted. The equivalent Fahrenheit temperature is read to the right.  
→ **EXAMPLE:** 38° C = 100° F.
- To convert from Fahrenheit (°F) to Celsius (°C), find in the shaded columns area, the number representing the temperature value (°F) to be converted. The equivalent Celsius temperature is read to the left.  
→ **EXAMPLE:** 38° F = 3° C.

Temp to Convert °C or °F			Temp to Convert °C or °F			Temp to Convert °C or °F		
°C	↔	°F	°C	↔	°F	°C	↔	°F
-50	<b>-58</b>	-72	-17	<b>2</b>	36	17	<b>62</b>	144
-49	<b>-56</b>	-69	-16	<b>4</b>	39	18	<b>64</b>	147
-48	<b>-54</b>	-65	-14	<b>6</b>	43	19	<b>66</b>	151
-47	<b>-52</b>	-62	-13	<b>8</b>	46	20	<b>68</b>	154
-46	<b>-50</b>	-58	-12	<b>10</b>	50	21	<b>70</b>	158
-44	<b>-48</b>	-54	-11	<b>12</b>	54	22	<b>72</b>	162
-43	<b>-46</b>	-51	-10	<b>14</b>	57	23	<b>74</b>	165
-42	<b>-44</b>	-47	-9	<b>16</b>	61	24	<b>76</b>	169
-41	<b>-42</b>	-44	-8	<b>18</b>	64	26	<b>78</b>	172
-40	<b>-40</b>	-40	-7	<b>20</b>	68	27	<b>80</b>	176
-39	<b>-38</b>	-36	-6	<b>22</b>	72	28	<b>82</b>	180
-38	<b>-36</b>	-33	-4	<b>24</b>	75	29	<b>84</b>	183
-37	<b>-34</b>	-29	-3	<b>26</b>	79	30	<b>86</b>	187
-36	<b>-32</b>	-26	-2	<b>28</b>	82	31	<b>88</b>	190
-34	<b>-30</b>	-22	-1	<b>30</b>	86	32	<b>90</b>	194
-33	<b>-28</b>	-18	0	<b>32</b>	90	33	<b>92</b>	198
-32	<b>-26</b>	-15	1	<b>34</b>	93	34	<b>94</b>	201
-31	<b>-24</b>	-11	2	<b>36</b>	97	36	<b>96</b>	205
-30	<b>-22</b>	-8	3	<b>38</b>	100	37	<b>98</b>	208
-29	<b>-20</b>	-4	4	<b>40</b>	104	38	<b>100</b>	212
-28	<b>-18</b>	0	6	<b>42</b>	108	39	<b>102</b>	216
-27	<b>-16</b>	3	7	<b>44</b>	111	40	<b>104</b>	219
-26	<b>-14</b>	7	8	<b>46</b>	115	41	<b>106</b>	223
-24	<b>-12</b>	10	9	<b>48</b>	118	42	<b>108</b>	226
-23	<b>-10</b>	14	10	<b>50</b>	122	43	<b>110</b>	230
-22	<b>-8</b>	18	11	<b>52</b>	126	44	<b>112</b>	234
-21	<b>-6</b>	21	12	<b>54</b>	129	46	<b>114</b>	237
-20	<b>-4</b>	25	13	<b>56</b>	133	47	<b>116</b>	241
-19	<b>-2</b>	28	14	<b>58</b>	136	48	<b>118</b>	244
-18	<b>0</b>	32	16	<b>60</b>	140	49	<b>120</b>	248

Figure 5-5

## Outside Air Temperature for ISA Condition

**Example:**

Pressure Altitude.....8000 FT  
Outside Air Temp..... 48° F

---

ISA Condition ..... ISA + 10° C

Press Alt Feet	ISA-40°C		ISA-20°C		ISA		ISA+10°C		ISA+20°C	
	°C	°F	°C	°F	°C	°F	°C	°F	°C	°F
SL	-25	-13	-5	23	15	59	25	77	35	95
1000	-27	-18	-7	18	13	54	23	72	33	90
2000	-29	-20	-9	16	11	52	21	70	31	88
3000	-31	-24	-11	12	9	48	19	66	29	84
4000	-33	-27	-13	9	7	45	17	63	27	81
5000	-35	-31	-15	5	5	41	15	59	25	77
6000	-37	-34	-17	2	3	38	13	56	23	74
7000	-39	-38	-19	-2	1	34	11	52	21	70
8000	-41	-42	-21	-6	-1	30	10	48	20	66
9000	-43	-45	-23	-9	-3	27	7	45	17	63
10000	-45	-49	-25	-13	-5	23	5	41	15	59
11000	-47	-52	-27	-16	-7	20	3	38	13	56
12000	-49	-56	-29	-20	-9	16	1	34	11	52
13000	-51	-59	-31	-23	-11	13	-1	31	9	49
14000	-53	-63	-33	-27	-13	9	-3	27	7	45
15000	-55	-67	-35	-31	-15	6	-5	23	5	41
16000	-57	-71	-37	-34	-17	2	-7	20	3	38
17000	-59	-75	-39	-38	-19	-2	-9	16	1	34
17500	-60	-76	-40	-40	-20	-3	-10	14	0	32

**Figure 5-6**

## Stall Speeds

**Conditions:**

- Weight ..... 3400 LB
- C.G. .... Noted
- Power..... Idle
- Bank Angle ..... Noted

**Example:**

- Flaps ..... Up (0%)
  - Bank Angle..... 15°
  - C.G..... Forward
- 
- Stall Speed..... 71 KIAS | 70 KCAS

• Note •

- Altitude loss during wings level stall may be 250 feet or more.
- KIAS values may not be accurate at stall.

Weight	Bank Angle	STALL SPEEDS					
		Flaps 0%Full Up		Flaps 50%		Flaps 100%Full Down	
LB	Deg	KIAS	KCAS	KIAS	KCAS	KIAS	KCAS
3400 Most FWD C.G.	0	70	69	67	64	59	59
	15	71	70	68	65	62	60
	30	75	74	72	69	66	64
	45	84	82	80	76	73	70
	60	99	97	95	90	87	84
3400 Most AFT C.G.	0	68	67	66	62	61	59
	15	69	68	67	63	62	60
	30	73	72	71	67	65	63
	45	81	79	78	74	72	70
	60	96	94	93	88	86	83

Figure 5-7



# Wind Components

**Conditions:**

- Runway Heading ..... 10°
- Wind Direction ..... 60°
- Wind Velocity ..... 15 Knots

**Example:**

- Wind/Flight Path Angle ..... 50°
- Crosswind Component ..... 12 Knots
- Headwind Component ..... 10 Knots

• Note •

- The maximum demonstrated crosswind is 20 knots. Value not considered limiting.

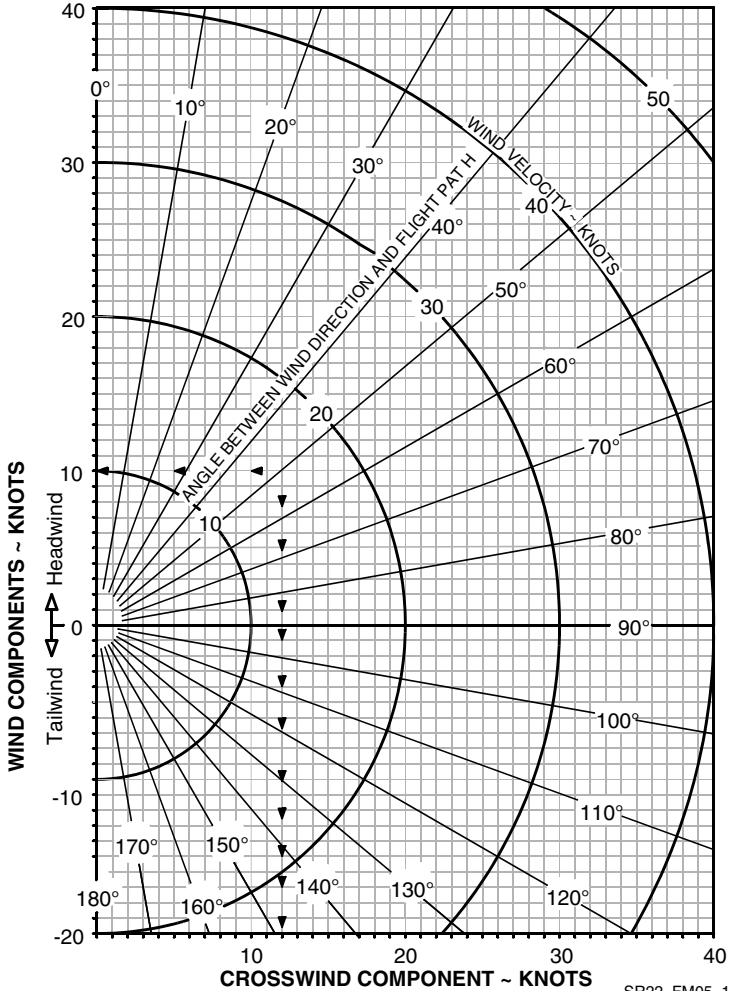

SR22\_FM05\_1014

Figure 5-8

## Takeoff Distance

**Conditions:**

- Winds..... Zero
- Runway..... Dry, Level, Paved
- Flaps..... 50%
- Power..... Full Throttle
- Mixture..... Set per Placard

**Example:**

- Outside Air Temp ..... 25°C
- Weight..... 3400 LB
- Pressure Altitude..... 2000 FT
- Headwind ..... 12 Knots
- Runway ..... Dry, Paved

- 
- Liftoff Speed..... 73 KIAS
  - Obstacle Speed ..... 78 KIAS
  - Takeoff Ground Roll ..... 1203 FT
  - Dist. over 50' Obstacle ..... 1835 FT
- 

**Factors:**

The following factors are to be applied to the computed takeoff distance for the noted condition:

- Headwind - Subtract 10% from computed distance for each 12 knots headwind.
- Tailwind - Add 10% for each 2 knots tailwind up to 10 knots.
- Grass Runway - Add 15% to ground roll distance.
- Sloped Runway - Increase table distances by 22% of the ground roll distance at Sea Level, 30% of the ground roll distance at 5000 ft, 43% of the ground roll distance at 10,000 ft for each 1% of upslope. Decrease table distances by 7% of the ground roll distance at Sea Level, 10% of the ground roll distance at 5000 ft, and 14% of the ground roll distance at 10,000 ft for each 1% of downslope.

**• Caution •**

The above corrections for runway slope are required to be included herein. These corrections should be used with caution since published runway slope data is usually the net slope from one end of the runway to the other. Many runways will have portions of their length at greater or lesser slopes than the published slope, lengthening (or shortening) takeoff ground roll estimated from the table.

- If brakes are not held while applying power, distances apply from point where full throttle and mixture setting is complete.
- For operation in outside air temperatures colder than this table provides, use coldest data shown.
- For operation in outside air temperatures warmer than this table provides, use extreme caution.

# Takeoff Distance

PRESS ALT FT		DISTANCE FT	TEMPERATURE ~ °C					ISA
			0	10	20	30	40	
SL	Grnd Roll	910	982	1058	1137	1219	1020	
	50 ft	1414	1520	1629	1742	1860	1574	
1000	Grnd Roll	1003	1084	1167	1254	1344	1108	
	50 ft	1554	1670	1790	1915	2044	1706	
2000	Grnd Roll	1108	1196	1289	1385	1484	1206	
	50 ft	1710	1837	1970	2107	2248	1851	
3000	Grnd Roll	1224	1322	1424	1530	1640	1312	
	50 ft	1883	2024	2169	2320	2476	2010	
4000	Grnd Roll	1354	1463	1575	1693	1814	1430	
	50 ft	2076	2231	2392	2558	2730	2185	
5000	Grnd Roll	1500	1620	1746	1875	2009	1560	
	50 ft	2291	2462	2640	2823	3013	2377	
6000	Grnd Roll	1663	1796	1935	2078	2228	1704	
	50 ft	2532	2721	2917	3120	3330	2590	
7000	Grnd Roll	1846	1994	2147	2307	2473	1862	
	50 ft	2801	3010	3227	3452	3684	2824	
8000	Grnd Roll	2052	2216	2387	2564	2748	2038	
	50 ft	3103	3335	3575	3823	4080	3083	
9000	Grnd Roll	2284	2466	2656	2853	3058	2233	
	50 ft	3442	3698	3965	4240	4526	3370	
10000	Grnd Roll	2544	2748	2959	3179	3407	2449	
	50 ft	3822	4107	4403	4709	5026	3687	

Figure 5-9  
Sheet 1 of 2

## Takeoff Distance

<b>WEIGHT = 2900 LB</b> <b>Speed at Liftoff = 70 KIAS</b> <b>Speed over 50 Ft Obstacle = 74 KIAS</b> Flaps - 50% · Takeoff Pwr · Dry Paved		<b>Headwind:</b> Subtract 10% for each 12 knots headwind. <b>Tailwind:</b> Add 10% for each 2 knots tailwind up to 10 knots. <b>Runway Slope:</b> Ref. Factors. <b>Dry Grass:</b> Add 15% to Ground Roll					
PRESS ALT FT	DISTANCE FT	TEMPERATURE ~ °C					ISA
		0	10	20	30	40	
SL	Grnd Roll	605	654	704	757	811	679
	50 ft	958	1029	1103	1180	1259	1066
1000	Grnd Roll	668	721	777	835	895	738
	50 ft	1053	1131	1212	1297	1383	1155
2000	Grnd Roll	737	796	857	921	989	802
	50 ft	1158	1244	1334	1426	1522	1253
3000	Grnd Roll	815	880	948	1018	1092	873
	50 ft	1275	1370	1469	1570	1676	1361
4000	Grnd Roll	901	973	1048	1126	1207	952
	50 ft	1408	1510	1619	1731	1847	1479
5000	Grnd Roll	998	1078	1161	1248	1337	1088
	50 ft	1552	1667	1787	1911	2039	1610
6000	Grnd Roll	1107	1195	1287	1383	1483	1134
	50 ft	1714	1842	1974	2111	2253	1753
7000	Grnd Roll	1229	1327	1429	1535	1646	1239
	50 ft	1896	2037	2184	2335	2492	1912
8000	Grnd Roll	1366	1475	1588	1706	1829	1356
	50 ft	2100	2257	2419	2587	2760	2087
9000	Grnd Roll	1520	1641	1767	1899	2035	1486
	50 ft	2329	2503	2682	2868	3061	2281
10000	Grnd Roll	1683	1828	1969	2115	2267	1630
	50 ft	2586	2779	2978	3185	3399	2495

Figure 5-9  
Sheet 2 of 2

## Takeoff Climb Gradient

**Conditions:**

- Power ..... Full Throttle
- Mixture ..... Set per Placard
- Flaps ..... 50%
- Airspeed ..... Best Rate of Climb

**Example:**

Outside Air Temp ..... 20° C  
 Weight ..... 3400 LB  
 Pressure Altitude ..... 4000 FT

---

Climb Airspeed ..... 89 Knots  
 Gradient ..... 654 FT/NM

• Note •

- Climb Gradients shown are the gain in altitude for the horizontal distance traversed expressed as Feet per Nautical Mile.
- For operation in air colder than this table provides, use coldest data shown.
- For operation in air warmer than this table provides, use extreme caution.

Weight LB	Press Alt FT	Climb Speed KIAS	CLIMB GRADIENT ~ Feet per Nautical Mile				
			Temperature ~ °C				
			-20	0	20	40	ISA
3400	SL	91	939	896	853	811	864
	2000	90	834	793	75.2	711	770
	4000	89	734	694	654	615	680
	6000	88	638	600	561	524	594
	8000	87	546	509	472	436	510
	10000	86	458	422	387	353	431
2900	SL	91	1172	1122	1070	1019	1083
	2000	90	1049	1000	950	902	972
	4000	89	931	884	836	790	867
	6000	88	818	773	727	683	766
	8000	87	711	667	623	581	669
	10000	86	608	566	524	484	576

Figure 5-10

## Takeoff Rate of Climb

**Conditions:**

- Power.....Full Throttle
- Mixture.....Set per Placard
- Flaps..... 50%
- Airspeed .....Best Rate of Climb

**Example:**

Outside Air Temp ..... 10° C  
 Weight..... 3400 LB  
 Pressure Altitude..... 6000 FT

---

Climb Airspeed..... 88 Knots  
 Rate of Climb ..... 948 FPM

• Note •

- Rate-of-Climb values shown are change in altitude for unit time expended expressed in Feet per Minute.
- For operation in air colder than this table provides, use coldest data shown.
- For operation in air warmer than this table provides, use extreme caution.

Weight LB	Press Alt FT	Climb Speed KIAS	RATE OF CLIMB ~ Feet per Minute				
			Temperature ~ °C				
			-20	0	20	40	ISA
3400	SL	91	1326	1317	1300	1277	1304
	2000	90	1214	1200	1179	1153	1189
	4000	89	1100	1082	1057	1028	1074
	6000	88	985	962	934	901	958
	8000	87	869	842	809	774	843
	10000	86	851	719	683	644	727
2900	SL	91	1646	1638	1621	1598	1626
	2000	90	1518	1505	1484	1457	1494
	4000	89	1389	1371	1346	1316	1363
	6000	88	1259	1236	1207	1172	1232
	8000	87	1128	1100	1066	1028	1101
	10000	86	995	962	924	883	971

Figure 5-11

## Enroute Climb Gradient

**Conditions:**

- Power ..... Full Throttle
- Mixture ..... Full Rich
- Flaps ..... 0% (UP)
- Airspeed ..... Best Rate of Climb

**Example:**

Outside Air Temp ..... 20° C  
 Weight ..... 3400 LB  
 Pressure Altitude ..... 4000 FT

---

Climb Airspeed ..... 98 Knots  
 Gradient ..... 639 FT/NM

• Note •

- Climb Gradients shown are the gain in altitude for the horizontal distance traversed expressed as Feet per Nautical Mile.
- For operation in air colder than this table provides, use coldest data shown.
- For operation in air warmer than this table provides, use extreme caution.

Weight LB	Press Alt FT	Climb Speed KIAS	CLIMB GRADIENT - Feet per Nautical Mile				
			Temperature ~ °C				
			-20	0	20	40	ISA
3400	SL	101	911	867	823	781	834
	2000	100	813	771	729	689	748
	4000	98	720	679	639	600	665
	6000	97	630	590	552	515	584
	8000	96	544	505	468	433	507
	10000	95	461	424	388	354	433
	12000	94	381	346	312	279	361
	14000	93	304	271	238	207	292
16000	92	231	199	168	139	226	
2900	SL	101	1130	1078	1026	975	1039
	2000	100	1015	965	915	867	937
	4000	98	905	857	809	763	840
	6000	97	800	753	708	664	746
	8000	96	699	654	611	569	656
	10000	95	603	560	518	478	570
	12000	94	610	469	429	391	487
	14000	93	422	382	344	308	407
16000	92	337	299	263	229	331	

Figure 5-12

## Enroute Rate of Climb

**Conditions:**

- Power.....Full Throttle
- Mixture.....As Required
- Flaps.....0% (UP)
- Airspeed .....Best Rate of Climb

**Example:**

Outside Air Temp ..... 10° C  
 Weight..... 3400 LB  
 Pressure Altitude..... 6000 FT

---

Climb Airspeed..... 97 Knots  
 Rate of Climb ..... 1030 FPM

• Note •

- Rate-of-Climb values shown are change in altitude in feet per unit time expressed in Feet per Minute.
- For operation in air colder than this table provides, use coldest data shown.
- For operation in air warmer than this table provides, use extreme caution.

Weight  LB	Press Alt  FT	Climb Speed  KIAS	RATE OF CLIMB ~ Feet per Minute				
			Temperature ~ °C				
			-20	0	20	40	ISA
3400	SL	101	1428	1414	1392	1366	1398
	2000	100	1311	1292	1267	1238	1279
	4000	98	1193	1170	1141	1108	1160
	6000	97	1074	1046	1013	977	1041
	8000	96	953	921	884	845	922
	10000	95	830	794	754	712	803
	12000	94	706	666	623	577	684
	14000	93	581	537	490	441	565
2900	SL	101	1761	1748	1726	1698	1732
	2000	100	1629	1610	1584	1552	1596
	4000	98	1494	1471	1441	1405	1461
	6000	97	1359	1331	1296	1257	1326
	8000	96	1222	1189	1151	1108	1191
	10000	95	1084	1046	1004	958	1056
	12000	94	945	902	855	806	921
	14000	93	804	757	706	653	787
	16000	92	662	610	556	499	653

Figure 5-13



## Time, Fuel and Distance to Climb

**Conditions:**

- Power ..... Full Throttle
- Mixture ..... Lean for Best Power
- Fuel Density ..... 6.0 LB/GAL
- Weight ..... 3400 LB
- Winds ..... Zero
- Climb Airspeed ..... Noted

**Example:**

Outside Air Temp ..... ISA  
 Weight ..... 3400 LB  
 Airport Press ..... 1000 FT  
 Pressure Altitude ..... 12000 FT

---

Time to Climb ..... 11.3 Minutes  
 Fuel to Climb ..... 5.6 Gallon  
 Distance to Climb ..... 20.5 NM

**Factors:**

- Taxi Fuel - Add 1.5 gallon for start, taxi, and takeoff.
- Temperature - Add 10% to computed values for each 10° C above standard.

Press Alt FT	OAT (ISA) °C	Climb Speed KIAS	Rate Of Climb FPM	TIME, FUEL, DISTANCE ~ From Sea Level		
				Time Minutes	Fuel U.S. Gal	Distance NM
SL	15	101	1398	0.0	0.0	0.0
1000	13	100	1339	0.7	0.3	1.0
2000	11	100	1279	1.5	0.7	2.5
3000	9	99	1220	2.5	1.0	4.0
4000	7	98	1160	3.0	1.3	5.5
5000	5	97	1101	4.0	1.7	7.0
6000	3	97	1041	5.0	2.0	8.5
7000	1	96	982	6.0	2.4	10.5
8000	-1	96	922	7.0	2.7	12.0
9000	-3	95	863	8.0	3.1	14.5
10000	-5	95	803	9.5	3.5	16.5
11000	-7	94	744	10.5	3.9	19.0
12000	-9	94	684	12.0	4.4	21.5
13000	-11	93	625	13.5	4.8	24.5
14000	-13	93	565	15.0	5.3	28.0
15000	-15	92	506	17.0	5.8	31.5
16000	-17	92	446	19.0	6.4	35.5
17000	-19	91	387	21.5	7.1	40.0
17500	-20	91	357	24.0	7.8	45.5

Figure 5-14

## Cruise Performance

**Conditions:**

- Mixture.....Best Power
- Cruise Weight..... 2900 LB
- Winds..... Zero

**Example:**

Outside Air Temp ..... 29° C  
RPM ..... 2700 RPM  
Cruise Press Alt ..... 8000 FT

Note:  
Subtract 10 KTS if nose wheel fairings removed.

% Power (24.0 MAP)..... 75%  
True Airspeed..... 178 Knots  
Fuel Flow ..... 17.7 GPH

2000 Feet Pressure Altitude										
RPM	MAP	ISA - 30° C (-19° C)			ISA (11° C)			ISA + 30° C (41° C)		
		PWR	KTAS	GPH	PWR	KTAS	GPH	PWR	KTAS	GPH
2700	27.4	103%	186	24.6	98%	186	23.3	93%	181	22.0
2600	27.4	99%	183	23.5	94%	183	22.2	89%	178	21.5
2500	27.4	93%	179	22.1	88%	179	20.9	84%	174	20.8
2500	26.4	89%	176	21.1	84%	176	19.9	80%	171	20.2
2500	25.4	84%	173	20.0	80%	173	19.0	76%	168	19.5
2500	24.4	80%	170	19.0	76%	170	18.0	72%	165	18.8
2500	23.4	76%	167	18.0	72%	167	17.0	68%	162	18.1

4000 Feet Pressure Altitude										
RPM	MAP	ISA - 30° C (-23° C)			ISA (7° C)			ISA + 30° C (37° C)		
		PWR	KTAS	GPH	PWR	KTAS	GPH	PWR	KTAS	GPH
2700	25.4	96%	185	22.9	91%	185	21.6	87%	180	20.8
2600	25.4	92%	182	21.9	87%	182	20.7	83%	177	20.6
2500	25.4	87%	178	20.6	82%	178	19.5	78%	173	19.9
2500	24.4	82%	175	19.5	78%	175	18.5	74%	170	19.2
2500	23.4	78%	172	18.5	74%	172	17.5	70%	167	18.5
2500	22.4	73%	169	17.4	69%	169	16.5	66%	163	17.7
2500	21.4	69%	165	16.4	65%	165	15.5	62%	159	16.9

6000 Feet Pressure Altitude										
RPM	MAP	ISA - 30° C (-27° C)			ISA (3° C)			ISA + 30° C (33° C)		
		PWR	KTAS	GPH	PWR	KTAS	GPH	PWR	KTAS	GPH
2700	23.5	89%	184	21.2	85%	184	20.1	81%	179	19.6
2600	23.5	85%	181	20.3	81%	181	19.2	77%	176	19.1
2500	23.5	80%	177	19.1	76%	177	18.1	72%	172	18.3
2500	22.5	76%	174	18.1	72%	174	17.1	68%	169	17.6
2500	21.5	72%	170	17.0	68%	170	16.1	64%	165	16.9
2500	20.5	67%	166	15.9	64%	166	15.1	60%	161	16.1
2500	19.5	63%	162	14.9	59%	162	14.1	56%	157	15.3

Figure 5-15  
Sheet 1 of 3

## Cruise Performance

8000 Feet Pressure Altitude										
RPM	MAP	ISA - 30° C (-31° C)			ISA (-1° C)			ISA + 30° C (29° C)		
		PWR	KTAS	GPH	PWR	KTAS	GPH	PWR	KTAS	GPH
2700	21.7	83%	183	19.7	78%	183	18.6	75%	178	17.7
2600	21.7	79%	180	18.8	75%	180	17.8	71%	175	17.0
2500	21.7	75%	176	17.7	71%	176	16.8	67%	171	16.0
2500	20.7	70%	172	16.7	66%	172	15.8	63%	167	15.0
2500	19.7	66%	168	15.6	62%	168	14.8	59%	163	14.0
2500	18.7	61%	163	14.5	58%	163	13.8	55%	158	13.1
2500	17.7	57%	159	13.5	54%	159	12.8	51%	153	12.1

10,000 Feet Pressure Altitude										
RPM	MAP	ISA - 30° C (-35° C)			ISA (-5° C)			ISA + 30° C (25° C)		
		PWR	KTAS	GPH	PWR	KTAS	GPH	PWR	KTAS	GPH
2700	20.0	77%	182	18.2	73%	182	17.3	69%	176	16.4
2600	20.0	71%	177	17.0	68%	177	16.1	64%	172	15.3
2500	20.0	67%	173	16.0	64%	173	15.1	61%	167	14.4
2500	19.0	63%	168	14.9	59%	168	14.1	56%	163	13.4
2500	18.0	58%	163	13.8	55%	163	13.1	52%	158	12.5
2500	17.0	54%	158	12.8	51%	158	12.1	48%	153	11.5

12,000 Feet Pressure Altitude										
RPM	MAP	ISA - 30° C (-39° C)			ISA (-9° C)			ISA + 30° C (21° C)		
		PWR	KTAS	GPH	PWR	KTAS	GPH	PWR	KTAS	GPH
2700	18.5	71%	180	16.9	67%	180	16.0	64%	175	15.2
2600	18.5	68%	177	16.2	64%	177	15.3	61%	172	14.5
2500	18.5	64%	173	15.2	60%	173	14.4	58%	167	13.7
2500	17.5	59%	168	14.1	56%	168	13.4	53%	162	12.7
2500	16.5	55%	162	13.0	52%	162	12.3	49%	157	11.7
2500	15.5	50%	156	12.0	48%	156	11.3	45%	151	10.8

14,000 Feet Pressure Altitude										
RPM	MAP	ISA - 30° C (-43° C)			ISA (-13° C)			ISA + 30° C (17° C)		
		PWR	KTAS	GPH	PWR	KTAS	GPH	PWR	KTAS	GPH
2700	17.1	66%	178	15.6	62%	178	14.8	59%	173	14.1
2600	17.1	63%	175	14.9	60%	175	14.1	57%	170	13.5
2500	17.1	59%	171	14.1	56%	171	13.3	53%	165	12.7
2500	16.1	55%	165	13.0	52%	165	12.3	49%	159	11.7
2500	15.1	50%	159	11.9	47%	159	11.2	45%	153	10.7

Figure 5-15  
Sheet 2 of 3

## Cruise Performance

16,000 Feet Pressure Altitude										
RPM	MAP	ISA - 30° C (-47° C)			ISA (-17° C)			ISA + 30° C (13° C)		
		PWR	KTAS	GPH	PWR	KTAS	GPH	PWR	KTAS	GPH
2700	15.8	61%	176	14.5	58%	176	13.0	55%	171	13.0
2600	15.8	58%	173	13.8	55%	173	12.5	52%	167	12.5
2500	15.8	55%	168	13.0	52%	168	11.7	49%	163	11.7
2500	14.8	50%	162	11.9	47%	162	10.7	45%	156	10.7

17,000 Feet Pressure Altitude										
RPM	MAP	ISA - 30° C (-49° C)			ISA (-19° C)			ISA + 30° C (9° C)		
		PWR	KTAS	GPH	PWR	KTAS	GPH	PWR	KTAS	GPH
2700	15.2	59%	175	13.9	55%	175	13.2	53%	169	12.5
2600	15.2	56%	171	13.3	53%	171	12.6	50%	166	12.0
2500	15.2	53%	167	12.5	50%	167	11.9	47%	162	11.3
2500	14.2	48%	160	11.4	45%	160	10.8	43%	155	10.3

Figure 5-15  
Sheet 3 of 3

## Range / Endurance Profile

**Conditions:**

- Weight .....3400 LB
- Temperature ..... Standard Day
- Winds .....Zero
- Mixture ..... Best Economy
- Total Fuel.....81 Gallons

**Example:**

- Power Setting .....55%
- Takeoff Press Alt ..... 2000 FT
- Cruise Press Alt..... 6000 FT

---

- Fuel to Climb ..... 1.3 Gal.
- Cruise Fuel Flow ..... 11.3 GPH
- Endurance ..... 6.1 Hr
- Range..... 962 NM
- True Airspeed ..... 157 Knots

• Note •

- Fuel Remaining For Cruise is equal to 81.0 gallons usable, less climb fuel, less 9.8 gallons for 45 minutes IFR reserve fuel at 47% power (ISA @ 10,000 ft PA), less descent fuel, less fuel used prior to takeoff.
- Range and endurance shown includes descent to final destination at approximately 178 KIAS and 500 fpm
- Range is decreased by 1% if nose wheel fairings removed.

75% POWER					Mixture = Best Power		
Press Alt	Climb Fuel	Fuel Remaining For Cruise	Airspeed	Fuel Flow	Endurance	Range	Specific Range
FT	Gal	Gal	KTAS	GPH	Hours	NM	Nm/Gal
SL	0.0	70.8	166	17.8	4.0	661	9.3
2000	0.7	69.0	170	17.8	3.9	670	9.6
4000	1.3	67.2	173	17.8	3.9	680	9.8
6000	2.0	65.3	177	17.8	3.9	689	10.0
8000	2.7	63.5	180	17.8	3.8	700	10.3

**Figure 5-16**  
**Sheet 1 of 3**

## Range / Endurance Profile

<b>65% POWER</b>				<b>Mixture = Best Power</b>			
Press Alt	Climb Fuel	Fuel Remaining For Cruise	Airspeed	Fuel Flow	Endurance	Range	Specific Range
FT	Gal	Gal	KTAS	GPH	Hours	NM	Nm/Gal
SL	0.0	70.8	158	15.4	4.6	725	10.3
2000	0.7	69.0	161	15.4	4.5	735	10.5
4000	1.3	67.2	165	15.4	4.5	745	10.7
6000	2.0	65.3	168	15.4	4.5	755	11.0
8000	2.7	63.5	171	15.4	4.4	765	11.2
10000	3.5	61.6	174	15.4	4.4	775	11.5
12000	4.4	59.8	178	15.4	4.3	785	11.8

<b>55% POWER</b>				<b>Mixture = Best Power</b>			
Press Alt	Climb Fuel	Fuel Remaining For Cruise	Airspeed	Fuel Flow	Endurance	Range	Specific Range
FT	Gal	Gal	KTAS	GPH	Hours	NM	Nm/Gal
SL	0.0	70.8	149	13.1	5.4	806	11.4
2000	0.7	69.0	152	13.1	5.4	815	11.6
4000	1.3	67.2	154	13.1	5.3	825	11.9
6000	2.0	65.3	157	13.1	5.3	835	12.2
8000	2.7	63.5	160	13.1	5.2	845	12.4
10000	3.5	61.6	163	13.1	5.1	856	12.7
12000	4.4	59.8	166	13.1	5.1	865	13.0
14000	5.3	57.8	169	13.1	5.0	875	13.4

Figure 5-16  
Sheet 2 of 3

## Range / Endurance Profile

<b>55% POWER</b>				<b>Mixture = Best Economy</b>			
<b>Press Alt</b>	<b>Climb Fuel</b>	<b>Fuel Remaining For Cruise</b>	<b>Airspeed</b>	<b>Fuel Flow</b>	<b>Endurance</b>	<b>Range</b>	<b>Specific Range</b>
<b>FT</b>	<b>Gal</b>	<b>Gal</b>	<b>KTAS</b>	<b>GPH</b>	<b>Hours</b>	<b>NM</b>	<b>Nm/Gal</b>
<b>SL</b>	<b>0.0</b>	70.8	149	11.3	6.2	930	13.1
<b>2000</b>	<b>0.7</b>	69.0	152	11.3	6.2	941	13.4
<b>4000</b>	<b>1.3</b>	67.2	154	11.3	6.1	951	13.7
<b>6000</b>	<b>2.0</b>	65.3	157	11.3	6.1	962	14.0
<b>8000</b>	<b>2.7</b>	63.5	160	11.3	6.0	974	14.3
<b>10000</b>	<b>3.5</b>	61.6	163	11.3	5.9	985	14.6
<b>12000</b>	<b>4.4</b>	59.8	166	11.3	5.9	995	15.0
<b>14000</b>	<b>5.3</b>	57.8	169	11.3	5.8	1006	15.4

**Figure 5-16**  
**Sheet 3 of 3**

## Balked Landing Climb Gradient

**Conditions:**

- Power.....Full Throttle
- Mixture.....Set per Placard
- Flaps..... 100% (DN)
- Climb Airspeed .....  $V_{REF}$

**Example:**

Outside Air Temp ..... 20° C  
 Weight..... 3400 LB  
 Pressure Altitude..... 4000 FT

---

Climb Airspeed..... 77 Knots  
 Rate of Climb ..... 633 FT/NM

• Note •

- Balked Landing Climb Gradients shown are the gain in altitude for the horizontal distance traversed expressed as Feet per Nautical Mile.
- For operation in air colder than this table provides, use coldest data shown.
- For operation in air warmer than this table provides, use extreme caution.
- This chart is required data for certification. However, significantly better performance can be achieved by climbing at Best Rate of Climb speeds shown with flaps down or following the Go-Around / Balked Landing procedure in Section 4.

Weight LB	Press Alt FT	Climb Speed KIAS	CLIMB GRADIENT ~ Feet/Nautical Mile					Best Rate of Climb KIAS
			Temperature ~ °C					
			-20	0	20	40	ISA	
3400	SL	77	834	835	823	803	827	80
	2000	77	750	744	728	704	736	80
	4000	77	666	654	633	604	648	78
	6000	77	581	564	537	504	560	78
	8000	77	496	472	440	402	473	77
	10000	77	409	379	341	296	387	77
2900	SL	77	1069	1070	1056	1032	1060	
	2000	77	969	962	942	914	953	
	4000	77	869	855	829	796	847	
	6000	77	789	747	716	677	743	
	8000	77	668	639	602	556	641	
	10000	77	565	529	484	432	639	

Figure 5-17



## Balked Landing Rate of Climb

**Conditions:**

- Power ..... Full Throttle
- Mixture ..... Set per Placard
- Flaps ..... 100% (DN)
- Climb Airspeed.....  $V_{REF}$

**Example:**

- Outside Air Temp.....20° C
- Weight ..... 3400 LB
- Pressure Altitude ..... 4000 FT

---

- Climb Airspeed .....77 Knots
- Rate of Climb.....878 FT/NM

• Note •

- Balked Landing Rate of Climb values shown are the full flaps change in altitude for unit time expended expressed in Feet per Minute.
- For operation in air colder than this table provides, use coldest data shown.
- For operation in air warmer than this table provides, use extreme caution.
- This chart is required data for certification. However, significantly better performance can be achieved by climbing at the Best Rate of Climb speeds shown with flaps down or following the Go-Around / Balked Landing procedure in Section 4

Weight LB	Press Alt FT	Climb Speed KIAS	RATE OF CLIMB - Feet per Minute					Best Rate of Climb KIAS
			Temperature ~ °C					
			-20	0	20	40	ISA	
3400	SL	77	996	1035	1057	1067	1053	80
	2000	77	930	959	972	971	966	80
	4000	77	858	876	878	867	878	79
	6000	77	779	784	775	752	784	78
	8000	77	691	683	660	623	684	77
	10000	77	593	571	532	478	578	77
2900	SL	77	1268	1318	1348	1363	1342	
	2000	77	1195	1233	1252	1255	1245	
	4000	77	1115	1140	1146	1137	1144	
	6000	77	1026	1037	1030	1007	1037	
	8000	77	927	923	900	861	923	
	10000	77	817	796	755	696	803	

Figure 5-18

## Landing Distance

**Conditions:**

- Winds..... Zero
- Runway..... Dry, Level, Paved
- Flaps..... 100%
- Power..... 3° Power Approach  
to 50 FT obstacle,  
then smooth reduction  
to IDLE

**Example:**

- Outside Air Temp ..... 10°C
  - Weight..... 3400 LB
  - Pressure Altitude..... 2000 FT
  - Headwind ..... Zero
- 
- Obstacle Speed ( $V_{REF}$ )..... 77 KIAS
  - Landing Ground Roll..... 1206 FT
  - Dist. over 50' Obstacle ..... 2415 FT

**Factors:**

The following factors are to be applied to the computed landing distance for the noted condition:

- Headwind - Subtract 10% from table distances for each 13 knots headwind.
- Tailwind - Add 10% to table distances for each 2 knots tailwind up to 10 knots.
- Dry Grass Runway - Add 40% of ground roll to table distances.
- Sloped Runway - Increase table distances by 27% of the ground roll distance for each 1% of downslope. Decrease table distances by 9% of the ground roll distance for each 1% of upslope.

**• Caution •**

The above corrections for runway slope are required to be included herein. These corrections should be used with caution since published runway slope data is usually the net slope from one end of the runway to the other. Many runways will have portions of their length at greater or lesser slopes than the published slope, lengthening (or shortening) landing ground roll estimated from the table.

- For operation in outside air temperatures colder than this table provides, use coldest data shown
- For operation in outside air temperatures warmer than this table provides, use extreme caution.

## Landing Distance

<b>WEIGHT = 3400 LB</b> <b>Speed over 50 Ft Obstacle = 77 KIAS</b> Flaps - 100% · Idle · Dry, Level Paved Surface		<b>Headwind:</b> Subtract 10% per each 13 knots headwind. <b>Tailwind:</b> Add 10% for each 2 knots tailwind up to 10 knots. <b>Runway Slope:</b> Ref. Factors. <b>Dry Grass:</b> Add 40% to Ground Roll					
<b>PRESS ALT FT</b>	<b>DISTANCE  FT</b>	<b>TEMPERATURE ~ °C</b>					<b>ISA</b>
		0	10	20	30	40	
<b>SL</b>	<b>Grnd Roll</b>	1082	1121	1161	1200	1240	1141
	<b>50 ft</b>	2244	2298	2352	2408	2464	2325
<b>1000</b>	<b>Grnd Roll</b>	1122	1163	1204	1245	1286	1175
	<b>50 ft</b>	2298	2355	2412	2470	2529	2372
<b>2000</b>	<b>Grnd Roll</b>	1163	1206	1248	1291	1334	1210
	<b>50 ft</b>	2356	2415	2476	2537	2598	2422
<b>3000</b>	<b>Grnd Roll</b>	1207	1251	1295	1339	1384	1247
	<b>50 ft</b>	2417	2479	2543	2607	2672	2473
<b>4000</b>	<b>Grnd Roll</b>	1252	1298	1344	1390	1436	1285
	<b>50 ft</b>	2481	2547	2614	2681	2749	2528
<b>5000</b>	<b>Grnd Roll</b>	1300	1348	1395	1443	1490	1324
	<b>50 ft</b>	2550	2619	2689	2759	2831	2585
<b>6000</b>	<b>Grnd Roll</b>	1350	1399	1449	1498	1547	1365
	<b>50 ft</b>	2622	2694	2768	2842	2917	2644
<b>7000</b>	<b>Grnd Roll</b>	1402	1453	1504	1556	1607	1408
	<b>50 ft</b>	2698	2775	2852	2930	3008	2707
<b>8000</b>	<b>Grnd Roll</b>	1456	1509	1563	1616	1669	1452
	<b>50 ft</b>	2779	2860	2941	3022	3105	2773
<b>9000</b>	<b>Grnd Roll</b>	1513	1569	1624	1679	1735	1497
	<b>50 ft</b>	2865	2949	3035	3121	3207	2841
<b>10000</b>	<b>Grnd Roll</b>	1573	1630	1688	1746	1803	1545
	<b>50 ft</b>	2956	3045	3134	3225	3316	2914

**Figure 5-19**

Intentionally Left Blank

# ***Section 6***

## ***Weight and Balance***

### **Table of Contents**

Introduction .....	6-3
Airplane Weighing Form .....	6-6
Airplane Weighing Procedures .....	6-7
Weight & Balance Record .....	6-10
Loading Instructions .....	6-12
Center of Gravity Limits .....	6-14
Weight & Balance Loading Form .....	6-15
Loading Data .....	6-16
Moment Limits .....	6-17
Equipment List .....	6-18

Intentionally Left Blank

## Introduction

This section describes the procedure for establishing the basic empty weight and moment of the airplane. Sample forms are provided for reference. Procedures for calculating the weight and moment for various operations are also provided. A comprehensive list of all equipment available for this airplane is included at the back of this section.

It should be noted that specific information regarding the weight, arm, moment, and installed equipment for this airplane as delivered from the factory can only be found in the plastic envelope carried in the back of this handbook.

It is the responsibility of the pilot to ensure that the airplane is loaded properly.

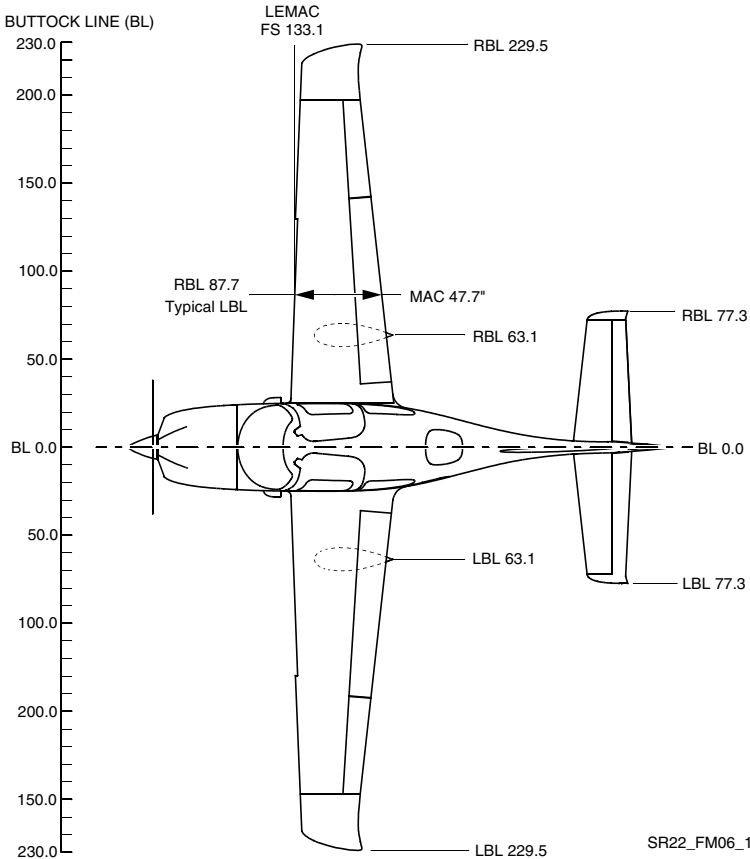
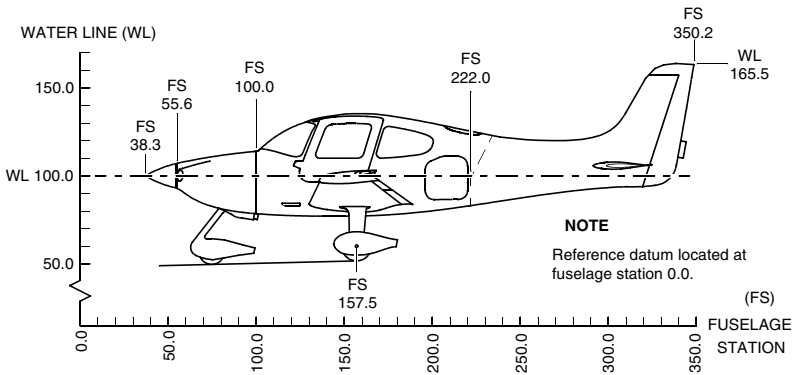

SR22\_FM06\_1439

**Figure 6-1**  
**Airplane Dimensional Data**



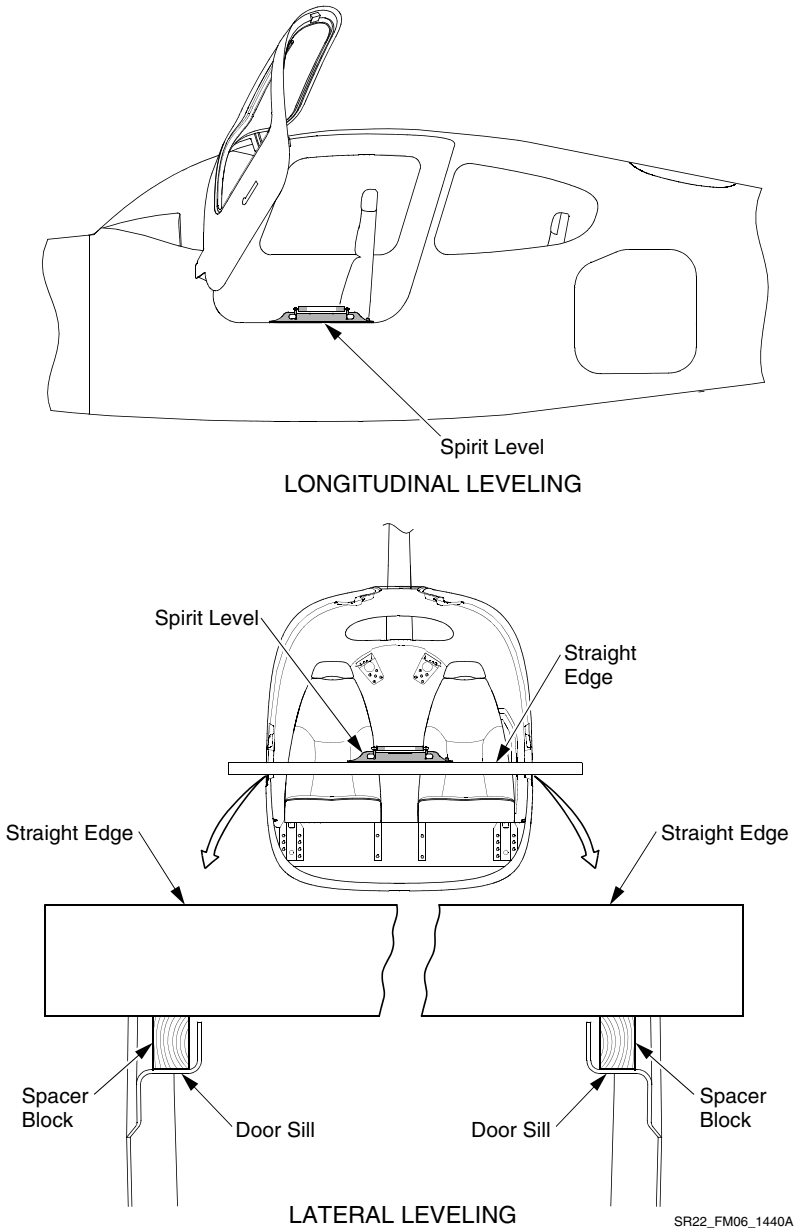

SR22\_FM06\_1440A

**Figure 6-2**  
**Airplane Leveling**

# Airplane Weighing Form

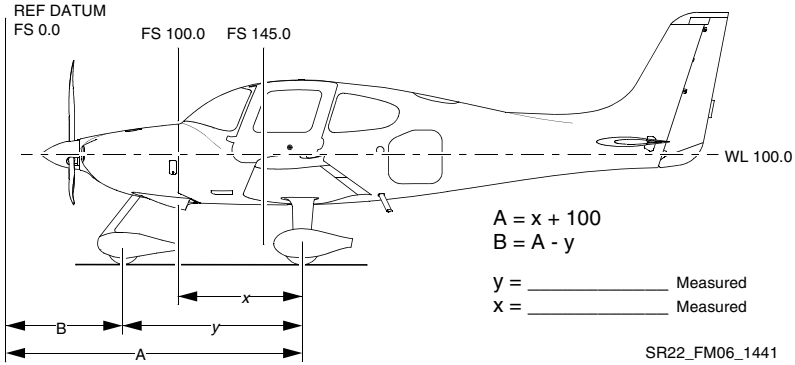

Weighing Point	Scale Reading	- Tare	= Net Weight	X Arm	= Moment
L Main				A=	
R Main				A=	
Nose				B=	
<b>Total As Weighed</b>				CG=	
<b>CG = Total Moment ÷ Total Weight</b>					
<i>Space below provided for additions or subtractions to as weighed condition</i>					
<b>Empty Weight</b>				CG=	
<b>Engine Oil (if oil drained)</b> <i>15 lb at FS 78.4, moment = 1176</i>					
Unusable Fuel			18.0	154.9	2788
Basic Empty Weight				CG=	

**Figure 6-3**  
**Airplane Weighing Form**

## Airplane Weighing Procedures

A basic empty weight and center of gravity were established for this airplane when the airplane was weighed just prior to initial delivery. However, major modifications, loss of records, addition or relocation of equipment, accomplishment of service bulletins, and weight gain over time may require re-weighing to keep the basic empty weight and center of gravity current. The frequency of weighing is determined by the operator. All changes to the basic empty weight and center of gravity are the responsibility of the operator. *Refer to Section 8 for specific servicing procedures.*

1. Preparation:
  - a. Inflate tires to recommended operating pressures.
  - b. Service brake reservoir.
  - c. Drain fuel system.
  - d. Service engine oil.
  - e. Move crew seats to the most forward position.
  - f. Raise flaps to the fully retracted position.
  - g. Place all control surfaces in neutral position.
  - h. Verify equipment installation and location by comparison to equipment list.
2. Leveling (Figure 6-2):
  - a. Level longitudinally with a spirit level placed on the pilot door sill and laterally with of a spirit level placed across the door sills. Alternately, level airplane by sighting the forward and aft tool holes along waterline 95.9.
  - b. Place scales under each wheel (minimum scale capacity, 500 pounds nose, 1000 pounds each main).
  - c. Deflate the nose tire and/or shim underneath scales as required to properly center the bubble in the level.
3. Weighing (Figure 6-3):
  - a. With the airplane level, doors closed, and brakes released, record the weight shown on each scale. Deduct the tare, if any, from each reading.

4. Measuring (Figure 6-3):
  - a. Obtain measurement 'x' by measuring horizontally along the airplane center line (BL 0) from a line stretched between the main wheel centers to a plumb bob dropped from the forward side of the firewall (FS 100). Add 100 to this measurement to obtain left and right weighing point arm (dimension 'A'). Typically, dimension 'A' will be in the neighborhood of 157.5.
  - b. Obtain measurement 'y' by measuring horizontally and parallel to the airplane centerline (BL 0), from center of nosewheel axle, left side, to a plumb bob dropped from the line stretched between the main wheel centers. Repeat on right side and average the measurements. Subtract this measurement from dimension 'A' to obtain the nosewheel weighing point arm (dimension 'B').
5. Determine and record the moment for each of the main and nose gear weighing points using the following formula:

$$\text{Moment} = \text{Net Weight} \times \text{Arm}$$

6. Calculate and record the as-weighed weight and moment by totaling the appropriate columns.
7. Determine and record the as-weighed C.G. in inches aft of datum using the following formula:

$$\text{C.G.} = \text{Total Moment} \div \text{Total Weight}$$

8. Add or subtract any items not included in the as-weighed condition to determine the empty condition. Application of the above C.G. formula will determine the C.G. for this condition.
9. Add the correction for engine oil (15 lb at FS 78.4), if the airplane was weighed with oil drained. Add the correction for unusable fuel (18.0 lb at FS 154.9) to determine the Basic Empty Weight and Moment. Calculate and record the Basic Empty Weight C.G. by applying the above C.G. formula.
10. Record the new weight and C.G. values on the Weight and Balance Record (Figure 6-4).

The above procedure determines the airplane Basic Empty Weight, moment, and center of gravity in inches aft of datum. C.G. can also be expressed in terms of its location as a percentage of the airplane Mean Aerodynamic Cord (MAC) using the following formula:

$$C.G. \% MAC = 100 \times (C.G. \text{ Inches} - LEMAC) \div MAC$$

Where:

$$LEMAC = 132.9$$

$$MAC = 48.4$$

## Weight & Balance Record

Use this form to maintain a continuous history of changes and modifications to airplane structure or equipment affecting weight and balance:

Serial Num:			Reg. Num:			Page of		
Date	Item No.		Description of Article or Modification	Weight Change Added (+) or Removed (-)			Running Basic Empty Weight	
	In	Out		WT LB	ARM IN.	MOM/ 1000	WT LB	MOM/ 1000
			As Delivered					

**Figure 6-4**  
**Weight and Balance Record**

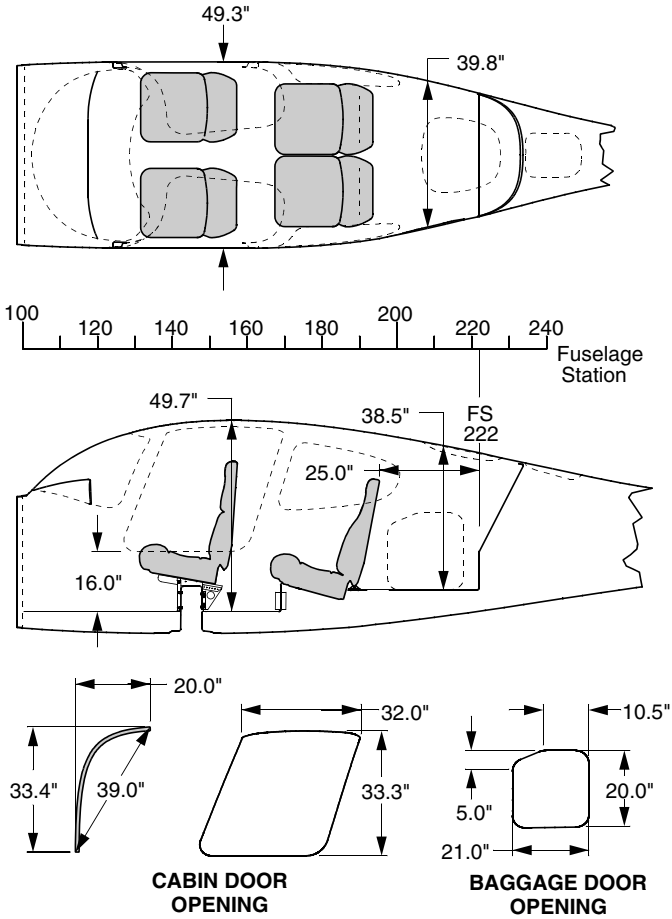

SR22 FM06 1019

Location	Length	Width	Height	Volume
Cabin	122"	49.3"	49.7	137 cu ft
Baggage Compartment	36"	39.8"	38.5"	32 cu ft

**Figure 6-5**  
**Airplane Interior Dimensions**

## Loading Instructions

It is the responsibility of the pilot to ensure that the airplane is properly loaded and operated within the prescribed weight and center of gravity limits. The following information enables the pilot to calculate the total weight and moment for the loading. The calculated moment is then compared to the Moment Limits chart or table (Figure 6-9) for a determination of proper loading.

Airplane loading determinations are calculated using the Weight & Balance Loading Form (Figure 6-7), the Loading Data chart and table (Figure 6-8), and the Moment Limits chart and table (Figure 6-9).

1. **Basic Empty Weight** – Enter the current Basic Empty Weight and Moment from the Weight & Balance Record (Figure 6-4).
2. **Front Seat Occupants** – Enter the total weight and moment/1000 for the front seat occupants from the Loading Data (Figure 6-8).
3. **Rear Seat Occupants** – Enter the total weight and moment/1000 for the rear seat occupants from the Loading Data (Figure 6-8).
4. **Baggage** – Enter weight and moment for the baggage from the Loading Data (Figure 6-8).
  - If desired, subtotal the weights and moment/1000 from steps 1 through 4. This is the *Zero Fuel Condition*. It includes all useful load items excluding fuel.
5. **Fuel Loading** – Enter the weight and moment of usable fuel loaded on the airplane from the Loading Data (Figure 6-8).
  - Subtotal the weight and moment/1000. This is the *Ramp Condition* or the weight and moment of the aircraft before taxi.
6. **Fuel for start, taxi, and runup** – This value is pre-entered on the form. Normally, fuel used for start, taxi, and runup is approximately 9 pounds at an average moment/1000 of 1.394.
7. **Takeoff Condition** – Subtract the weight and moment/1000 for step 8 (start, taxi, and runup) from the Ramp Condition values (step 7) to determine the Takeoff Condition weight and moment/1000.
  - The total weight at takeoff must not exceed the maximum weight limit of 3400 pounds.



- The total moment/1000 must not be above the maximum or below the minimum moment/1000 for the *Takeoff Condition Weight* as determined from the Moment Limits chart or table (Figure 6-9).

## Center of Gravity Limits

The charts below depict the airplane center-of-gravity envelope in terms of inches aft of the reference datum and as a percentage of the Mean Aerodynamic Cord (MAC). The relationship between the two is detailed in the weighing instructions.

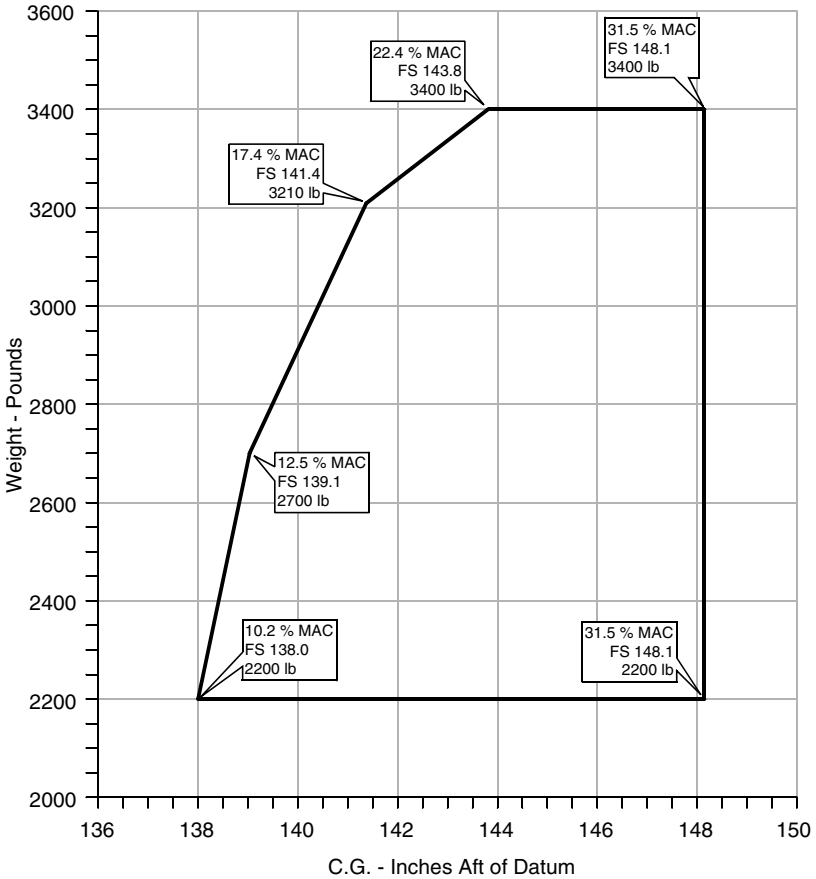

SR22\_FM02\_1945

**Figure 6-6**  
**Center of Gravity Limits**

# Weight & Balance Loading Form

Serial Num: \_\_\_\_\_ Date: \_\_\_\_\_

Reg. Num: \_\_\_\_\_ Initials: \_\_\_\_\_

Item	Description	Weight LB	Moment/ 1000
1.	<b>Basic Empty Weight</b> <i>Includes unusable fuel &amp; full oil</i>		
2.	Front Seat Occupants <i>Pilot &amp; Passenger (total)</i>		
3.	Rear Seat Occupants		
4.	Baggage Area <i>130 lb maximum</i>		
5.	<b>Zero Fuel Condition Weight</b> <i>Sub total item 1 thru 4</i>		
6.	Fuel Loading <i>81 Gallon @ 6.0 lb/gal. Maximum</i>		
7.	<b>Ramp Condition Weight</b> <i>Sub total item 5 and 6</i>		
8.	Fuel for start, taxi, and runup <i>Normally 9 lb at average moment of 1394.</i>	-	-
9.	<b>Takeoff Condition Weight</b> <i>Subtract item 8 from item 7</i>		

• Note •

The Takeoff Condition Weight must not exceed 3400 lb.

The Takeoff Condition Moment must be within the Minimum Moment to Maximum Moment range at the Takeoff Condition Weight. (Refer to Figure 6-9, Moment Limits).

**Figure 6-7**  
**Weight and Balance Loading Form**

# Loading Data

Use the following chart or table to determine the moment/1000 for fuel and payload items to complete the Loading Form (Figure 6-7).

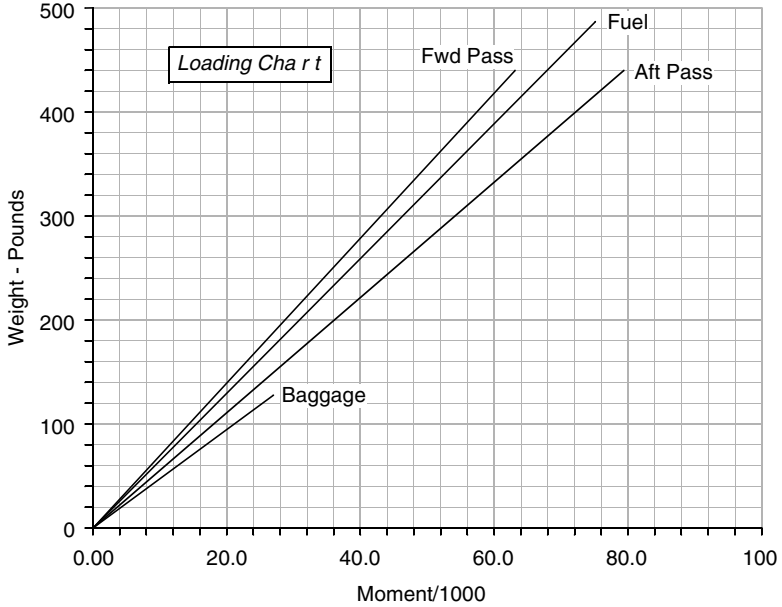

Weight LB	Fwd Pass FS 143.5	Aft Pass FS 180.0	Baggage FS 208.0	Fuel FS 154.9	Weight LB	Fwd Pass FS 143.5	Aft Pass FS 180.0	Fuel FS 154.9
20	2.87	3.60	4.16	3.10	260	37.31	46.80	40.27
40	5.74	7.20	8.32	6.20	280	40.18	50.40	43.37
60	8.61	10.80	12.48	9.29	300	43.05	54.00	46.47
80	11.48	14.40	16.64	12.39	320	45.92	57.60	49.57
100	14.35	18.00	20.80	15.49	340	48.79	61.20	52.67
120	17.22	21.60	24.96	18.59	360	51.66	64.80	55.76
140	20.09	25.20	(27.04)*	21.69	380	54.53	68.40	58.86
160	22.96	28.80		24.78	400	57.40	72.00	61.96
180	25.83	32.40		27.88	420	60.27	75.60	65.06
200	28.70	36.00		30.98	440	63.14	79.20	68.16
220	31.57	39.60		34.08	460			71.25
240	34.44	43.20		37.18	486**			75.28

\*130 lb Maximum

\*\*81 U.S. Gallons Usable

**Figure 6-8**  
**Loading Data**

# Moment Limits

Use the following chart or table to determine if the weight and moment from the completed Weight and Balance Loading Form (Figure 6-7) are within limits.

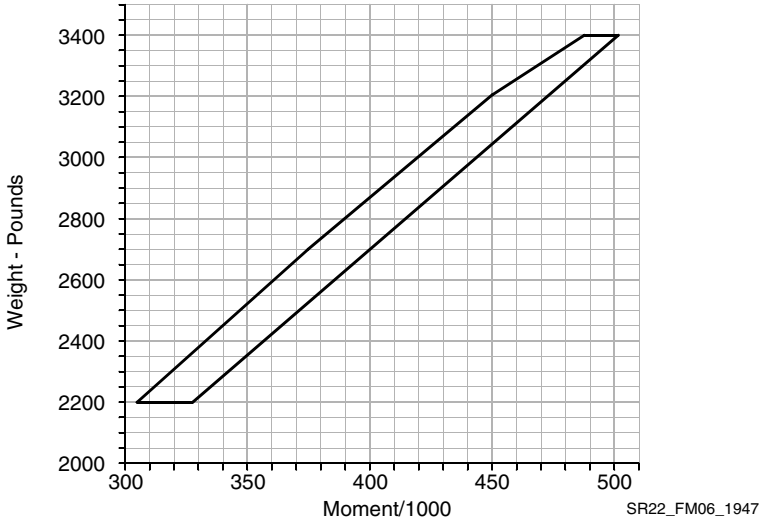

Weight LB	Moment/1000		Weight LB	Moment/1000	
	Minimum	Maximum		Minimum	Maximum
2200	304	326	2850	398	422
2250	311	333	2900	406	430
2300	318	341	2950	414	437
2350	326	348	3000	421	444
2400	333	355	3050	429	452
2450	340	363	3100	437	459
2500	347	370	3150	444	467
2550	354	378	3200	452	474
2600	362	385	3250	461	481
2650	369	392	3300	471	489
2700	375	400	3350	480	496
2750	383	407	3400	489	504
2800	390	415			

**Figure 6-9**  
**Moment Limits**

## **Equipment List**

This list will be determined after the final equipment has been installed in the aircraft.

# **Section 7**

## ***Airplane and Systems Description***

### **Table of Contents**

Introduction .....	7-5
Airframe .....	7-6
Fuselage .....	7-6
Wings .....	7-6
Empennage .....	7-7
Wing Flaps .....	7-8
Flap Control Switch.....	7-8
Primary Flight Controls .....	7-10
Elevator System.....	7-10
Aileron System.....	7-12
Rudder System .....	7-14
Trim Systems .....	7-16
Pitch Trim Control System.....	7-16
Roll Trim Control System.....	7-16
Yaw Trim System.....	7-17
Flight Deck Arrangement .....	7-18
Instrument Panel.....	7-18
Center Console.....	7-19
Airplane Cabin .....	7-22
Cabin Doors.....	7-22
Windshield and Windows.....	7-22
Baggage Compartment.....	7-22
Seats.....	7-24
Cabin Safety Equipment .....	7-26
Landing Gear .....	7-28
Main Gear .....	7-28
Nose Gear .....	7-28
Brake System .....	7-28
Engine .....	7-31
Engine Oil System .....	7-31
Engine Cooling .....	7-32
Engine Fuel Injection .....	7-32
Engine Air Induction System.....	7-32

Engine Fuel Ignition ..... 7-32

Engine Exhaust ..... 7-33

Engine Controls ..... 7-33

Alternate Air Control ..... 7-34

Engine Indicating ..... 7-34

Propeller ..... 7-38

Fuel System ..... 7-39

    Fuel Caution Light ..... 7-41

    Fuel Quantity Indicator ..... 7-41

    Fuel Selector Valve ..... 7-42

    Boost Pump Switch ..... 7-42

Electrical System ..... 7-43

    Power Generation ..... 7-43

    Power Distribution ..... 7-46

    BAT & ALT Master Switches ..... 7-46

    Avionics Power Switch ..... 7-47

    Low-Volts Warning Light ..... 7-47

    Volt / Amp Meter ..... 7-48

    ALT Fail Caution Lights ..... 7-48

    Circuit Breakers and Fuses ..... 7-49

    Ground Service Receptacle ..... 7-50

    Convenience Outlet ..... 7-50

Exterior Lighting ..... 7-51

    Navigation Lights ..... 7-51

    Strobe Light ..... 7-51

    Landing Light ..... 7-51

Interior Lighting ..... 7-52

    Instrument Lights ..... 7-52

    Panel Flood Lights ..... 7-52

    Reading Lights ..... 7-52

    Overhead Dome Light ..... 7-52

Environmental System ..... 7-53

    Cabin Heat Control ..... 7-55

    Cabin Cooling Control ..... 7-55

    Cabin Air Selector ..... 7-55

Stall Warning System ..... 7-56

Pitot-Static System ..... 7-58

    Airspeed Indicator ..... 7-58

    Vertical Speed Indicator ..... 7-58



Altimeter.....	7-59
Pitot Heat Switch .....	7-59
Pitot Heat Light .....	7-60
Alternate Static Source .....	7-60
Avionics and Navigation.....	7-61
Avionics Power Switch.....	7-62
Magnetic Compass .....	7-62
Turn Coordinator.....	7-63
Attitude Indicator .....	7-63
Course Deviation Indicator .....	7-64
Horizontal Situation Indicator.....	7-64
Autopilot.....	7-67
Audio System.....	7-69
Multi-Function Display .....	7-70
GPS Navigation .....	7-71
Communication (COM) Transceivers .....	7-73
Navigation (Nav) Receiver.....	7-74
Transponder .....	7-75
Emergency Locator Transmitter .....	7-76
Hour Meter.....	7-77
Digital Clock.....	7-77
Cirrus Airplane Parachute System.....	7-80
System Description.....	7-80
Activation Handle.....	7-81
Deployment Characteristics.....	7-82

Intentionally Left Blank

## Introduction

This section provides a basic description and operation of the standard airplane and its systems. Optional equipment described within this section is identified as optional.

• Note •

Some optional equipment, primarily avionics, may not be described in this section. For description and operation of optional equipment not described in this section, *refer to Section 9, Supplements*

## Airframe

### Fuselage

The SR22 monocoque fuselage is constructed primarily of composite materials and is designed to be aerodynamically efficient. The cabin area is bounded on the forward side by the firewall at fuselage station 100, and on the rear by the aft baggage compartment bulkhead at fuselage station 222. Comfortable seating is provided for four adults. A composite roll cage within the fuselage structure provides roll protection for the cabin occupants. The cabin and baggage compartment floors are constructed of a foam core composite with access to under-floor components.

All flight and static loads are transferred to the fuselage structure from the wings and control surfaces through four wing attach points in two locations under the front seats and two locations on the sidewall just aft of the rear seats.

*Serials 0795, 0820 and subsequent:* The lower firewall employs a 20° bevel to improve crashworthiness. In addition, an avionics bay is located aft of bulkhead 222 and accessible through an access panel installed on the RH side of the aft fuselage.

- Note •

*Refer to Airplane Cabin description* in this section for a complete description of doors, windows, baggage compartment, seats, and safety equipment.

### Wings

The wing structure is constructed of composite materials producing wing surfaces that are smooth and seamless. The wing cross section is a blend of several high performance airfoils. A high aspect ratio results in low drag. Each wing provides attach structure for the main landing gear and contains a 42-gallon fuel tank.

The wing is constructed in a conventional spar, rib, and shear section arrangement. The upper and lower skins are bonded to the spar, ribs, and shear sections (rear spars) forming a torsion box that carries all of the wing bending and torsion loads. The wing spar is manufactured in one piece and is continuous from wing tip to wing tip. The shear webs (rear spars) are similar in construction but do not carry through the

fuselage. The main wing spar passes under the fuselage below the two front seats and attaches to the fuselage at two locations. The rear shear webs are attached to the fuselage sidewalls just aft of the rear seats.

## **Empennage**

The empennage consists of a horizontal stabilizer, a two-piece elevator, a vertical fin and a rudder. All of the empennage components are conventional spar (shear web), rib, and skin construction.

The horizontal stabilizer is a single composite structure from tip to tip. The two-piece elevator, attached to the horizontal stabilizer, is aluminum.

The vertical stabilizer is composite structure integral to the main fuselage shell for smooth transfer of flight loads. The rudder is aluminum and is attached to the vertical stabilizer rear shear web at three hinge points.

## Wing Flaps

The electrically controlled, single-slotted flaps provide low-speed lift enhancement. Each flap is connected to the wing structure at three hinge points. The flaps are selectively set to three positions: 0%, 50% (16°) and 100% (32°) by operating the FLAP control switch. The FLAP control switch positions the flaps through a motorized linear actuator mechanically connected to both flaps by a torque tube. Proximity switches in the actuator limit flap travel to the selected position and provide position indication. The wing flaps and control circuits are powered by 28 VDC through the 15 amp FLAPS circuit breaker on the Non-Essential Bus.

### Flap Control Switch

An airfoil-shaped FLAPS control switch is located at the bottom of the vertical section of the center console. The control switch is marked and has detents at three positions: UP (0%), 50% and 100% (Down). The appropriate  $V_{FE}$  speed is marked at the Flap 50% and 100% switch positions. Setting the switch to the desired position will cause the flaps to extend or retract to the appropriate setting. An indicator light at each control switch position illuminates when the flaps reach the selected position. The UP (0%) light is green and the 50% and FULL (100%) lights are yellow.

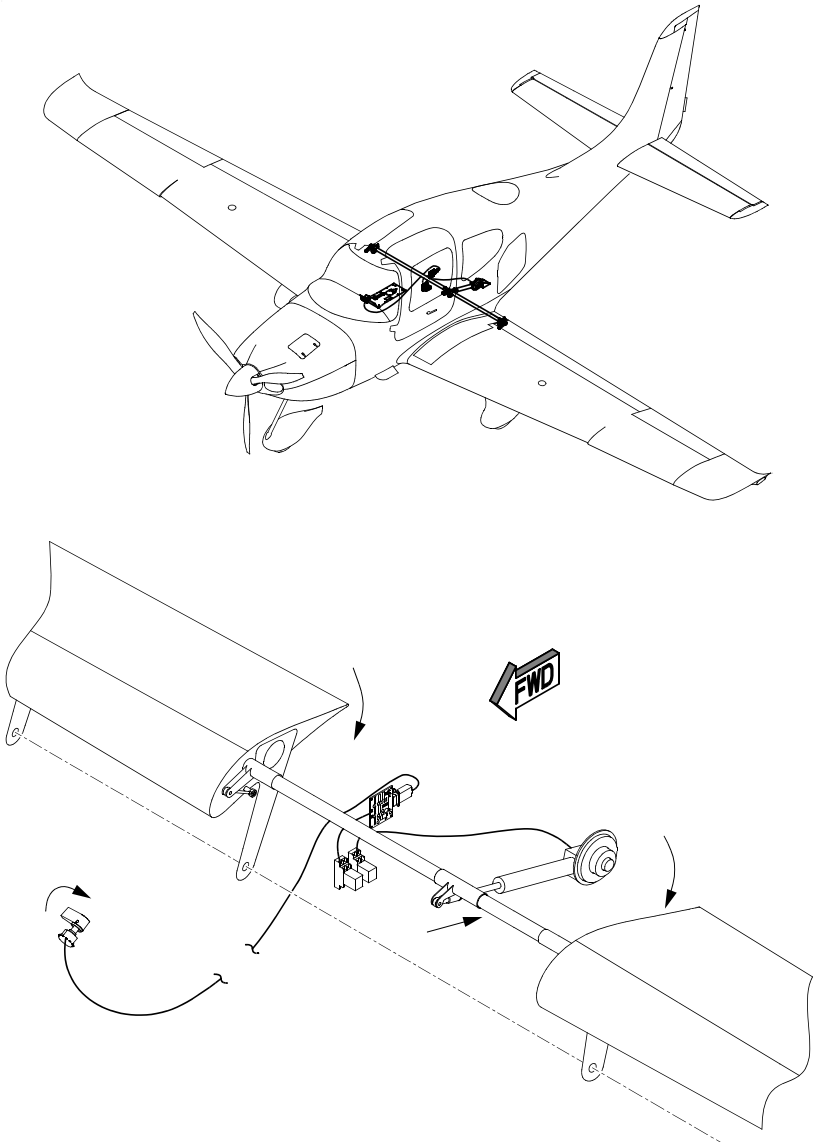

SR22\_FM07\_1460

**Figure 7-1**  
**Flap Control System**

## Primary Flight Controls

The SR22 uses conventional flight controls for ailerons, elevator and rudder. The control surfaces are pilot controlled through either of two single-handed side control yokes mounted beneath the instrument panel. The location and design of the control yokes allow easy, natural use by the pilot. The control system uses a combination of push rods, cables and bell cranks for control of the surfaces.

Roll trim and pitch trim are available through an electric button on the top of each control yoke. Electric yaw trim, if installed, is accomplished by operating a switch on the forward console immediately to the left of the Flaps switch.

### Elevator System

The two-piece elevator provides airplane pitch control. The elevator is of conventional design with skin, spar and ribs manufactured of aluminum. Each elevator half is attached to the horizontal stabilizer at two hinge points and to the fuselage tailcone at the elevator control sector.

Elevator motion is generated through the pilot's control yokes by sliding the yoke tubes forward or aft in a bearing carriage. A push-pull linkage is connected to a cable sector mounted on a torque tube. A single cable system runs from the forward elevator sector under the cabin floor to the aft elevator sector pulley. A push-pull tube connected to the aft elevator sector pulley transmits motion to the elevator bellcrank attached to the elevators.



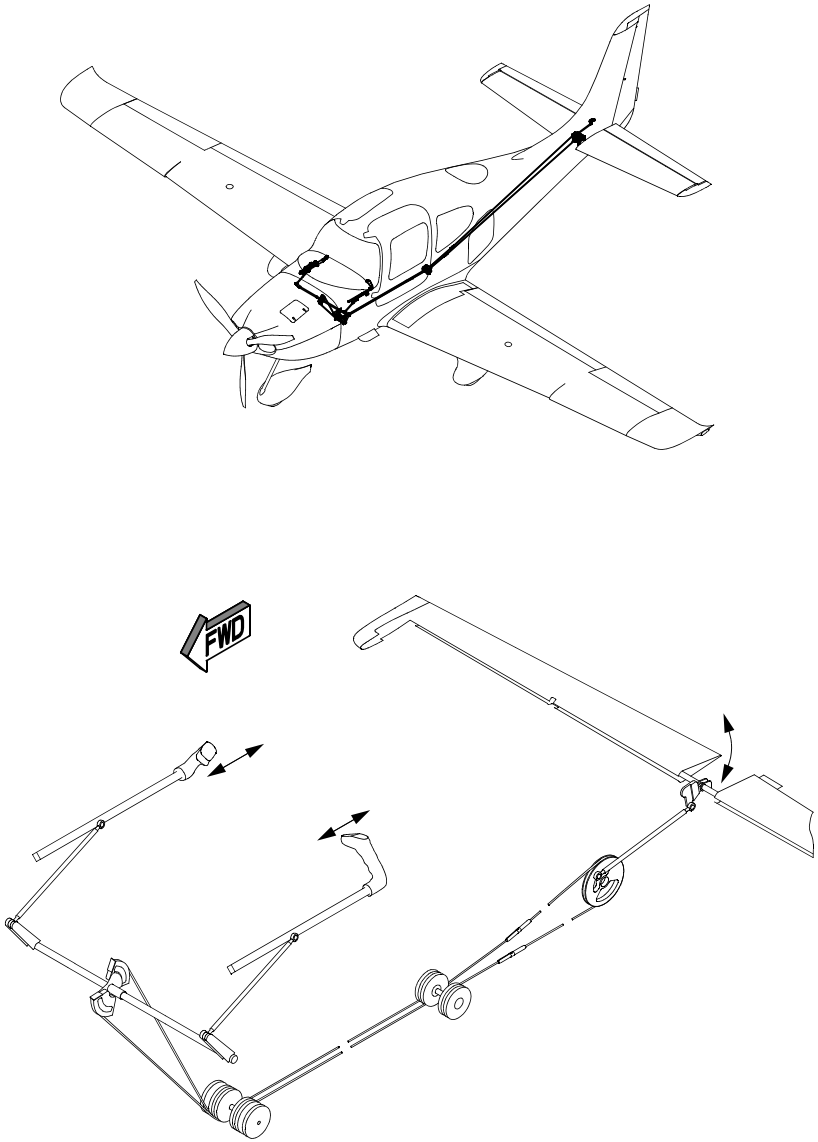

SR22\_FM07\_1461

**Figure 7-2**  
**Elevator Control System**

## **Aileron System**

The ailerons provide airplane roll control. The ailerons are of conventional design with skin, spar and ribs manufactured of aluminum. Each aileron is attached to the wing shear web at two hinge points.

Aileron control motion is generated through the pilot's control yokes by rotating the yokes in pivoting bearing carriages. Push rods link the pivoting carriages to a centrally located pulley sector. A single cable system runs from the sector to beneath the cabin floor and aft of the rear spar. From there, the cables are routed in each wing to a vertical sector/crank arm that rotates the aileron through a right angle conical drive arm.

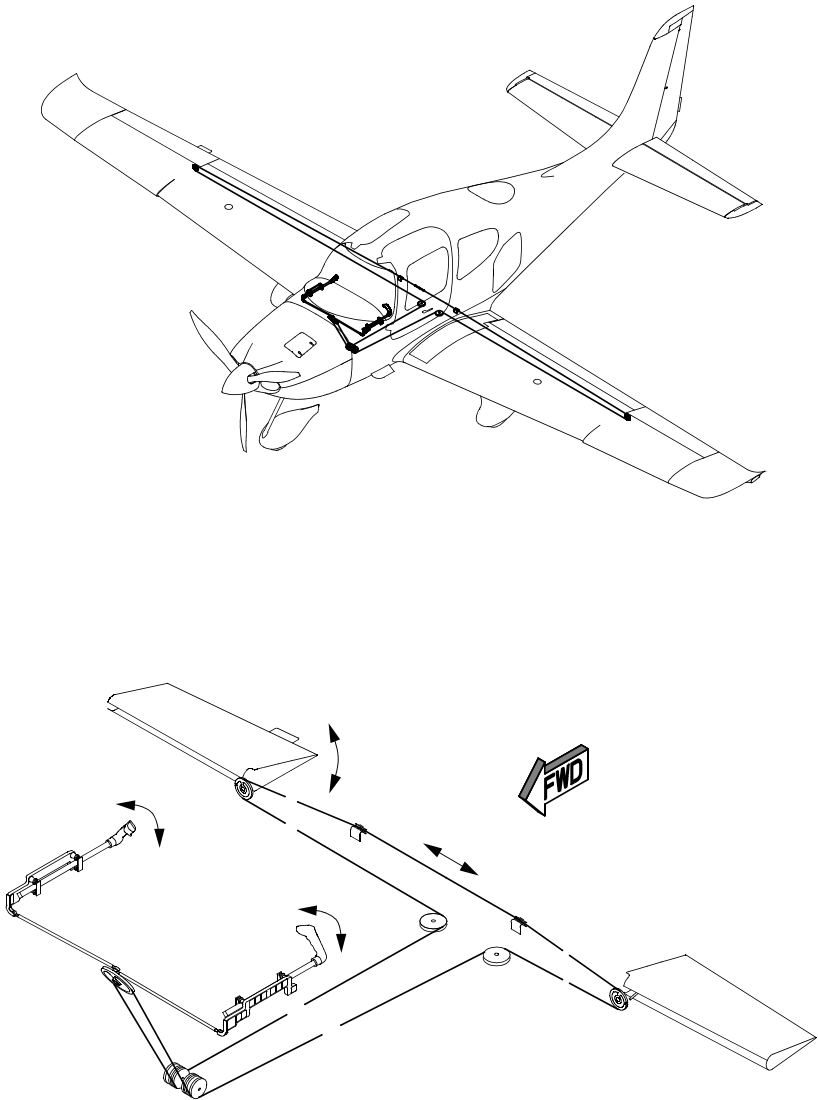

SR22\_FM07\_1462

**Figure 7-3**  
**Aileron Control System**

## Rudder System

The rudder provides airplane directional (yaw) control. The rudder is of conventional design with skin, spar and ribs manufactured of aluminum. The rudder is attached to the aft vertical stabilizer shear web at three hinge points and to the fuselage tailcone at the rudder control bell crank.

Rudder motion is transferred from the rudder pedals to the rudder by a single cable system under the cabin floor to a sector next to the elevator sector pulley in the aft fuselage. A push-pull tube from the sector to the rudder bell crank translates cable motion to the rudder. Springs and a ground adjustable spring cartridge connected to the rudder pedal assembly tension the cables and provide centering force.

A rudder-aileron interconnect is installed to provide a maximum of 5° down aileron with full rudder deflection. Right rudder input will cause right roll input and left rudder input will cause left roll input. With neutral aileron trim, aileron inputs will not cause rudder deflection.

On some airplanes, an electrically operated trim tab on the trailing edge of the rudder allows pilot-operated rudder trim. Airplanes without electric rudder trim have a ground adjustable trim tab installed.

### **Control Locks**

The Cirrus SR22 control system is not equipped with gust locks. The trim spring cartridges have sufficient power to act as a gust damper without rigidly locking the position.

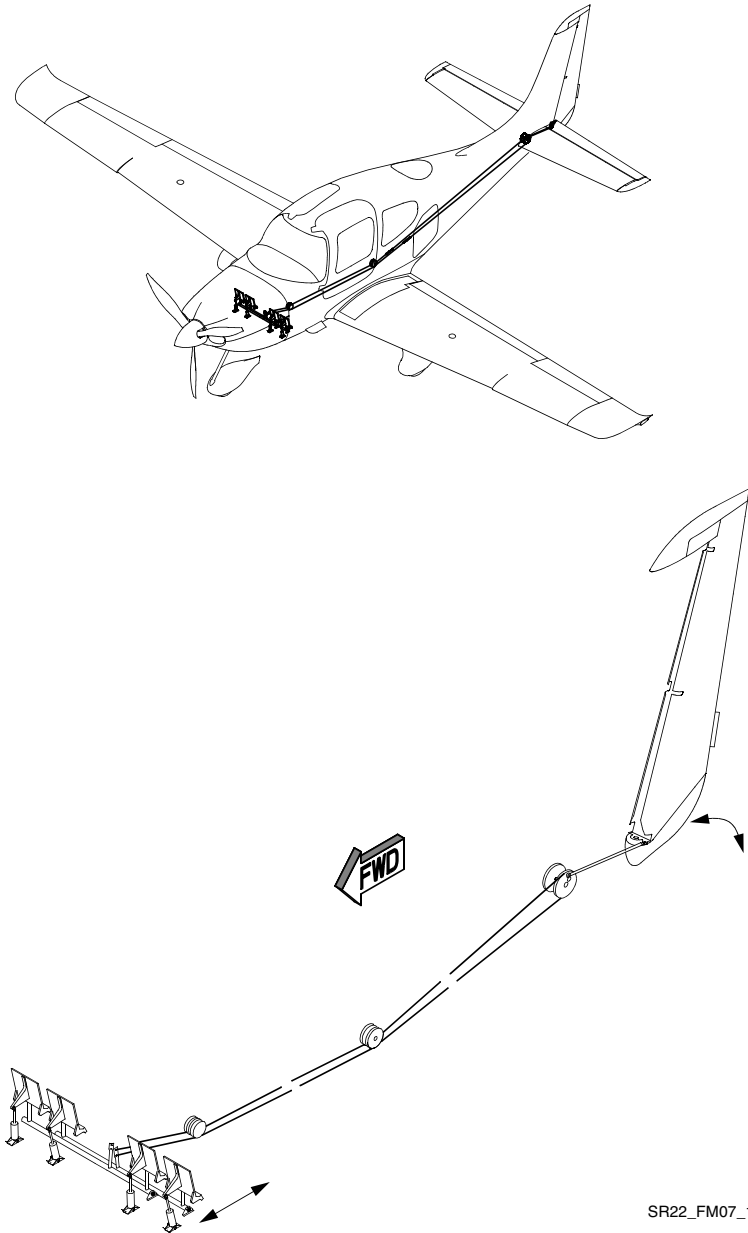

SR22\_FM07\_1463

**Figure 7-4**  
**Rudder Control System**

## Trim Systems

Roll and pitch trim are provided by adjusting the neutral position of a compression spring cartridge in each control system by means of an electric motor. The electric roll trim is also used by the autopilot to position the ailerons. An electrically actuated trim tab on the rudder, if installed, provides rudder trim. It is possible to easily override full trim or autopilot inputs by using normal control inputs.

Ground adjustable trim tabs are installed on the elevator and right aileron to provide small adjustments in neutral trim. On airplanes without electric rudder trim, a ground adjustable trim tab is installed on the rudder. These tabs are factory set and do not normally require adjustment.

### Pitch Trim Control System

An electric motor changes the neutral position of the spring cartridge attached to the elevator control horn. A conical trim button located on top of each control yoke controls the motor. Moving the switch forward will initiate nose-down trim and moving the switch aft will initiate nose-up trim. Pressing down on the switch will disconnect the autopilot if the autopilot was engaged. Neutral (takeoff) trim is indicated by the alignment of a reference mark on the yoke tube with a tab attached to the instrument panel bolster. The elevator trim also provides a secondary means of aircraft pitch control in the event of a failure in the primary pitch control system not involving a jammed elevator. Elevator (pitch) trim operates on 28 VDC supplied through the 2-amp PITCH / YAW TRIM circuit breaker on Main Bus 1.

### Roll Trim Control System

An electric motor changes the neutral position of a spring cartridge attached to the left actuation pulley in the wing. A conical trim button located on top of each control yoke controls the motor. Moving the switch left will initiate left-wing-down trim and moving the switch right will initiate right-wing-down trim. Pressing down on the switch will disconnect the autopilot if the autopilot was engaged. Neutral trim is indicated by the alignment of the line etched on the control yoke with the centering indication marked on the instrument panel. The aileron trim also provides a secondary means of aircraft roll control in the event of a failure in the primary roll control system not involving

jammed ailerons. Aileron trim operates on 28 VDC supplied through the 2-amp ROLL TRIM circuit breaker on Main Bus 1.

## **Yaw Trim System**

Yaw trim is provided by spring cartridge attached to the rudder pedal torque tube and console structure. The spring cartridge provides a centering force regardless of the direction of rudder deflection. The yaw trim is ground adjustable only.

On airplanes with electric rudder (yaw) trim, trim changes are pilot controlled through a linear actuator connected to a hinged trim tab on the rudder trailing edge. The actuator is installed in the rudder. A RUDDER TRIM indicator with integral rocker switch is mounted in the console immediately adjacent to the FLAP control switch. Pressing the left half of the switch initiates Nose L trim and pressing the right half initiates Nose R trim. A needle sweeps the trim indicator scale to indicate trim position. The full Nose Right trim tic is labeled TAKEOFF. Rudder (yaw) trim operates on 28 VDC supplied through the 2-amp PITCH / YAW TRIM circuit breaker on Main Bus 1. The switch and indicator are not internally illuminated.

## Flight Deck Arrangement

The following paragraphs are a general description of the flight deck, instruments, and controls. Details relating to the instruments, switches, circuit breakers, and controls on the instrument panel, bolster, and center console are located with the description of the affected system.

### Instrument Panel

The instrument panel is designed for glare-free use in all flight conditions. The instrument panel is arranged primarily for use by the pilot in the left seat; however, it can be viewed from either seat. Flight instruments and annunciators are located on the left side of the panel and engine instruments are located on the right side of the instrument panel. A large color multifunction display is located between the flight instruments and the engine instruments. Temperature controls are located on the right side below the engine instruments.

The SR22 uses standard flight instruments arranged in the 'basic-six' pattern. They include:

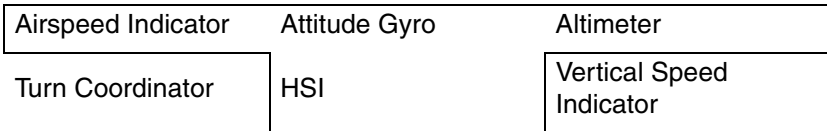

Additionally, an electronic clock and VOR/LOC/ILS (CDI) are located immediately to the left of the flight instruments on the instrument panel.

A switch panel located in the “dash board” bolster below the flight instruments contains the master and ignition switches, avionics power switch, pitot heat switch, and lighting switches.

A parking brake knob is mounted below the flight instruments inboard of the pilot at knee level.

*Serials 0435 and subsequent with PFD:* The instrument panel is designed for glare-free use in all flight conditions. The instrument panel is arranged primarily for use by the pilot in the left seat; however, it can be viewed from either seat.

The airplane is equipped with an Avidyne FlightMax Entegra-Series Primary Flight Display (PFD). The PFD is a 10.4” landscape-oriented display intended to be the primary display of primary flight parameter



information (attitude, airspeed, heading, and altitude) to the pilot. The PFD accepts data from a variety of sources, including the GPS sensors, the System 55X Autopilot, and is the primary heading source for the Multifunction Display.

The PFD replaces the following instruments:

- HSI
- Vertical Speed Indicator
- VOR/LOC Indicator
- Altitude Alerter
- OAT/Clock Indicator

Backup altimeter, airspeed, and attitude indicators are mounted on the bolster panel in case of total or partial PFD failure. To provide roll data to the autopilot system, a Turn Coordinator is mounted behind the RH bolster panel.

Flight instruments and annunciators are located on the left side of the panel and engine instruments are located on the right side of the instrument panel. A large color multifunction display is located between the flight instruments and the engine instruments. Temperature controls are located on the right side below the engine instruments.

*Refer to Section 9, Supplements for specific operational information on the PFD.*

## Center Console

A center console contains the avionics, flap control and position lights, power lever and mixture controls, fuel system indicator and controls, and audio controls. System circuit breakers, the alternate static source valve, alternate induction air control, and ELT panel switch are located on the left side of the console for easy access by the pilot. A friction knob for adjusting throttle and mixture control feel and position stability is located on the right side of the console. An accessory outlet, map compartment, audio jacks, hour meter, emergency egress hammer, and headset jacks are installed inside the console armrest.

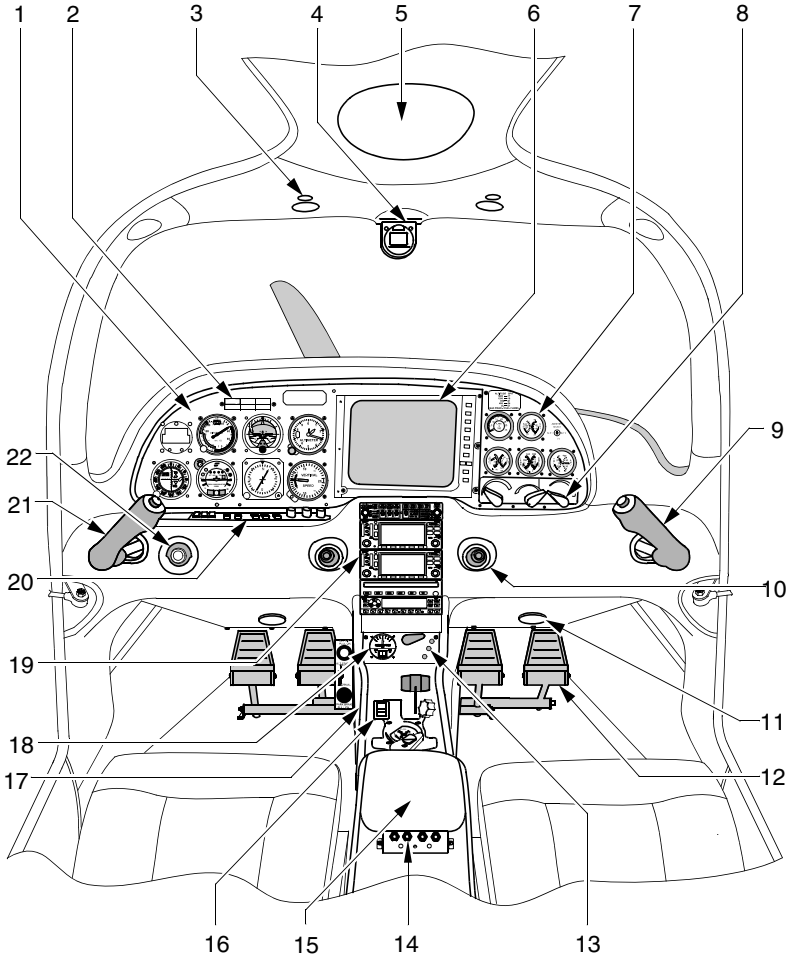

**Legend**

- |  |  |   |
|--|--|---|
| <ul style="list-style-type: none"> <li>1. Flight Instrument Panel</li> <li>2. Annunciator Panel</li> <li>3. Overhead Light &amp; Switch</li> <li>4. Magnetic Compass</li> <li>5. Cirrus Airframe Parachute System (CAPS) Activation T-Handle Cover</li> <li>6. ARNAV Multifunction Display</li> <li>7. Engine Instruments</li> <li>8. Temperature/Ventilation Controls</li> <li>9. Control Yoke</li> <li>10. Fresh Air "Eyeball" Outlet</li> </ul> | <ul style="list-style-type: none"> <li>11. Conditioned Air Outlet</li> <li>12. Rudder Pedals</li> <li>13. Flap Control &amp; Position Indicators</li> <li>14. Passenger Audio Jacks</li> <li>15. Armrest</li> <li>16. Engine &amp; Fuel System Controls</li> <li>17. Left Side Console                             <ul style="list-style-type: none"> <li>· Circuit Breaker Panel</li> <li>· Alternate Engine Air</li> <li>· Parking Brake</li> <li>· Alternate Static Source</li> </ul> </li> </ul> | <ul style="list-style-type: none"> <li>18. Rudder Trim Switch/Indicator</li> <li>19. Avionics Panel</li> <li>20. Bolster Switch Panel</li> <li>21. Control Yoke</li> <li>22. Start/Ignition Key Switch</li> </ul> |
|--|--|---|

SR22\_FM07\_1455A

**Figure 7-5**  
**Instrument Panel and Console (Sheet 1 of 2)**

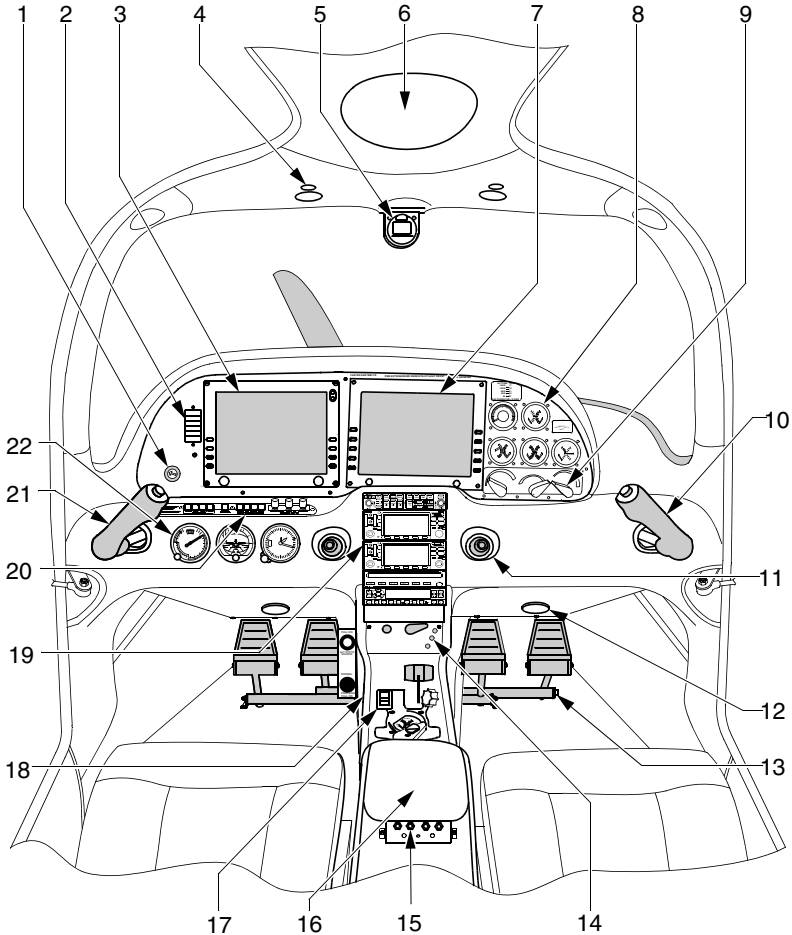

**Legend**

- |   |  |                             |
|---|--|-----------------------------|
| 1. Start/Ignition Key Switch  | 9. Temperature/Ventilation Controls    | 18. Left Side Console       |
| 2. Annunciator Panel  | 10. Control Yoke                       | · Circuit Breaker Panel     |
| 3. Primary Flight Display   | 11. Fresh Air "Eyeball" Outlet         | · Alternate Engine Air      |
| 4. Overhead Light & Switch  | 12. Conditioned Air Outlet             | · Parking Brake             |
| 5. Magnetic Compass   | 13. Rudder Pedals                      | · Alternate Static Source   |
| 6. Cirrus Airframe Parachute System<br>(CAPS) Activation T-Handle Cover | 14. Flap Control & Position Indicators | 19. Avionics Panel          |
| 7. Multifunction Display  | 15. Passenger Audio Jacks              | 20. Bolster Switch Panel    |
| 8. Engine Instruments   | 16. Armrest                            | 21. Control Yoke            |
|   | 17. Engine & Fuel System Controls      | 22. Flight Instrument Panel |

SR22\_FM07\_1730

**Figure 7-5**  
**Instrument Panel and Console (Sheet 2 of 2)**

# Airplane Cabin

## Cabin Doors

### • Caution •

*Serials 0795, 0820 and subsequent:* The seat back must be in the fully upright or the fully reclined position before closing the cabin door. Seat backs in the forward or break-over position can cause damage to the door handle or interior panel.

Two large forward hinged doors allow crew and passengers to enter and exit the cabin. The door handles engage latching pins in the door frame receptacles at the upper aft and lower aft door perimeter. Gas charged struts provide assistance in opening the doors and hold the doors open against gusts. Front seat armrests are integrated with the doors. A key lock in each door provides security. The cabin door keys also fit the baggage compartment door lock. Separate keys are provided for the fuel caps.

## Windshield and Windows

The windshield and side windows are manufactured of acrylic. Use only clean soft cloths and mild detergent to clean acrylic surfaces. *Refer to Section 8* for detailed cleaning instructions.

## Baggage Compartment

The baggage compartment door, located on the left side of the fuselage aft of the wing, allows entry to the baggage compartment. The baggage door is hinged on the forward edge and latched on the rear edge. The door is locked from the outside with a key lock. The baggage compartment key will also open the cabin doors.

The baggage compartment extends from behind the rear passenger seat to the aft cabin bulkhead. The rear seats can be folded forward to provide additional baggage area for long or bulky items.

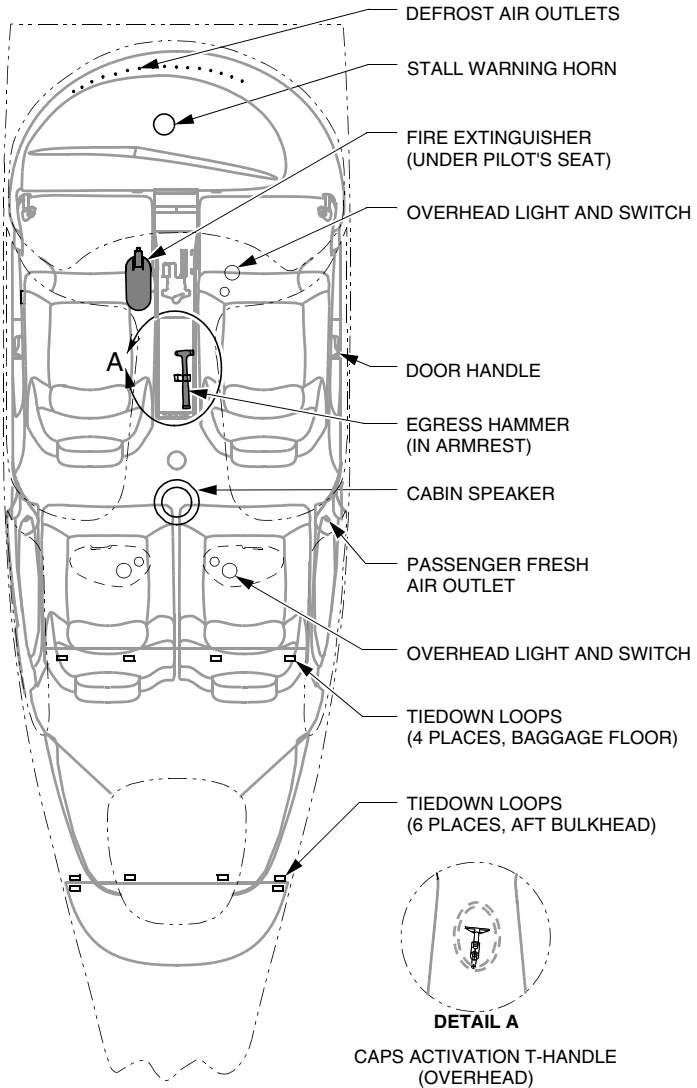

SR22\_FM07\_1064

**Figure 7-6**  
**Cabin General Arrangement**

Four baggage tie-down straps are provided to secure baggage and other items loaded in the baggage compartment. Each strap assembly has a hook at each end and a cam-lock buckle in the middle. The hook ends clip over loop fittings installed in the baggage floor and in the aft bulkhead. The tie-down straps should be stowed attached and tightened to the fittings.

To install tie-down strap:

1. Position straps over baggage. Thread straps through luggage handles if possible.
2. Clip hook ends of straps over loop fittings.
3. Grasp the buckle and pull the loose strap end of each strap to tighten straps over contents of baggage compartment.

To loosen tie-down straps:

1. Lift buckle release and pull on buckle to loosen strap.
2. Lift hook ends free of loop fittings.

## **Seats**

The seating arrangement consists of two individually adjustable seats for the pilot and front seat passenger and two individual seats with fold down seat backs for the rear seat passengers.

The front seats are adjustable fore and aft and the seat backs can be reclined for passenger comfort or folded forward for rear seat access. Integral headrests are provided. The fore and aft travel path is adjusted through the seat position control located below the forward edge of the seat cushion. The seat track is angled upward for forward travel so that shorter people will be positioned slightly higher as they adjust the seat forward. Recline position is controlled through levers located on each side of the seat backs. Depressing the recline release control while there is no pressure on the seat back will return the seat back to the full up position.

### **• Caution •**

The seat bottoms have an integral aluminum honeycomb core designed to crush under impact to absorb downward loads. To avoid crushing this core, do not kneel or stand on the seats.

To position front seat fore and aft:

1. Lift the position control handle.
2. Slide the seat into position.
3. Release the handle and check that the seat is locked in place.

To adjust recline position:

1. Actuate and hold the seat back control lever.
2. Position the seat back to the desired angle.
3. Release the control lever.

Each rear seat consists of a fixed seat bottom, a folding seat back, and a headrest. The seat backs can be unlatched from inside the baggage compartment and folded forward to provide a semi-flat surface for bulky cargo extending forward from the baggage compartment.

To fold seat back forward:

1. From the baggage access, lift the carpet panel at lower aft edge of seat to reveal the seat back locking pins (attached to lanyards).
2. Remove the locking pins and fold seat forward.

## Cabin Safety Equipment

### *Passenger Restraints*

Integrated seat belt and shoulder harness assemblies with inertia reels are provided for the pilot and each passenger. The rear seat belts are attached to fittings on the floorboard and the forward seat belts are attached to the seat frame. The shoulder harnesses are attached to inertia reels mounted in the seat back for the front seats and on the baggage compartment rear bulkhead for the rear seats. Each harness is attached to the seat belt. The buckle half of each assembly is on the left-hand side and the link half is on the right-hand side. The inertia reels allow complete freedom of movement of the occupant's upper torso. However, in the event of a sudden deceleration, the reels lock automatically to protect the occupants. It is recommended that the seat belts be stowed in the latched position when not in use.

• Note •

No slack may exist between the occupant's shoulder and restraint harness shoulder strap.

To use the restraints:

1. Slip arms behind the harness so that the harness extends over shoulders.
2. Hold the buckle and firmly insert the link.
3. Grasp the seat belt tabs outboard of the link and buckle and pull to tighten. Buckle should be centered over hips for maximum comfort and safety.
4. Restraint harnesses should fit snug against the shoulder with the lap buckle centered and tightened around the hips.

To release the restraints:

1. Grasp the top of the buckle opposite the link and pull outward. The link will slip free of buckle.
2. Slip arms from behind the harness.



### ***Emergency Egress Hammer***

An eight-ounce ball-peen type hammer is located in the center armrest accessible to either front seat occupant. In the event of a mishap where the cabin doors are jammed or inoperable, the hammer may be used to break through the acrylic windows to provide an escape path for the cabin occupants.

### ***Fire Extinguisher***

A liquefied-gas-type fire extinguisher, containing Halon 1211/1301 extinguishing agent, is mounted on the forward inboard side of the pilot's seat base. The extinguisher is approved for use on class B (liquid, grease) and class C (electrical equipment) fires. The Halon 1211/1301 blend provides the best fire extinguishing capability with low toxicity. A pin is installed through the discharge mechanism to prevent inadvertent discharge of extinguishing agent. The fire extinguisher must be replaced after each use.

To operate the extinguisher:

1. Loosen retaining clamp and remove the extinguisher from its mounting bracket.
2. Hold the extinguisher upright and pull the pin.
3. Get back from the fire and aim nozzle at base of fire at the nearest edge.
4. Press red lever and sweep side to side.

### **• WARNING •**

Halon gas used in the fire extinguisher can be toxic, especially in a closed area. After discharging fire extinguisher, ventilate cabin by opening air vents and unlatching door. Close vents and door after fumes clear.

The extinguisher must be visually inspected before each flight to assure that it is available, charged, and operable. The preflight inspection consists of ensuring that the nozzle is unobstructed, the pin has not been pulled, and the canister has not been damaged. Additionally, the unit should weigh approximately 1.5 lb (0.7 kg). For preflight, charge can be determined by 'hefting' the unit.

## Landing Gear

### Main Gear

The main landing gear are bolted to composite wing structure between the wing spar and shear web. The landing gear struts are constructed of composite material for fatigue resistance. The composite construction is both rugged and maintenance free. The main wheels and wheel pants are bolted to the struts. Each main gear wheel has a 15 x 6.00 x 6 tire with innertube installed. Standard wheel pants are easily removable to provide access to tires and brakes. Access plugs in the wheel pants can be removed to allow tire inflation and pressure checking. Each main gear wheel is equipped with an independent, hydraulically operated, single-disc type brake.

### Nose Gear

The nose gear strut is of tubular steel construction and is attached to the steel engine mount structure. The nosewheel is free casting and can turn through an arc of approximately 216 degrees (108 degrees either side of center). Steering is accomplished by differential application of individual main gear brakes. The tube-type nosewheel tire is 5.00 x 5.

### Brake System

The main wheels have hydraulically operated, single-disc type brakes, individually activated by floor mounted toe pedals at both pilot stations. A parking brake mechanism holds induced hydraulic pressure on the disc brake for parking.

The brake system consists of a master cylinder for each rudder pedal, a hydraulic fluid reservoir, a parking brake valve, a single disc brake assembly on each main landing gear wheel, and associated hydraulic plumbing. Braking pressure is initiated by depressing the top half of a rudder pedal (toe brake). The brakes are plumbed so that depressing either the pilot's or copilot's left or right toe brake will apply the respective (left or right) main wheel brake. The reservoir is serviced with Mil-H-5606 hydraulic fluid.

Brake system malfunction or impending brake failure may be indicated by a gradual decrease in braking action after brake application, noisy or dragging brakes, soft or spongy pedals, excessive travel, and/or

weak braking action. Should any of these symptoms occur, immediate maintenance is required. If, during taxi or landing roll, braking action decreases, let up on the pedals and then reapply the brakes with heavy pressure. If the brakes are spongy or pedal travel increases, pumping the pedals may build braking pressure.

### ***Parking Brake***

The main wheel brakes are set for parking by using the PARK BRAKE knob on the left side of the console near the pilot's right ankle. Brake lines from the toe brakes to the main wheel brake calipers are plumbed through a parking brake valve. For normal operation, the knob is pushed in. With the knob pushed in, poppets in the valve are mechanically held open allowing normal brake operation. When the handle is pulled out, the parking brake valve holds applied brake pressure, locking the brakes. To apply the parking brake, set the brakes with the rudder-pedal toe brakes, and then pull the PARK BRAKE knob aft.

#### **• Caution •**

Do not pull the PARK BRAKE knob in flight. If a landing is made with the parking brake valve set, the brakes will maintain any pressure applied after touchdown.

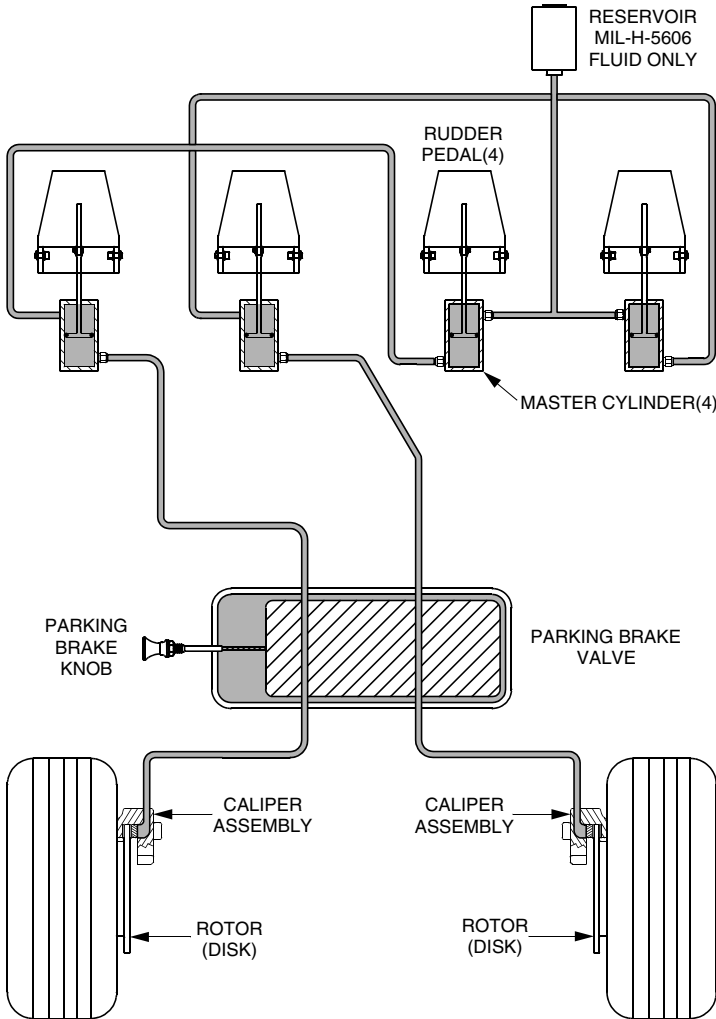

SR22\_FM07\_1015

**Figure 7-7**  
**Brake System**

## Engine

The SR22 is powered by a Teledyne Continental IO-550-N, six-cylinder, normally aspirated, fuel-injected engine rated to 310 hp at 2700 RPM. The engine has a 2000-hour Time Between Overhaul (TBO). Dual, conventional magnetos provide ignition.

*Serials 0002 thru 0819 before Service Bulletin SB 2X-71-06;* The engine is attached to the firewall by a four-point steel engine mount.

*Serials 0002 thru 0819 after Service Bulletin SB 2X-71-06 and airplane serials 0820 and subsequent.* The engine is attached to the firewall by a six-point steel engine mount.

The firewall attach points are structurally reinforced with gusset-type attachments that transfer thrust and bending loads into the fuselage shell.

## Engine Oil System

The engine is provided with a wet-sump, high-pressure oil system for engine lubrication and cooling. Oil for engine lubrication is drawn from an eight-quart capacity sump through an oil suction strainer screen and directed through the oil filter to the engine-mounted oil cooler by a positive displacement oil pump. The oil pump is equipped with a pressure relief valve at the pump output end to bypass oil back to the pump inlet should the pump exceed limits. The oil cooler is equipped with a temperature control valve set to bypass oil if the temperature is below 180° F (82° C). Bypass or cooled oil is then directed through oil galleries to the engine rotating parts and piston inner domes. Oil is also directed to the propeller governor to regulate propeller pitch. The complete oil system is contained in the engine. An oil filler cap and dipstick are located at the left rear of the engine. The filler cap and dipstick are accessed through a door on the top left side of the engine cowling.

### • Caution •

The engine should not be operated with less than six quarts of oil. Seven quarts (dipstick indication) is recommended for extended flights.

## Engine Cooling

Engine cooling is accomplished by discharging heat to the oil and then to the air passing through the oil cooler, and by discharging heat directly to the air flowing past the engine. Cooling air enters the engine compartment through the two inlets in the cowling. Aluminum baffles direct the incoming air to the engine and over the engine cylinder cooling fins where the heat transfer takes place. The heated air exits the engine compartment through two vents in the aft portion of the cowling. No movable cowl flaps are used.

## Engine Fuel Injection

The multi-nozzle, continuous-flow fuel injection system supplies fuel for engine operation. An engine driven fuel pump draws fuel from the selected wing tank and passes it to the mixture control valve integral to the pump. The mixture control valve proportions fuel in response to the pilot operated mixture control lever position. From the mixture control, fuel is routed to the fuel-metering valve on the air-induction system throttle body. The fuel-metering valve adjusts fuel flow in response to the pilot controlled Power Lever position. From the metering valve, fuel is directed to the fuel manifold valve (spider) and then to the individual injector nozzles. The system meters fuel flow in proportion to engine RPM, mixture setting, and throttle angle. Manual mixture control and idle cut-off are provided. An electric fuel pump provides fuel boost for vapor suppression and for priming.

## Engine Air Induction System

Induction air enters the engine compartment through the two inlets in the forward cowling. The air passes through a dry-foam induction filter, through the throttle butterfly, into the six-tube engine manifold, and finally through the cylinder intake ports into the combustion chambers. Should the dry induction filter become clogged, a pilot controlled alternate induction air door can be opened, allowing engine operation to continue. *Refer to Engine Controls, Alternate Air Control.*

## Engine Fuel Ignition

Two engine driven magnetos and two spark plugs in each cylinder provide fuel ignition. The right magneto fires the lower right and upper left spark plugs, and the left magneto fires the lower left and upper

right spark plugs. Normal operation is conducted with both magnetos, as more complete burning of the fuel air mixture with dual ignition.

## Engine Exhaust

Engine exhaust gases are routed through a tuned exhaust system. After leaving the cylinders, exhaust gases are routed through the exhaust manifold, through a muffler located on the right side of the engine or, *airplane serials 0320 and subsequent*, through mufflers located on either side of the engine, then overboard through an exhaust pipe(s) exiting through the lower cowling. A muff type heat exchanger, located around the right muffler, provides cabin heat.

## Engine Controls

Engine controls are easily accessible to the pilot on a center console. They consist of a single-lever power (throttle) control and a mixture control lever. A friction control wheel, labeled FRICTION, on the right side of the console is used to adjust control lever resistance to rotation for feel and control setting stability. An alternate induction air source control is also provided.

### ***Power (Throttle) Lever***

The single-lever throttle control, labeled MAX-POWER-IDLE, on the console adjusts the engine throttle setting in addition to automatically adjusting propeller speed. The lever is mechanically linked by cables to the air throttle body/fuel-metering valve and to the propeller governor. Moving the lever towards MAX opens the air throttle butterfly and meters more fuel to the fuel manifold. A separate cable to the propeller governor adjusts the governor oil pressure to increase propeller pitch to maintain engine RPM. The system is set to maintain approximately 2500 RPM throughout the cruise power settings and 2700 RPM at full power.

### ***Mixture Control***

The mixture control lever, labeled RICH-MIXTURE-CUTOFF, on the console adjusts the proportion of fuel to air for combustion. The Mixture Control Lever is mechanically linked to the mixture control valve in the engine-driven fuel pump. Moving the lever forward (towards RICH) repositions the valve allowing greater proportions of fuel and moving the lever aft (towards CUTOFF) reduces (leans) the

proportion of fuel. The full aft position (CUTOFF) closes the control valve.

### **Start/Ignition Switch**

• Note •

*Airplane serials 0435 and subsequent with PFD:* The Start/Ignition Switch is located on the instrument panel.

A rotary-type key switch, located on the left bolster, controls ignition and starter operation. The switch is labeled OFF-R-L- BOTH-START. In the OFF position, the starter is electrically isolated, the magnetos are grounded and will not operate. Normally, the engine is operated on both magnetos (switch in BOTH position) except for magneto checks and emergency operations. The R and L positions are used for individual magneto checks and for single magneto operation when required. When the battery master switch is ON, rotating the switch to the spring loaded START position energizes the starter and activates both magnetos. The switch automatically returns to the BOTH position when released.

### **Alternate Air Control**

An Alternate Induction Air Control knob, labeled ALT AIR – PULL, is installed on the left console near the pilot's right ankle. To operate the control, depress the center lock button, pull the knob to the open position, and then release the lock button. Pulling the knob opens the alternate air induction door on the engine induction air manifold, bypasses the air filter, and allows warm unfiltered air to enter the engine. Alternate induction air should be used if blocking of the normal air source is suspected. Operation using alternate induction air should be minimized and the cause of filter blocking corrected as soon as practical.

### **Engine Indicating**

The SR22 is equipped with engine instruments and warning lights to monitor the engine performance. The instruments are located on the right side of the instrument panel and the warning lights are located in the annunciator panel immediately in front of the pilot.



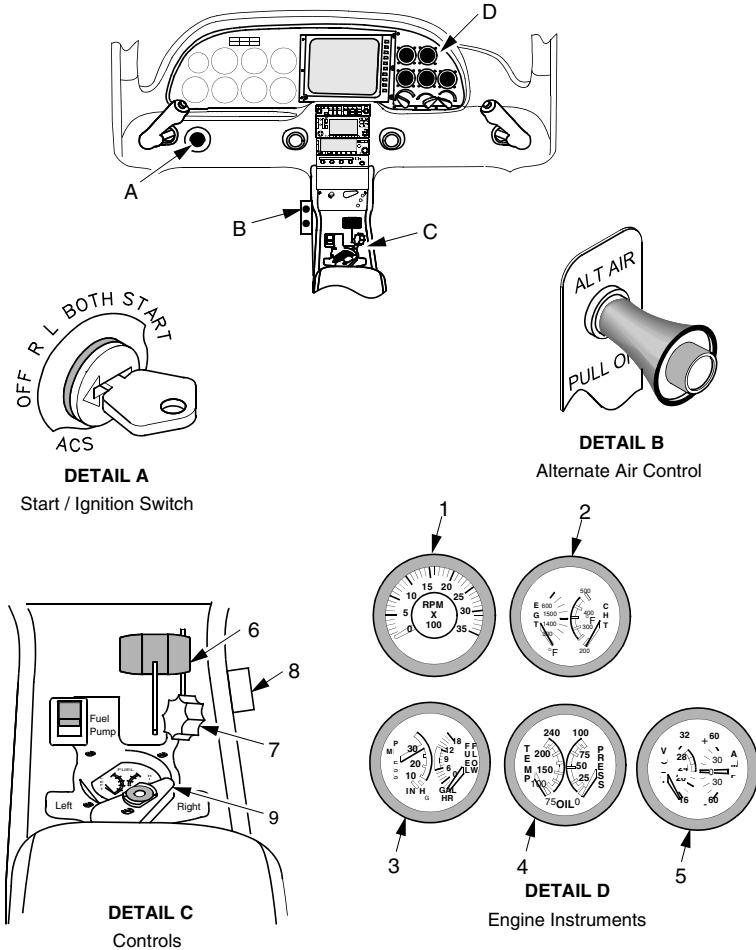

**DETAIL A**  
Start / Ignition Switch

**DETAIL B**  
Alternate Air Control

**DETAIL C**  
Controls

**DETAIL D**  
Engine Instruments

**LEGEND**

- |                                |                     |
|--------------------------------|---------------------|
| 1. Tachometer                  | 6. Power Lever      |
| 2. EGT/CHT                     | 7. Mixture Control  |
| 3. Manifold Pressure/Fuel Flow | 8. Friction Control |
| 4. Oil Temp/Pressure           | 9. Fuel Selector    |
| 5. Volt/Ammeter                |                     |

SR22\_FM07\_1603

**Figure 7-8**  
**Engine Controls & Indicators**

### ***Oil Warning Light***

The red OIL warning light in the annunciator panel comes on to indicate either high oil temperature or low oil pressure. The light is illuminated by a switch in the oil temperature gage if the oil temperature reaches 240° F or by a switch in the oil pressure gage if the oil pressure drops to 10 psi or less. If the OIL warning light comes on in flight, refer to the oil temperature and pressure gages to determine the cause. Typically, low oil pressure will be accompanied by a high oil temperature indication. The light is powered by 28 VDC through the 2-amp ANNUN circuit breaker on the Essential Bus.

### ***Tachometer***

A 2¼" tachometer is mounted on the right instrument panel adjacent to the other engine instruments. The tachometer pointer sweeps a scale marked from 0 to 3500 RPM in 100 RPM increments. *Refer to Section 2, Limitations*, for instrument limit markings. The electrically operated tachometer receives a speed signal from a magnetic pickup on the right hand magneto. 28 VDC for instrument operation is supplied through the 5-amp ENGINE INST circuit breaker on Main Bus 1.

### ***Exhaust Gas Temp / Cylinder Head Temp Gage***

• Note •

*Serials 0435 and subsequent with Engine Monitoring:* The airplane is not equipped with an EGT/CHT gage.

A 2¼" combination Exhaust Gas Temperature (EGT) and Cylinder Head Temperature (CHT) indicator is mounted in the right instrument panel. 28 VDC for instrument operation is supplied through the 5-amp ENGINE INST circuit breaker on Main Bus 1.

The EGT pointer sweeps a scale marked from 1250° F to 1650° F in 25° F increments. The EGT scale has no limit markings. The electrically operated EGT indicator receives a temperature signal from a thermocouple mounted in the exhaust stream of the #4 cylinder exhaust pipe.

The CHT pointer sweeps a scale marked from 200° F to 500° F. *Refer to Section 2, Limitations*, for instrument limit markings. The electrically operated CHT indicator receives a temperature signal from a temperature sensor mounted in the #6 cylinder head on the left side of the engine.

### ***Oil Temperature / Oil Pressure Gage***

A 2¼" combination Oil Temperature and Oil Pressure indicator is mounted on the right instrument panel immediately below the EGT/CHT indicator. The instrument is internally lighted. 28 VDC for instrument operation is supplied through the 5-amp ENGINE INST circuit breaker on Main Bus 1.

The Oil Temperature pointer sweeps a scale marked from 50° F to 250° F in 25° F increments. *Refer to Section 2, Limitations*, for instrument limit markings. The Oil Temperature indicator receives a temperature signal from a temperature sending unit mounted at the lower left side of the engine below the oil cooler.

The Oil Pressure pointer sweeps a scale marked from 0 psi to 100 psi. *Refer to Section 2, Limitations* for instrument limit markings. The Oil Pressure indicator receives a pressure signal from an oil pressure sensor mounted at the aft end of the engine below the oil cooler. Normally, oil pressure may drop to 10 psi at idle but will be in the 30 - 60 psi range at higher RPM.

### ***Fuel Flow / Manifold Pressure Gage***

A 2¼" combination Fuel Flow and Manifold Pressure indicator is mounted on the right instrument panel immediately below the tachometer. The indicator is internally lighted. 28 VDC for instrument operation is supplied through the 5-amp ENGINE INST circuit breaker on Main Bus #1.

The Fuel Flow pointer sweeps a scale marked from 0 to 30 Gal/Hr. *Refer to Section 2, Limitations* for instrument limit markings. The electrically operated Fuel Flow indicator receives a fuel-flow rate signal from a fuel-flow transducer on the right side of the engine in the fuel line between the throttle body metering valve and the injector manifold (spider).

The Manifold Pressure pointer sweeps a scale marked from 10 to 30 inches Hg in one-inch Hg increments. *Refer to Section 2, Limitations*, for instrument limit markings. The electrically operated manifold pressure indicator receives a pressure signal from a pressure sensor mounted in the induction airstream on the left side of the induction air manifold near the throttle body.

## **Propeller**

The airplane is equipped with a constant-speed, aluminum-alloy propeller with a three-blade (78" diameter) propeller and governor.

The propeller governor automatically adjusts propeller pitch to regulate propeller and engine RPM. The propeller governor senses engine speed by means of flyweights and senses throttle setting through a cable connected to the power (throttle) control lever in the cockpit. The propeller governor boosts oil pressure in order to regulate propeller pitch position. Moving the throttle lever forward causes the governor to meter less high-pressure oil to the propeller hub allowing centrifugal force acting on the blades to lower the propeller pitch for higher RPM operation. Reducing the power (throttle) lever position causes the governor to meter more high-pressure oil to the propeller hub forcing the blades to a higher pitch, lower RPM, position. During stabilized flight, the governor automatically adjusts propeller pitch in order to maintain an RPM setting (throttle position). Any change in airspeed or load on the propeller results in a change in propeller pitch.

## Fuel System

An 81-gallon usable wet-wing fuel storage system provides fuel for engine operation. The system consists of a 42-gallon capacity (40.5-gallon usable) vented integral fuel tank and a fuel collector/sump in each wing, a three position selector valve, an electric boost pump, and an engine-driven fuel pump. Fuel is gravity fed from each tank to the associated collector sumps where the engine-driven fuel pump draws fuel through a filter and selector valve to pressure feed the engine fuel injection system. The electric boost pump is provided for engine priming and vapor suppression.

Each integral wing fuel tank has a filler cap in the upper surface of each wing for fuel servicing. Access panels in the lower surface of each wing allow access to the associated wet compartment (tank) for inspection and maintenance. Float-type fuel quantity sensors in each wing tank and each collector tank supply fuel level information to the fuel quantity indicators. Positive pressure in the tank is maintained through a vent line from each wing tank. Fuel, from each wing tank, gravity feeds through strainers and a flapper valve to the associated collector tank in each wing. Each collector tank/sump incorporates a flush mounted fuel drain and a vent to the associated fuel tank.

The engine-driven fuel pump pulls filtered fuel from the two collector tanks through a three-position (LEFT-RIGHT-OFF) selector valve. The selector valve allows tank selection. From the fuel pump, the fuel is proportioned to the induction airflow, metered to a flow divider, and delivered to the individual cylinders. Excess fuel is returned to the selected tank.

A dual-reading fuel-quantity indicator is located in the center console next to the fuel selector in plain view of the pilot. Fuel shutoff and tank selection is positioned nearby for easy access.

Fuel system venting is essential to system operation. Blockage of the system will result in decreasing fuel flow and eventual engine fuel starvation and stoppage. Venting is accomplished independently from each tank by a vent line leading to a NACA-type vent mounted in an access panel underneath the wing near each wing tip.

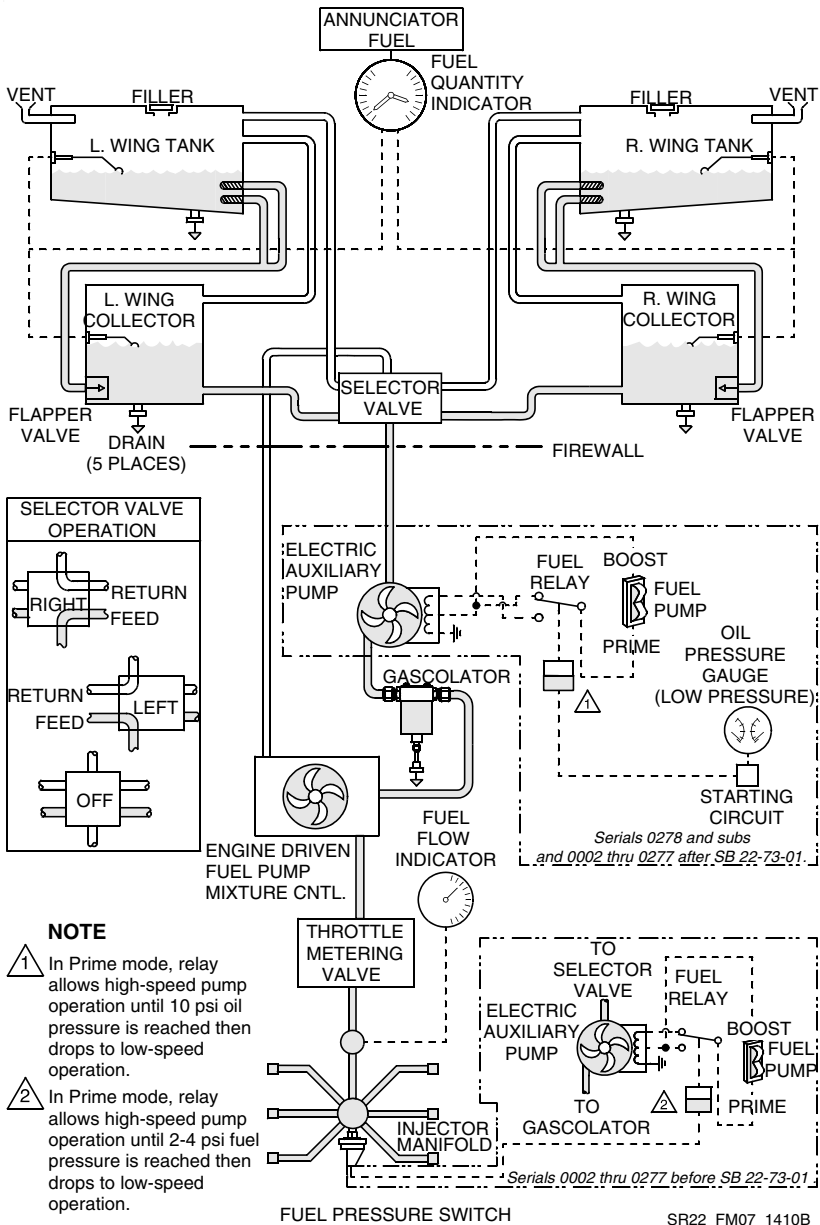

FUEL PRESSURE SWITCH

SR22\_FM07\_1410B

**Figure 7-9**  
**Fuel System**

The airplane may be serviced to a reduced capacity to permit heavier cabin loadings. This is accomplished by filling each tank to a tab visible below the fuel filler, giving a reduced fuel load of 23.5 gallons usable in each tank (47 gallons total usable in all flight conditions).

Drain valves at the system low points allow draining the system for maintenance and for examination of fuel in the system for contamination and grade. The fuel must be sampled prior to each flight. A sampler cup is provided to drain a small amount of fuel from the wing tank drains, the collector tank drains, and the gascolator drain. If takeoff weight limitations for the next flight permit, the fuel tanks should be filled after each flight to prevent condensation.

## Fuel Caution Light

The amber FUEL caution light in the annunciator panel comes on to indicate a low fuel condition. The light is illuminated by switches in the fuel quantity indicator if the fuel quantity in both tanks drops below approximately 14 gallons (28 gallons total with tanks balanced in level flight). Since both tanks must be below 14 gallons to illuminate the light, the light could illuminate with as little as 14 gallons in one tank during level flight if the other tank is allowed to run dry. If the FUEL caution light comes on in flight, refer to the Fuel Quantity gages to determine fuel quantity. The light is powered by 28 VDC through the 2-amp ANNUN circuit breaker on the Essential Bus.

## Fuel Quantity Indicator

A dual reading 2¼" fuel quantity indicator is installed on the console immediately forward of the fuel selector valve. The LEFT pointer indicates left tank fuel quantity and sweeps a scale marked from 0 to 41 U.S. gallons in 5-gallon increments. The RIGHT pointer sweeps an identical scale for the right tank. Each scale is marked with a yellow arc from 0 to 14 U.S. gallon. The indicators are calibrated to read '0' when no usable fuel remains. Each indicator also provides an output signal to illuminate the FUEL caution light when the fuel quantity goes below approximately 14 gallons in each tank. The fuel quantity indications are derived from float-type fuel-level sensors installed in each main tank and each collector tank. The indicator is internally lighted. 28 VDC for fuel quantity system operation is supplied through the 5-amp ENGINE INST circuit breaker on Main Bus 1.

• Note •

When the fuel tanks are 1/4 full or less, prolonged uncoordinated flight such as slips or skids can uncover the fuel tank outlets. Therefore, if operating with one fuel tank dry or if operating on LEFT or RIGHT tank when 1/4 full or less, do not allow the airplane to remain in uncoordinated flight for periods in excess of 30 seconds.

## Fuel Selector Valve

A fuel selector valve, located at the rear of the center console, provides the following functions:

- LEFT .....Allows fuel to flow from the left tank
- RIGHT ..... Allows fuel to flow from the right tank
- OFF .....Cuts off fuel flow from both tanks

The valve is arranged so that to feed off a particular tank the valve should be pointed to the fuel indicator for that tank. To select RIGHT or LEFT, rotate the selector to the desired position. To select Off, first raise the fuel selector knob release and then rotate the knob to OFF.

## Boost Pump Switch

Boost pump operation and engine prime is controlled through the Fuel Pump BOOST-PRIME switch located adjacent to the fuel selector valve. The PRIME position is momentary and the BOOST position is selectable. A two-speed prime allows the fuel pressure to rapidly achieve proper starting pressure.

*Serials 0002 thru 0277 before SB 22-73-01:* For engine starting, pressing PRIME causes the boost pump to operate at high speed until the fuel pressure reaches 2-4 psi. When the fuel pressure reaches the 2-4 psi range, a pressure switch in the fuel injection line switches the boost pump to the low-speed mode to provide a 4-6 psi fuel pressure boost. Selecting BOOST energizes the boost pump in low-speed mode to deliver a continuous 4-6 psi boost to the fuel flow for vapor suppression in a hot fuel condition.

*Serials 0278 and subs, and serials 0002 thru 0277 after SB 22-73-01:* An oil pressure based system is used to control boost pump operation. The oil pressure/oil temperature gauge provides a signal to the starting circuit to generate a ground for the oil annunciator and the fuel



system. This system allows the fuel pump to run at high speed (PRIME) when the engine oil pressure is less than 10 PSI. Whenever the engine oil pressure exceeds 10 PSI, pressing PRIME will have no effect. Selecting BOOST energizes the boost pump in low-speed mode regardless of oil pressure to deliver a continuous 4-6 psi boost to the fuel flow for vapor suppression in a hot fuel condition.

The boost pump operates on 28 VDC supplied through the 5-amp FUEL PUMP circuit breaker on Main Bus 2.

## Electrical System

The airplane is equipped with a two-alternator, two-battery, 28-volt direct current (VDC) electrical system designed to reduce the risk of electrical system faults. The system provides uninterrupted power for avionics, flight instruments, lighting, and other electrically operated and controlled systems during normal operation.

### Power Generation

Primary power for the SR22 is supplied by a 28-VDC, negative-ground electrical system. The electrical power generation system consists of two alternators controlled by a Master Control Unit (MCU) mounted on the left side of the firewall and two batteries for starting and electrical power storage.

Alternator 1 (ALT 1) is a gear-driven, internally rectified, 60-amp alternator mounted on the right front of the engine. Alternator 2 (ALT 2) is a gear-driven, internally rectified, 20-amp alternator mounted on the accessory drive at the rear of the engine. ALT 1 is regulated to 28 volts and ALT 2 is regulated to 28.75 volts. The output from ALT 1 is connected to the main distribution bus in the MCU through an 80-amp fuse. The output from ALT 2 is connected to the essential distribution bus in the MCU through a 40-amp fuse. Both alternators are self-exciting (not self-starting) and require battery voltage for field excitation in order to start up - for this reason, the batteries should not be turned off in flight.

Battery 1 (BAT 1) is an aviation grade 12-cell, lead-acid, 24-volt, 10-amp-hour battery mounted on the right firewall. BAT 1 is charged from the main distribution bus in the MCU. Battery 2 (BAT 2) is composed of two 12-volt, 7-amp-hour, sealed, lead-acid batteries connected in series to provide 24 volts. Both BAT 2 units are located in a vented, acid-resistant container mounted behind the aft cabin bulkhead (FS 222) below the parachute canister. BAT 2 is charged from the circuit breaker panel Essential bus.

The Master Control Unit (MCU) is located on the left firewall. The MCU controls ALT 1, ALT 2, starter, landing light, external power, and power generation functions. In addition to ALT 1 and ALT 2 voltage regulation, the MCU also provides external power reverse polarity protection, alternator overvoltage protection, as well as alternator fail and overcurrent annunciations. Power is distributed to the airplane circuit panel buses through main and essential buses in the MCU. During normal operation, the alternators feed their respective distribution bus independently (ALT 1 feeds main distribution bus and ALT 2 feeds the essential distribution bus). The distribution busses are interconnected by two 50-amp fuses and a diode. The diode prevents ALT 2 from feeding the main distribution bus. Additionally, since ALT 2 / essential distribution bus voltage is slightly higher than ALT 1 / main distribution bus voltage, ALT 1 will not feed the essential distribution bus unless ALT 2 fails.

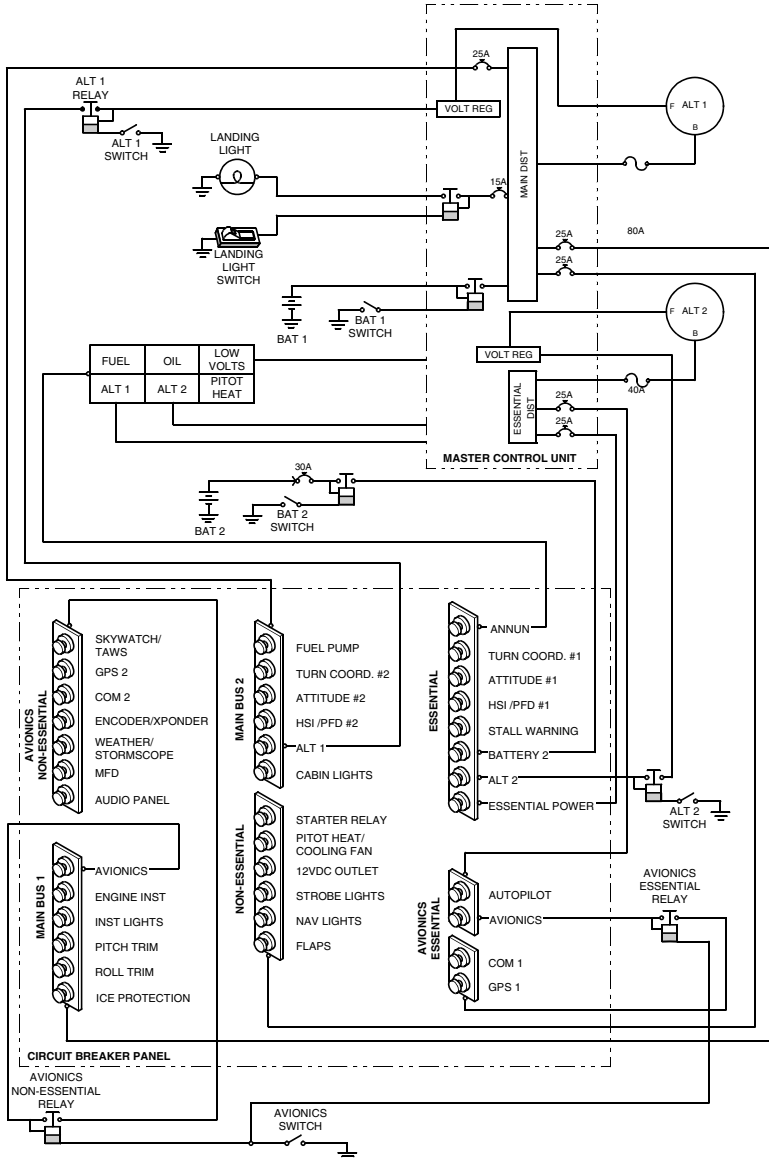

SR2\_FM07\_1458D

Figure 7-10  
Electrical Power & Distribution

## Power Distribution

The power distribution system for the SR22 consists of the main distribution bus and the essential distribution bus in the MCU and associated buses in the Circuit Breaker panel. The circuit breaker panel is located on the left side of the console next to the pilots right knee.

For normal operation, the Essential Buses in the circuit breaker panel are powered from the essential distribution bus in the MCU through 25-amp circuit breakers. BAT 2 is connected directly to the Essential Bus in the circuit breaker panel and will power the bus should the voltage coming from the MCU distribution buses drop below the battery voltage. Additionally, in the event of an ALT 2 failure, the circuit breaker panel Essential Bus will be powered from ALT 1 through the main distribution and essential distribution buses in the MCU. Main Bus 1, Main Bus 2, and the equipment Non-Essential Bus in the circuit breaker panel are powered from ALT 1 through the main distribution bus in the MCU. The Avionics Non-Essential Bus in the circuit breaker panel is powered from circuit breaker panel Main Bus 1.

## BAT & ALT Master Switches

The rocker type electrical system MASTER switches are ON in the up position and OFF in the down position. The switches, labeled BAT 2, BAT 1, ALT 1, ALT 2 are located in the bolster switch panel immediately below the instrument panel. These switches, along with the AVIONICS power switch, control all electrical power to the airplane.

### ***Battery Switches***

The BAT 1 and BAT 2 switches control the respective battery. Setting the BAT 1 switch 'on' energizes a relay connecting BAT 1 to the MCU distribution buses (also energizing the circuit breaker panel buses) and the open contacts of the starter relay. Setting the BAT 2 switch 'on' energizes a relay connecting BAT 2 to the circuit breaker panel Essential Buses. Normally, for flight operations, all master switches will be 'on.' However, the BAT 1 and BAT 2 switches can be turned 'on' separately to check equipment while on the ground. Setting only the BAT 2 switch 'on' will energize those systems connected to the circuit breaker panel Essential Bus. If any system on the other buses is energized, a failure of the distribution bus interconnect isolation diode

is indicated. When the BAT 1 switch is set to 'on,' the remaining systems will be energized. To check or use avionics equipment or radios while on the ground, the AVIONICS power switch must also be turned on.

### **Alternator Switches**

The ALT 1 and ALT 2 switches control field power to the respective alternator. For ALT 1 to start, the BAT 1 switch must be 'on.' Setting the ALT 1 switch 'on' energizes a relay allowing 28 VDC from the ALT 1 circuit breaker (Main Bus 2) to be applied to voltage regulator for ALT 1. For ALT 2 to start, either the BAT 1 switch or the BAT 2 switch must be 'on.' Setting the ALT 2 switch 'on' energizes a relay allowing 28 VDC from the ALT 2 circuit breaker (Essential Bus) to be applied to voltage regulator for ALT 2. Positioning either ALT switch to the OFF position removes the affected alternator from the electrical system.

• Note •

Continued operation with the alternators switched off will reduce battery power low enough to open the battery relay, remove power from the alternator field, and prevent alternator restart.

### **Avionics Power Switch**

A rocker switch, labeled AVIONICS, controls electrical power from the circuit breaker panel bus to the avionics bus. The switch is located next to the ALT and BAT Master switches. Typically, the switch is used to energize or de-energize all avionics on the Avionics Non-Essential and Essential buses simultaneously. With the switch in the OFF position, no electrical power will be applied to the avionics equipment, regardless of the position of the master switch or the individual equipment switches. For normal operations, the AVIONICS switch should be placed in the OFF position prior to activating the MASTER switches, starting the engine, or applying an external power source.

### **Low-Volts Warning Light**

The airplane is equipped with a red LOW VOLTS warning light in the annunciator panel located on the left side of the instrument panel. A voltage sensor in the (MCU) monitors voltage on the Essential Bus and illuminates the warning light when the voltage is less than approximately 24.5 volts.

• Note •

The LOW VOLTS warning light may come on during extended low RPM operation with heavy electrical loads. Under these conditions, the light will go out at higher RPM.

## **Volt / Amp Meter**

A 2¼" combination Volts and Ampere meter is mounted on the right instrument panel immediately outboard of the oil temperature and pressure indicator. The indicator is internally lighted. 28 VDC for instrument lighting is supplied through the 2-amp INST LIGHTS circuit breaker on Main Bus 1.

The VOLT pointer sweeps a scale from 16 to 32 volts. *Refer to Section 2, Limitations*, in basic POH for instrument limit markings. The voltage indication is measured off the essential bus.

The AMP pointer sweeps a scale from -60 to +60 amps with zero at the 9 o'clock position. The amps indication is derived from current transducers located in the MCU. Output from each alternator and BAT 1 is measured. The panel mounted AMMETER SELECT switch is used to select the desired indication. When the engine is operating and the ALT 1 and ALT 2 Master switches are 'on,' the ammeter indicates the charging rate applied to the batteries. In the event the alternators are not functioning or the electrical load exceeds the output of the alternators, the ammeter indicates BAT 1 discharge rate. Alternator ammeter indications are positive only.

### ***Ammeter Select Switch***

The AMMETER SELECT switch on the instrument panel is used to select the desired source of electrical current flow to be indicated on the ammeter. The switch has three positions: ALT 1, BATT, and ALT 2. The BATT position indicates BAT 1 current flow only. Selecting one of the switch positions will cause the amperage output from that device to be displayed on the ammeter.

## **ALT Fail Caution Lights**

Two ALT Fail caution lights are installed in the annunciator panel. The ALT 1 and ALT 2 caution lights in the annunciator panel provide annunciation of alternator failure or overcurrent conditions at the respective alternator. The lights are operated by circuits in the MCU

and current sensors on the ALT 1 and ALT 2 output lines. Steady illumination of either light indicates an alternator failure. A flashing ALT light indicates an overcurrent condition.

## **Circuit Breakers and Fuses**

Individual electrical circuits connected to the Main, Essential, and Non-Essential buses in the airplane are protected by re-settable circuit breakers mounted in the circuit breaker panel on the left side of the center console.

### ***Essential Buses***

The circuit breaker panel Essential Bus is powered by ALT 2 from the MCU Essential Distribution bus through the 20-amp ESSENTIAL POWER circuit breaker and from BAT 2 through the 20-amp BATTERY 2 circuit breaker. The Essential Bus is also powered by ALT 1 and BAT-1 through an isolation diode connecting the Main and Essential Distribution Buses in the MCU. The autopilot and essential avionics equipment are powered directly from the Essential Distribution Bus in the MCU through a 25-amp circuit breaker on the distribution bus. Power from the 15-amp AVIONICS circuit breaker is also controlled through the AVIONICS master switch on the bolster switch panel.

### ***Main Buses***

The circuit breaker panel Main Bus 1 and Main Bus 2 are powered by ALT 1 and BAT 1 from the MCU Main Distribution Bus through 25-amp circuit breakers on the distribution bus. ALT 2 and BAT 2 are prevented from powering the Main Buses by the isolation diode interconnecting the MCU distribution buses. Loads on circuit breaker panel Main Buses are shed by pulling the individual circuit breakers. The 15-amp AVIONICS circuit breaker on Main Bus 1 powers all loads on the Non-Essential Avionics Bus. Power from the 15-amp AVIONICS circuit breaker is also controlled through the AVIONICS master switch on the bolster switch panel.

### ***Non-Essential Buses***

The circuit breaker panel contains two Non-Essential Buses, the Non-Essential Equipment Bus and the Avionics Non-Essential Bus. The Avionics Non-Essential Bus is powered through the 15-amp AVIONICS circuit breaker on Main Bus 1 and is discussed above. The Non-Essential Equipment Bus is powered by ALT 1 and BAT 1 from

the MCU Main Distribution Bus through a 25-amp circuit breaker. ALT 2 and BAT 2 are prevented from powering the Non-Essential Equipment Bus by the isolation diode interconnecting the MCU distribution buses. Loads on the Non-Essential Equipment Bus are shed by pulling the individual circuit breakers.

## **Ground Service Receptacle**

A ground service receptacle is located just aft of the cowl on the left side of the airplane. This receptacle is installed to permit the use of an external power source for cold weather starting and maintenance procedures requiring reliable power for an extended period. The external power source must be regulated to 28 VDC. The external power control contactor is wired through the BAT 1 Master switch so that the BAT 1 switch must be 'on' to apply external power.

*Refer to Section 8, Ground Handling, Servicing, and Maintenance, for use of external power and special precautions to be followed.*

## **Convenience Outlet**

A 12-volt convenience outlet is installed in the center console. The receptacle accepts a standard cigarette-lighter plug. The outlet may be used to power portable entertainment equipment such as CD players, cassette players, and portable radios. Amperage draw through the outlet must not exceed 3.5 amps. Power for the convenience outlet is supplied through the 5-amp 12VDC OUTLET circuit breaker on the Non-Essential Bus.



## Exterior Lighting

The airplane is equipped with standard wing tip navigation lights with integral anti-collision strobe lights. The separately controlled landing light is located in the lower cowl.

### Navigation Lights

The airplane is equipped with standard wing tip navigation lights. The lights are controlled through the NAV light switch on the instrument panel bolster. 28 VDC for navigation light operation is supplied through the 5-amp NAV LIGHTS circuit breaker on Non-Essential Bus.

### Strobe Light

Anti-collision strobe lights are installed integral with the standard navigation lights. Each strobe is flashed by a separate power supply. The strobe power supplies are controlled through the STROBE light switch on the instrument panel bolster. 28 VDC for strobe light and control circuits is supplied through the 5-amp STROBE LIGHTS circuit breaker on Non-Essential Bus.

### Landing Light

A High Intensity Discharge (HID) landing light is mounted in the lower engine cowl. The landing light is controlled through the LAND light switch on the instrument panel bolster.

Setting the LAND light switch 'ON' energizes the landing light control relay in the Master Control Unit (MCU) completing a 28 VDC circuit from the airplane main distribution bus to the light's ballast located on the firewall. The ballast provides boosted voltage to illuminate the HID lamp. A15-amp fuse on the main distribution bus in the MCU protects the circuit.

## Interior Lighting

Interior lighting for the airplane consists of separately controlled incandescent overhead lights for general cabin lighting, individual lights for the pilots and passengers, and dimmable panel floodlights. The flight instruments and avionics equipment lights are dimmable.

### Instrument Lights

Instrument lighting for the airplane consists of dimmable incandescent lights in the instrument bezels. The lights are controlled through the INST lights control on the instrument panel bolster. Rotating the knob clockwise energizes the lights and increases brightness. The instrument light circuits operate on 28 VDC supplied through the 2-amp INST LIGHTS circuit breaker on Main Bus 1.

### Panel Flood Lights

A string of red LEDs mounted under the instrument panel glareshield provide flood lighting for the instrument panel. The lights are controlled through the PANEL lights control on the instrument panel bolster. Rotating the knob clockwise energizes the lights and increases brightness. The panel lights operate on 28 VDC supplied through the 3-amp CABIN LIGHTS circuit breaker on Main Bus 2.

### Reading Lights

Individual eyeball-type reading lights are installed in the headliner above each passenger position. Each light is aimed by positioning the lens in the socket and is controlled by a push-button switch located next to the light. The pilot and copilot reading lights are also dimmable through the PANEL lights control on the instrument panel bolster. The lights are powered by 28 VDC supplied through the 3-amp CABIN LIGHTS circuit breaker on Main Bus 2.

### Overhead Dome Light

General cabin lighting is provided by a dome light located in the headliner at the approximate center of the cabin. The dome light is controlled through the OVERHEAD light control on the instrument panel bolster. Rotating the knob clockwise from the off position will illuminate the light and control its intensity. The lights are powered by 28 VDC supplied through the 3-amp CABIN LIGHTS circuit breaker on Main Bus 2.

## Environmental System

Cabin heating and ventilation is accomplished by supplying conditioned air for heating and windshield defrost and fresh air for ventilation. The conditioned air system consists of a heater muff (heat exchanger) around the right engine exhaust muffler, an air mixing plenum, air ducting for distribution, a windshield diffuser, forward outlet valves, and cable controls for selecting temperature and flow.

Ventilation air is provided by ducting fresh air from air inlets, located in each wing leading edge, to eyeball outlets for each occupant. Each occupant can direct the fresh air flow by positioning the nozzle or control flow rate from 'off' to maximum by rotating the nozzle.

Heating is accomplished by mixing ventilation air from the fresh air inlets with heated air from the heat exchanger and then distributing the 'conditioned' air to the occupants and/or the windshield diffuser. Air for heating is supplied by an inlet in the engine compartment to a muff-type heat exchanger surrounding the right engine exhaust muffler. This heated air is allowed to mix with fresh air from the wing root air inlets in the air mixing plenum behind the instrument panel. The proportion of heated to fresh air is pilot controllable. The mixed (conditioned) air is then directed to the passenger outlets and/or to the windshield diffuser. Conditioned air outlets for the forward occupants are directionally controllable and are located beneath the instrument panel at each position at knee level. Outlets for the rear occupants are at floor level.

The temperature, volume, and flow selection are regulated by manipulation of the cabin temperature and cabin air selector knobs on the lower right side of the instrument panel.

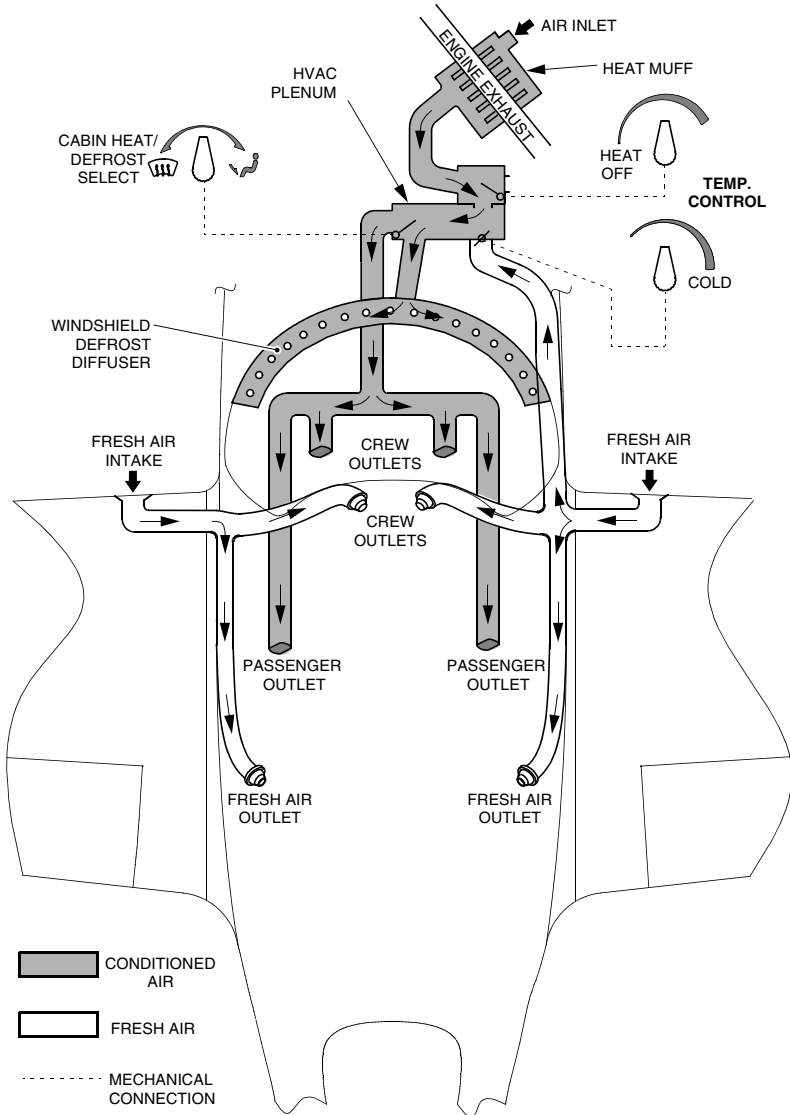

SR22\_FM07\_1012A

**Figure 7-11**  
**Heating and Ventilation**

## **Cabin Heat Control**

The amount of heated air allowed into the air mixing plenum is controlled by rotating the Cabin Heat Control, located inboard of the Cabin Air Selector. The control is mechanically linked to a door in a heater box between the heater muff and the mixing plenum. Rotating the control full counterclockwise (HEAT OFF) bypasses heated air from the heater muff into the engine compartment. Rotating the control clockwise opens the door in the heater box allowing heated air to enter the mixing plenum.

## **Cabin Cooling Control**

The amount of cooling air allowed into the air mixing plenum is controlled by rotating the Cabin Cool Control, located outboard of the Cabin Air Selector. The control is mechanically linked to a butterfly valve at the fresh air entrance to the mixing plenum. Rotating the control full counterclockwise shuts down cooling airflow to the mixing plenum from the fresh air inlet in the right wing root. Rotating the control clockwise opens the butterfly allowing fresh cooling air to enter the mixing plenum. Rotating the knob to the full clockwise (COLD) position provides maximum cooling airflow to the mixing plenum.

## **Cabin Air Selector**

Conditioned air from the mixing plenum can be proportioned and directed to the windshield or passengers by manipulating the Cabin Air Selector. The control is linked to a door at the outlet end of the mixing plenum. Rotating the control full counterclockwise to the miniature windshield shuts off airflow to the passenger air distribution system and allows maximum airflow to the windshield diffuser. Rotating the knob full clockwise to the seated person icon shuts off airflow to the windshield diffuser and allows maximum airflow to the passenger air distribution system. The control can be positioned to allow any proportion of windshield and passenger air.

Conditioned air for the forward seats is routed to outlets under the instrument panel at knee level. Conditioned air for the aft seats is ducted to outlets beneath the forward seats near the door posts and exits at floor level.

## Stall Warning System

The airplane is equipped with an electro-pneumatic stall warning system to provide audible warning of an approach to aerodynamic stall. The system consists of an inlet in the leading edge of the right wing, a pressure switch and associated plumbing, and a piezo-ceramic horn behind the instrument panel. As the airplane approaches a stall, the low pressure on the upper surface of the wings moves forward around the leading edge of the wings. As the low pressure area passes over the stall warning sense inlet, a slight negative pressure is sensed by the pressure switch. The pressure switch completes a ground circuit causing the warning horn to sound. The warning horn provides a 94dB continuous 2800 Hz tone. The warning sounds at approximately 5 knots above stall with full flaps and power off in wings level flight and at slightly greater margins in turning and accelerated flight. The system operates on 28 VDC supplied through the 2-amp STALL WARNING circuit breaker on the Essential Bus.

With battery power on, the stall warning system preflight check is accomplished as follows:

Stall warning system preflight check:

1. Place a clean handkerchief over the vent opening.
2. Use mouth or small suction cup and apply suction. A sound from the warning horn will confirm that the system is operative.

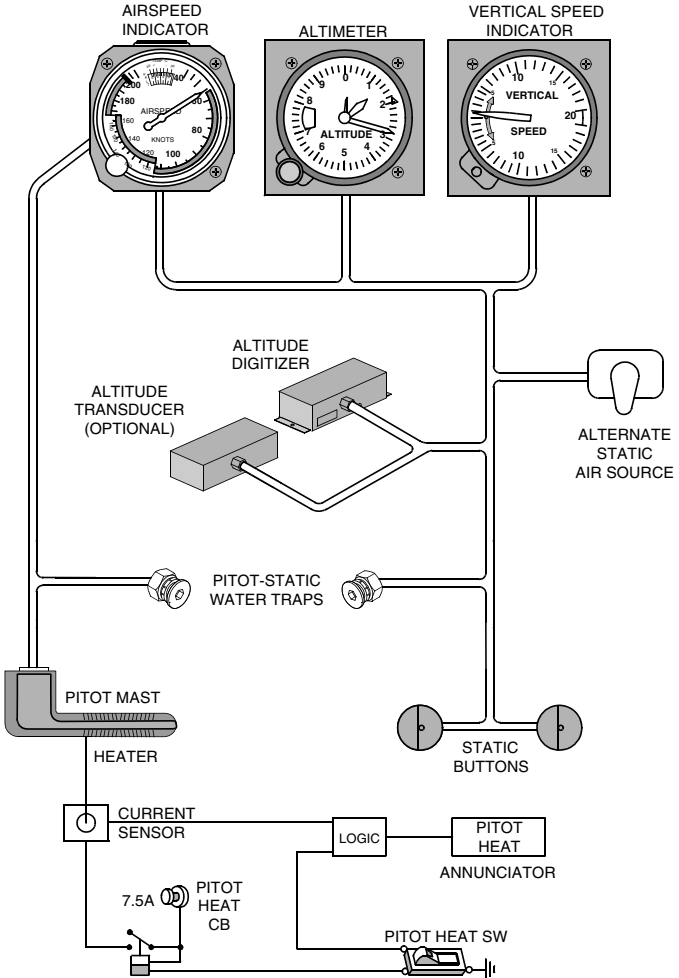

SR22\_FM07\_1013C

**Figure 7-12**  
**Pitot-Static System**

## Pitot-Static System

The Pitot-Static system consists of a single heated Pitot tube mounted on the left wing and dual static ports mounted in the fuselage. The Pitot heat is pilot controlled through a panel-mounted switch. An internally mounted alternate static pressure source provides backup static pressure should that the primary static source becomes blocked. Water traps with drains, under the floor in the cabin, are installed at each Pitot and static line low point to collect any moisture that enters the system. The traps should be drained at the annual inspection and when water in the system is known or suspected.

## Airspeed Indicator

• Note •

*Serials 0435 and subsequent with PFD:* The standby airspeed indicator is mounted on the LH bolster panel.

Indicated and true airspeeds are indicated on a dual-scale, internally lit precision airspeed indicator installed in the pilot's instrument panel. The instrument senses difference in static and pitot pressures and displays the result in knots on a airspeed scale. A single pointer sweeps an indicated airspeed scale calibrated from 40 to 220 knots. The 'zero' index is at the 12 o'clock position. A sub-scale aligns true airspeed with the corresponding indicated airspeed when the altitude/temperature correction is set in the correction window. A knob in the lower left corner of the instrument is used to rotate the pressure altitude scale in the correction window to align the current pressure altitude with the outside air temperature. *Refer to Section 2, Limitations,* for instrument limit markings.

## Vertical Speed Indicator

• Note •

*Serials 0435 and subsequent with PFD:* The Vertical Speed Indicator is integrated into the PFD.

Airplane rate of climb or descent in feet per minute is displayed on the internally lit Vertical Speed indicator installed in the pilot's instrument panel. The instrument senses rate of change in static pressure from a reference pressure and displays the result in climb or descent feet per minute (FPM). Climb is indicated by clockwise rotation of the pointer



from zero and descent is indicated by counter clockwise rotation. The '0' (zero) reference point is at the 9 o'clock position. The scale is calibrated from 0 to 2000 FPM in 100-FPM increments in both the 'UP' and 'DOWN' directions.

## Altimeter

• Note •

*Serials 0435 and subsequent with PFD:* The standby altimeter is mounted on the LH bolster panel.

Airplane altitude is depicted on a conventional, three-pointer, internally lit barometric altimeter installed in the pilot's instrument panel. The instrument senses the local barometric pressure adjusted for altimeter setting and displays the result on the instrument in feet. The altimeter is calibrated for operation between -1000 and 20,000 feet altitude. The scale is marked from 0 to 10 in increments of 2. The long pointer indicates hundreds of feet and sweeps the scale every 1000 feet (each increment equals 20 feet). The short, wide pointer indicates thousands of feet and sweeps the scale every 10,000 feet (each increment equals 200 feet). The short narrow pointer indicates tens of thousands feet and sweeps from 0 (zero) to 2 (20,000 feet with each increment equal to 2000 feet). Barometric windows on the instrument's face allow barometric calibrations in either inches of mercury (in.Hg) or millibars (mb). The barometric altimeter settings are input through the barometric adjustment knob at the lower left of the instrument.

## Pitot Heat Switch

The heated Pitot system consists of a heating element in the pitot tube, a rocker switch labeled PITOT HEAT, and associated wiring. The switch and circuit breaker are located on the left side of the switch and control panel. When the pitot heat switch is turned on, the element in the Pitot tube is heated electrically to maintain proper operation in possible icing conditions. Pitot heat should be used only when required. The Pitot heat system operates on 28 VDC supplied through the 7.5-amp PITOT HEAT/COOLING FAN circuit breaker on the Non-Essential electrical bus.

## Pitot Heat Light

Illumination of the amber PITOT HEAT caution light indicates that the Pitot Heat switch is in the 'on' position and the Pitot heater is not receiving electrical current. A current sensor on the Pitot heater power supply wire provides current sensing. The PITOT HEAT warning light operates on 28 VDC supplied through the 2-amp ANNUN circuit breaker on the Essential electrical bus.

## Alternate Static Source

An alternate static pressure source valve is installed on the switch and control panel to the right of the pilot's leg. This valve supplies static pressure from inside the cabin instead of the external static port. If erroneous instrument readings are suspected due to water or ice in the pressure line going to the standard external static pressure source, the alternate static source valve should be turned on. Pressures within the cabin will vary with open heater/vents. Whenever the alternate static pressure source is selected, *refer to Section 5 airspeed calibration and altitude* for corrections to be applied.

## Avionics and Navigation

• Note •

The following paragraphs and equipment descriptions describe the standard avionics in the SR22. For detailed descriptions of specific avionic equipment, operating procedures, or data for optional avionic equipment, *refer to the equipment manufacturer's pilot's guide and the FAA Approved Airplane Flight Manual Supplement in Section 9* for specific information regarding the SR22 installation.

The following avionic configurations are designed to provide the pilot with the most information in a format that is easily interpreted for best situational awareness. Additionally, these suites include different autopilots and HSI's, which are also covered here. The avionics navigation and communication components are mounted in the center console and are easily accessible from either pilot seat. Additional optional avionics equipment is available but is not covered here.

Standard avionics suites are available in the following configurations:

### **Avionics Configuration A:**

- Moving Map Display (Avidyne MFD)
- Two-Axis Autopilot (S-Tec System 30)
- Integrated Audio System with Intercom (Garmin GMA 340)
- Marker Beacon Receiver (Garmin GMA 340)
- Two IFR Approach-Certified GPS (Garmin GNS 430 and Garmin GNS 420)
- Two VHF Communications Transceivers (Garmin GNS 430 and Garmin GNS 420)
- Single Navigation (VOR/LOC/GS) Receiver (GNS 430)
- Mode C Transponder with Altitude Encoder (Garmin GTX 327)
- Horizontal Situation Indicator
- Course Deviation Indicator

### **Avionics Configuration B:**

- Moving Map Display (Avidyne MFD)
- Two-Axis Autopilot (S-Tec System 55X)

- Integrated Audio System with Intercom (Garmin GMA 340)
- Marker Beacon Receiver (Garmin GMA 340)
- Two IFR Approach-Certified GPS (Garmin GNS 430)
- Two VHF Communications Transceivers (Garmin GNS 430)
- Two Navigation (VOR/LOC/GS) Receiver (GNS 430)
- Mode C Transponder with Altitude Encoder (Garmin GTX 327)
- Electronic Navigation Display (Sandel SN3308)
- Course Deviation Indicator

***Avionics Configuration PFD - Serials 0435 and subsequent with PFD:***

- Moving Map Display (Avidyne MFD)
- Primary Flight Display (Avidyne PFD)
- Two-Axis Autopilot (S-Tec System 55X)
- Integrated Audio System with Intercom (Garmin GMA 340)
- Marker Beacon Receiver (Garmin GMA 340)
- Two IFR Approach-Certified GPS (Garmin GNS 430)
- Two VHF Communications Transceivers (Garmin GNS 430)
- Two Navigation (VOR/LOC/GS) Receiver (GNS 430)
- Mode C Transponder with Altitude Encoder (Garmin GTX 327)

**Avionics Power Switch**

*Refer to Avionics Power Switch description* under Electrical System in this section for a complete description of the Avionics Power Switch Functions.

**Magnetic Compass**

A conventional, internally lighted, liquid filled, magnetic compass is installed on the cabin headliner immediately above the windshield. A compass correction card is installed with the compass.

## Turn Coordinator

### ***Avionics Configuration A:***

The electric turn coordinator displays roll information and provides roll data to the integral System 30 autopilot. Roll rate is sensed by a single-gimbal, electric-powered gyro and displayed on the face of the instrument. The display consists of a symbolic airplane rotates to indicate turn rate and a standard glass tube and ball inclinometer. Markings, labeled L & R, indicate roll for a standard rate turn in the direction indicated. Redundant circuits paralleled through diodes at the indicator supply DC electrical power. 28 VDC for roll rate gyro operation is supplied through the 2-amp Turn Coord #1 circuit breaker on the Essential bus and the 2-amp Turn Coord #2 circuit breaker on the Main Bus 2.

### ***Avionics Configuration B:***

The electric turn coordinator, installed in the instrument panel, displays roll information and provides roll data to the System 55X autopilot. The instrument and power supplies are as described above.

## Attitude Indicator

- Note •

*Serials 0435 and subsequent with PFD:* The attitude indicator is mounted on the LH bolster panel.

The attitude indicator gives a visual indication of flight attitude. Bank attitude is indicated by a pointer at the top of the indicator relative to the bank scale with index marks at 10°, 20°, 30°, 60°, and 90° either side of the center mark. A fixed miniature airplane superimposed over a movable mask containing a white symbolic horizon bar, which divides the mask into two sections, indicates pitch and roll attitudes. The upper “blue sky” section and the lower “earth” sections have pitch reference lines useful for pitch attitude control. The indicator can follow maneuvers through 360° in roll and 360° in pitch. A knob at the bottom of the instrument allows adjustment of the miniature airplane to the horizon bar for a more accurate flight attitude indication.

A PULL TO CAGE knob on the indicator is used for quick erection of the gyro. When the caging knob is pulled, the pitch and roll indications will align to within 2° of their respective fixed references.

The instrument is electrically driven and a red GYRO flag indicates loss of electrical power. Redundant circuits paralleled through diodes at the indicator supply DC electrical power for gyro operation. 28 VDC for attitude gyro operation is supplied through the 3-amp Attitude #1 circuit breaker on the Essential bus and the 3-amp Attitude #2 circuit breaker on the Main Bus 2.

## **Course Deviation Indicator**

### ***Avionics Configuration A:***

The Course Deviation Indicator (CDI) displays navigation information from GPS 2 (Garmin GNC 420). The CDI displays GPS track deviation on a single deviation bar instrument. A vertical line displays GPS track deviation against a 5-dot scale. The indicator incorporates TO/FROM annunciation and NAV flag. An OBS knob is used to manually rotate the azimuth card to the desired bearing. 28 VDC for lighting is supplied through the 2-amp Inst Lights circuit breaker on Main Bus 1.

### ***Avionics Configuration B:***

The Course Deviation Indicator (CDI) displays navigation information from GPS 2 (Garmin GNS 430). Navigation source selection is made using the CDI button on the GPS 2 control. The CDI displays course deviation from a VOR or Localizer (LOC) and Glideslope when 'VLOC' is the selected navigation source and displays GPS track deviation when 'GPS' is the selected navigation source. The instrument has two deviation bars. The vertical line displays VOR/LOC or GPS track deviation against a 5-dot scale. The horizontal line displays glideslope deviation against a 5-dot scale. The indicator incorporates TO/FROM annunciation, NAV flag, and GS flag. An OBS knob is used to manually rotate the azimuth card to the desired bearing. 28 VDC for instrument lighting is supplied through the 2-amp Inst Lights circuit breaker on Main Bus 1.

## **Horizontal Situation Indicator**

### ***Avionics Configuration A:***

The Century NSD-1000 is a conventional HSI that provides gyro stabilized, magnetically slaved, heading information, a pictorial VOR/LOC display with a conventional course arrow, and glideslope presentation. The instrument displays airplane heading by rotating a compass dial in relation to a fixed simulated airplane image and lubber

line. The HSI directional gyro, which drives the compass dial, is slaved to a flux detector in the right wing through an amplifier under the copilot's floor. A FREE GYRO-SLAVE switch, below the display, allows the pilot to select either Free Gyro mode or Slave mode. In Slave mode, the gyro is slaved to the flux detector. In Free Gyro mode, the gyro must be manually set to the airplane's magnetic compass using the PUSH-SET-CARD knob in the lower right corner of the instrument. The course is set using the Course (Arrow) knob in the lower left corner of the instrument. The HSI course and heading outputs provided to the autopilot to allow NAV/LOC/GPS course tracking or to track a preset heading.

The HSI incorporates conventional warning flags. The HDG (Heading) flag will be out of view whenever the instrument is receiving sufficient electrical power for operation. The NAV (Navigation) flag will be out of view when a VOR or LOC frequency is tuned in the NAV1 receiver and a reliable signal is present. The GS (Glideslope) flag will be out of view when an ILS frequency is tuned on the Nav 1 receiver and a reliable GS signal is present.

The NSD-1000 HSI is electrically driven and a red GYRO flag indicates loss of electrical power. Redundant circuits paralleled through diodes at the indicator supply DC electrical power for gyro operation. 28 VDC for the redundant power circuits is supplied through the 5-amp HSI 1 circuit breaker on the Essential bus and 5-amp HSI 2 circuit breaker on Main Bus 2.

### ***Avionics Configuration B:***

The Sandel SN3308 combines the functions of an HSI, an RMI, a full color moving map, a Stormscope display, GPS annunciator, and 3-light marker beacon indicators. Compass information is derived from a remote directional gyro and a flux detector. Redundant power sources provide 28 VDC for system operation. Power is supplied through the 5-amp HSI #1 circuit breaker on the Essential Bus and the 5-amp HSI #2 circuit breaker on Main Bus 2. Either circuit is capable of powering the Navigation Display.

The full-color display uses a rear-projection system driven by an active matrix LCD display. The unit uses a halogen lamp as the singular primary display projection light source. A separate dimming knob for the display brightness is provided immediately below the display.

The HSI display shows heading and navigation information in a 360° view similar to a conventional mechanical HSI, or in an EFIS 90° ARC view. This includes compass card, heading bug, course pointer, course deviation bar, TO/FROM indicator, glideslope indicator, and flags. Heading bug and course pointer settings include digital readouts that make it easy to set precise headings and courses. One button operation allows primary navigation to be selected from up to four different sources: two VOR/ILS receivers and two GPS receivers. Either GPS1 or NAV1 may be selected as primary navigation sources. Up to two bearing pointers can be displayed and switched to any NAV receiver including GPS1, GPS2, NAV1, or NAV2. GPS2 and NAV2 can only be displayed as bearing pointers, not as a primary navigation source. The display is color-coded to indicate which navigation source is selected: green for NAV1, yellow for NAV2, and cyan for GPS.

Auto Slew automatically turns the course pointer in response to waypoint sequencing or Direct-To navigation from the GPS receiver eliminating manual course changes at waypoints and reducing pilot workload.

Heading and Course Sync allows the pilot, with one button, to automatically set the heading bug directly to his current heading, or to set the course pointer directly to a VOR station, simultaneously centering course deviation. Course and heading command outputs for autopilot operations are also provided.

The SN3308 detects and warns of abnormal conditions such as flagged navigation receivers and failed directional gyro or flux detector. It also monitors its own internal temperature and provides warnings for over-temperature or loss of cooling conditions.

Redundant circuits paralleled through diodes at the indicator supply DC electrical power for gyro operation. 28 VDC for the redundant power circuits is supplied through the 5-amp HSI 1 circuit breaker on the Essential bus and 5-amp HSI 2 circuit breaker on Main Bus 2.

Auto Slew automatically turns the course pointer in response to waypoint sequencing or Direct-To navigation from the GPS receiver eliminating manual course changes at waypoints and reducing pilot workload.

Heading and Course Sync allows the pilot, with one button, to automatically set the heading bug directly to his current heading, or to



set the course pointer directly to a VOR station, simultaneously centering course deviation. Course and heading command outputs for autopilot operations are also provided.

## Autopilot

### ***Avionics Configuration A:***

These airplanes are equipped with an S-TEC System Thirty Autopilot. This two-axis autopilot system receives roll axis control inputs from an integral electric turn coordinator and altitude information from an altitude transducer plumbed into the pitot-static system. The programmer, roll computer/amplifier, and annunciators are contained entirely within the turn coordinator case. The Multi-function Control Knob at the upper left of the turn coordinator provides mode selection, disengage, and turn command functions. A separate pitch computer provides the ALT hold function. Roll axis steering is accomplished by autopilot steering commands to the aileron trim motor and spring cartridge. Pitch axis command for altitude hold is accomplished by pitch computer commands to the elevator servo. The S-Tec System Thirty Autopilot features:

- Roll Stabilization;
- Turn Command;
- NAV/LOC/GPS tracking; HI and LO sensitivity;
- Altitude Hold; and
- GPS Steering (GPSS) for smoother turns onto a course or during course tracking.

A separate GPSS converter provides GPS roll steering to the autopilot. A GPSS/HDG button allows the operator to switch between HDG and Roll Steering modes. In the HDG mode the autopilot responds to the HDG bug on the HSI. In the GPSS mode, the autopilot responds to roll steering inputs from the GPS navigator.

*Refer to S-TEC System Thirty Autopilot Pilot's Operating Handbook (P/N 8777) dated Feb 1999 or later and the applicable POH supplement for a more complete description of the autopilot, its operating modes, and additional detailed operating procedures.*

*Refer to S-TEC-Meggitt Global Positioning System Steering (GPSS) Converter Pilot's Operating Handbook (P/N 8799) dated 8 Feb 2001 or*

later and applicable POH supplement for a more complete description of the GPSS converter, its modes, and additional operating procedures.

**Avionics Configuration B:**

These airplanes are equipped with an S-TEC System 55X Autopilot with Altitude Selector/Alerter. The System 55X autopilot is a two-axis autopilot system. The system consists of a flight guidance programmer/computer, altitude selector/alerter, altitude transducer, turn coordinator, and HSI. Mode selection and vertical speed selection are made on the programmer/computer panel. The altitude selector/alerter allows the pilot to pre-select altitudes and rates of climb or descent to be used by the autopilot. A button on each control yoke handle may be used to disengage the autopilot. The autopilot makes roll changes through the aileron trim motor and spring cartridge and makes pitch changes for altitude preselect and hold through the pitch servo actuator. The autopilot operates on 28 VDC supplied through the 5-amp Autopilot circuit breaker on the Essential Bus row. The S-Tec System 55X Autopilot features:

- Heading Hold and Command;
- NAV/LOC/GPS/GS tracking, high and low sensitivity, and automatic 45° -course intercept;
- Altitude and Climb/Descent Rate Preselect
- Altitude Hold and Command;
- Vertical Speed Hold and Command; and
- GPS Steering (GPSS) for smoother turns onto a course or during course tracking.

*Refer to S-Tec System Fifty-Five X Autopilot Pilot's Operating Handbook (POH), P/N 87109 dated 8 November 2000 or later revision for full operational procedures and description of implemented modes. The System 55X POH also contains detailed procedures for accomplishing GPS & VOR course tracking, front course and back course localizer approaches, and glideslope tracking.*

*Refer to S-Tec Altitude Selector / Alerter (P/N 0140) Pilot's Operating Handbook (POH), P/N 8716 (no revision or later) for full operational procedures and detailed description of operational modes of the Altitude Selector / Alerter.*

### **Avionics Configuration PFD:**

These airplanes are equipped with an S-TEC System 55X Autopilot. The System 55X autopilot is a two-axis autopilot system. The system consists of a flight guidance programmer/computer, and altitude transducer. Mode selection and vertical speed selection are made on the programmer/computer panel. A button on each control yoke handle may be used to disengage the autopilot. The autopilot makes roll changes through the aileron trim motor and spring cartridge and makes pitch changes for altitude preselect and hold through the pitch servo actuator. The autopilot operates on 28 VDC supplied through the 5-amp AUTOPILOT circuit breaker on the Essential Bus. The S-Tec System 55X Autopilot features:

- Heading Hold and Command;
- NAV/LOC/ /GS tracking, high and low sensitivity, GPSS roll steering, and automatic 45° course intercept;
- Altitude Hold and Command; and
- Vertical Speed Hold and Command.

*Refer to S-Tec System Fifty-Five X Autopilot Pilot's Operating Handbook (POH), P/N 87109 dated 8 November 2000 or later revision for full operational procedures and description of implemented modes. The System 55X POH also contains detailed procedures for accomplishing GPS & VOR course tracking, front course localizer approaches, and glideslope tracking.*

### **Audio System**

The Garmin GMA 340 audio control unit, located in the center console, provides audio amplification, audio selection, marker beacon control, and a voice activated intercom system for the cabin speaker, headsets, and microphones. The system allows audio switching for up to three transceivers (COM 1, COM 2, and COM 3) and five receivers (NAV 1, NAV2, ADF, DME, and MKR). In addition, there are two unswitched audio inputs for telephone ringer and altitude warning. Additional inputs are provided for two individual personal entertainment devices. Push buttons select the receiver audio source provided to the headphones. A fail-safe mode connects the pilot headphone and microphone to COM 1 if power is removed or if the Mic Selector switch is turned to the OFF position.

### ***Headset/Microphone Installation***

The airplane is equipped with provisions for four noise-canceling headsets with integrated microphones. The forward microphone-headsets use remote Push-To-Talk (PTT) switches located on the top of the associated control yoke grip. The rear headsets do not have COM transmit capabilities and do not require PTT switches. The microphone (MIC), headset, and automatic noise reduction (ANR) power jacks for the pilot and front seat passenger are located in the map case and similar jacks for the aft passengers are located on the aft portion of the center console. Audio to all four headsets is controlled by the individual audio selector switches on the audio control panel and adjusted for volume level by using the selected receiver volume controls.

### ***Audio Input Jack***

Two audio input jacks are provided on the aft portion of the center console. One jack is located near the convenience outlet for use by the pilot and forward passenger, and another is located further aft by the rear passenger ANR power jacks. These jacks can be used to plug in personal entertainment devices such as portable radios, cassette players, or CD players. Audio volume through these jacks is controlled by connected individual entertainment device.

### **Multi-Function Display**

This airplane is equipped with the Avidyne FlightMax EX-Series Multi-Function Display (MFD). The moving map display provides visual advisory of the airplane's GPS position against a moving map. This information supplements CDI or HSI course deviation and is advisory only. Additionally, The moving map display must not be used as the primary navigation instrument.

The Avidyne FlightMax EX-Series MFD is 10.4-inch diagonal color Active Matrix Liquid Crystal Display (AMLCD) integrated into a Control Display Unit (CDU), which displays the airplane current position and track against a moving map. Power for the MCU is 28 VDC supplied through the 5-amp MFD circuit breaker on the Avionics Non-Essential Bus.

The EX-Series MFD can perform the following functions:

- Generate and display a moving map based on GPS position data with obstacle and terrain data.
- Display Stormscope® lightning strike bearing and distance.
- Display Skywatch® traffic advisory information. (EX5000C only)
- Display a GPS flight plan based on pilot inputs.
- Display Normal and Emergency checklists as well as performance data.
- Display navigation data, such as groundspeed and track.

The pilot can configure the moving map display. Some of its configuration features are:

- Select Track-up or North-up modes.
- Select map scale.
- Select terrain features, such as airports and special use airspace and select color enhanced terrain.
- Select and view trip data from GPS.

## GPS Navigation

The Jeppesen Navigation Database provides access to data on Airports, Approaches, Standard Instrument Departures (SIDs), Standard Terminal Arrivals (STARs), VORs, NDBs, Intersections, Minimum Safe Altitudes, Controlled Airspace Advisories and Frequencies. North American and International databases are available. Database information is provided on a card that can be inserted into the card slot on the GPS unit. Subscription information is provided in a subscription packet provided with each system.

### ***Avionics Configuration A:***

The airplane is equipped with two GPS navigators. The Garmin GNS 430 is designated GPS 1 and the Garmin GNS 420 is designated GPS 2. Both Garmin GPS navigators are IFR certified. The primary unit, designated GPS 1, is coupled to the airplane's HSI, Autopilot, and multifunction display. The secondary unit, designated GPS 2, is coupled to the airplane's CDI.

The GPS navigators are capable of providing IFR enroute, terminal, and approach navigation with position accuracies better than 15

meters. Each GPS navigator utilizes the Global Positioning System (GPS) satellite network to derive the airplane's position (latitude, longitude, and altitude) and the altitude digitizer to enhance the altitude calculation.

The GPS1 antenna is located above the headliner along the airplane centerline. The GPS2 antenna is located below the glareshield and behind the MFD. All GPS navigator controls and functions are accessible through the GPS receiver units' front control panels located in the center console. The panels include function keys, power switches, MSG and NAV status annunciators, a color LCD display (GNS 430), two concentric selector knobs on each panel, and a Jeppesen NavData card slot in each panel. The displays are daylight readable and automatically dimmed for low-light operation. The primary GPS navigator is powered by 28 VDC through the 5-amp GPS 1 and 7.5-amp COM 1 circuit breakers on the Avionics Essential Bus. The secondary GPS navigator is powered by 28 VDC through the 5-amp GPS 2 and the 7.5-amp COM 2 circuit breaker on the Avionics Non-Essential Bus.

***Avionics Configuration B and PFD:***

The airplane is equipped with two GPS navigators. Dual Garmin GNS 430s are designated GPS 1 and GPS 2. Both Garmin GPS navigators are IFR certified. The primary unit, designated GPS 1, is coupled to the airplane's HSI or PFD, Autopilot, and multifunction display. The secondary unit, designated GPS 2, is coupled to the airplane's CDI or PFD.

The GPS navigators are capable of providing IFR enroute, terminal, and approach navigation with position accuracies better than 15 meters. Each GPS navigator utilizes the Global Positioning System (GPS) satellite network to derive the airplane's position (latitude, longitude, and altitude) and the altitude digitizer to enhance the altitude calculation.

The GPS1 antenna is located above the headliner along the airplane centerline. The GPS2 antenna is located below the glareshield and behind the MFD. All GPS navigator controls and functions are accessible through the GPS receiver units' front control panels located in the center console. The panels include function keys, power switches, MSG and NAV status annunciators, a color LCD display (GNS 430), two concentric selector knobs on each panel, and a

Jeppesen NavData card slot in each panel. The displays are daylight readable and automatically dimmed for low-light operation. The primary GPS navigator is powered by 28 VDC through the 5-amp GPS 1 and 7.5-amp COM 1 circuit breakers on the Avionics Essential Bus. The secondary GPS navigator is powered by 28 VDC through the 5-amp GPS 2 and the 7.5-amp COM 2 circuit breaker on the Avionics Non-Essential Bus.

## Communication (COM) Transceivers

### *Avionics Configuration A, B, and PFD:*

Two VHF communications (COM) transceivers are installed to provide VHF communication. The transceivers and integrated controls are mounted in the Garmin GNS 430 or GNS 420 units. The transceivers receive all narrow- and wide-band VHF communication transmissions transmitted within range of the selected frequency. The antennas pick up the signals and route the communication signals to the transceivers, which digitize the audible communication signal. The digitized audio is then routed to the audio control unit for distribution to the speakers or headphones.

COM 1 – The upper Garmin GNS 430 is designated COM 1. The Garmin GNS 430 control panel provides COM 1 transceiver active and standby frequency indication, frequency memory storage, and knob-operated frequency selection. The COM 1 transceiver provides either 720-channel (25 kHz spacing) or 2280-channel (8.33 kHz spacing) operation in a frequency range from 118.000 to 136.975 MHz. The COM 1 antenna is located above the cabin on the airplane centerline. 28 VDC for COM 1 transceiver operation is controlled through the Avionics Master Switch on the bolster switch panel and supplied through the 7.5-amp COM 1 circuit breaker on the Essential Avionics Bus.

COM 2 – The lower Garmin GNS 420 is designated COM 2. The Garmin GNS control panel provides COM 2 transceiver active and standby frequency indication, frequency memory storage, and knob-operated frequency selection. The COM 2 transceiver provides either 720-channel (25 kHz spacing) or 2280-channel (8.33 kHz spacing) operation in a frequency range from 118.000 to 136.975 MHz. The COM 2 antenna is located on the underside of the cabin on the airplane centerline. 28 VDC for COM 2 transceiver operation is

controlled through the Avionics Master Switch on the bolster switch panel and supplied through the 7.5-amp COM 2 circuit breaker on the Non-Essential Avionics Bus.

## Navigation (Nav) Receiver

### ***Avionics Configuration A:***

The airplane is equipped with one NAV receiver integrated into the Garmin GNS 430 GPS Navigators (the GNS 420 does not incorporate a NAV receiver). Mounted in the upper radio rack slot, this unit is designated NAV 1. The GNS 430 has VHF Omrange/Localizer (VOR/LOC) capability. The VOR/LOC receiver receives VOR/LOC on a frequency range from 108.000 Mhz to 117.950 Mhz with 50 kHz spacing. The GNS 430 has glideslope capability. Glideslope is received from 329.150 to 335.000 in 150 kHz steps. The receivers and integrated controls are mounted in the Garmin GNS 430 control display. The receiver controls provide active and standby frequency indication, frequency memory storage, and knob-operated frequency selection. IDENT audio output for VOR and LOC is provided to the audio system. The Nav antenna, mounted on top of the vertical tail, provides VOR/LOC input for both Nav receivers.

NAV 1 – The upper GARMIN GNS 430 is designated NAV 1. 28 VDC for navigation receiver operation is controlled through the Avionics Master Switch on the bolster switch panel and supplied through the 5-amp GPS1 circuit breaker on the Avionics Essential Bus row.

### ***Avionics Configuration B and PFD:***

The airplane is equipped with two NAV receivers integrated into the Garmin GNS 430 GPS Navigators. The upper unit is designated NAV 1 and the lower unit is designated NAV 2. The Nav receiver controls are integrated into the Garmin GNS control mounted in the center console. Each unit has VHF Omrange/Localizer (VOR/LOC) capability. The VOR/LOC receiver receives VOR/LOC on a frequency range from 108.000 Mhz to 117.950 Mhz with 50 kHz spacing. The GNS 430 has glideslope capability. Glideslope is received from 329.150 to 335.000 in 150 kHz steps. The receiver control provides active and standby frequency indication, frequency memory storage, and knob-operated frequency selection. IDENT audio output for VOR and LOC is provided to the audio system. The Nav antenna, mounted



on top of the vertical tail, provides VOR/LOC input for both Nav receivers.

NAV 1 – The upper GARMIN GNS 430 is designated NAV 1. 28 VDC for navigation receiver operation is controlled through the Avionics Master Switch on the bolster switch panel and supplied through the 5-amp GPS1 circuit breaker on the Avionics Essential Bus row.

NAV 2 – The lower GARMIN GNS 430 is designated NAV 2. 28 VDC for navigation receiver operation is controlled through the Avionics Master Switch on the bolster switch panel and supplied through the 5-amp GPS 2 circuit breaker on the Avionics Non-Essential Bus row.

## **Transponder**

The airplane is equipped with a single Garmin GTX 327 ATC Mode C (identification and altitude) transponder with squawk capability. The transponder system consists of the integrated receiver/transmitter control unit, an antenna, and an altitude digitizer. The receiver/transmitter receives interrogations from a ground-based secondary radar transmitter and then transmits to the interrogating Air Traffic Control Center. Digitized altitude information, provided by the altitude digitizer (encoder), is plumbed into the airplane static system. The transponder and integrated controls are mounted in the center console. The transponder control provides active code display, code selection, IDENT button, and test functions. A FUNC (function) key allows for selection of pressure altitude, flight time, count-up timer and countdown timer modes. The display is daylight readable and dimming is operator controlled through the INST lights control on the instrument panel bolster. The transponder antenna is mounted on the underside of the fuselage just aft of the firewall. 28 VDC for transponder operation is controlled through the Avionics Master Switch on the bolster switch panel. 28 VDC for receiver, transmitter, and altitude encoder operation is supplied through the 2-amp ENCODER/XPONDER circuit breaker on the Avionics Non-Essential Bus.

## Emergency Locator Transmitter

The airplane is equipped with a self-contained emergency locator transmitter (ELT). The transmitter and antenna are installed immediately behind the aft cabin bulkhead to the right of the airplane centerline. The main transmitter control switch, labeled ON-OFF-ARMED, on the transmitter is in the armed position for normal operations. A remote switch and indicator panel is installed immediately below the circuit breaker panel. The transmitter unit is mounted longitudinally in the airplane in order to detect deceleration greater than 3.5 ft/sec. If rapid deceleration is detected, the transmitter will repeatedly transmit VHF band audio sweeps at 121.5 MHz and 243.0 MHz approximately 0.5 seconds apart. The transmitter and attached portable antenna are accessible through an access at the base of the baggage compartment bulkhead. The ELT can be removed from the airplane and used as a personal locating device if it is necessary to leave the airplane after an accident. Eight dated "D" cell alkaline batteries contained within the transmitter unit power the ELT transmitter. The batteries must be replaced at specified intervals based upon the date appearing on the battery (*refer to SR22 Airplane Maintenance Manual*).

### ***ELT Remote Switch and Indicator Panel***

The ELT remote switch and indicator panel located immediately below the circuit breaker panel, provides test and monitoring functions for the ELT. The panel contains a button labeled ON, a button labeled RESET, and a red LED (light). The red light flashes when the ELT is transmitting. The ON button is used to test the unit in accordance with the maintenance manual procedures. The RESET button can be used to cancel an inadvertent transmission. A 6-volt Lithium battery mounted in the panel powers the LED. The battery must be replaced at regular intervals (*refer to Airplane Maintenance Manual*).

In the event of an accident:

1. Verify ELT operation by noting that the ELT indicator light on the remote panel is flashing.
2. If possible, access the unit as described below and set the ELT main transmitter control switch ON.

Portable use of ELT:

- a. Remove access at lower aft center of baggage compartment.
- b. Disconnect fixed antenna lead from front of unit.
- c. Disconnect lead from remote switch and indicator unit.
- d. Loosen attach straps and remove transmitter unit and portable antenna.
- e. Attach portable antenna to antenna jack on front of unit.
- f. Set main control switch to ON.
- g. Hold antenna upright as much as possible.

## Hour Meter

The airplane is equipped with an hour meter to record engine operating time. The hour meter is located inside the armrest storage compartment between the pilot and copilot seats. The hour meter records time when BAT 1 switch is ON and the ALT 1 or ALT 2 switch is set to ON. Power for hour meter operation is 28VDC supplied through the 5-amp ENGINE INST circuit breaker on Main Bus 1.

## Digital Clock

*Serials 1005 through 0434;* The airplane is equipped with a 2¼" Davtron M803 digital clock located on the left instrument panel immediately outboard of the airspeed indicator. The clock provides Universal Time (UT), Local Time (LT), Elapsed Time (ET), Outside Air Temperature (OAT) in °C or °F, and Voltmeter functions. All features and functions are selectable from control buttons on the clock face. The clock receives the OAT signal from a temperature sensor installed immediately forward of the pilots door. The clock operates on 28 VDC supplied through the 5-amp Engine Inst circuit breaker on Main Bus 1. Keep-alive power is supplied through a 5-amp fuse connected to the airplane main distribution bus in the Master Control Unit (MCU). A replaceable AA battery is installed to provide up to three years battery back up.

### ***SEL and CTL Buttons***

All time keeping and set functions are addressable using the Select and Control buttons below the time display. Upon power up the clock will display Universal Time (UT). Pressing the Select button 3 times

will display Local Time (LT), and Elapsed Time (ET) sequentially. Pressing the button again will return the display to UT.

*Set UT or LT:*

Use the Select button to select UT or LT as desired. Simultaneously press Select and Control buttons (tens of hours LED will flash). Press Control button repeatedly as required to increment digit to desired value. Press Select button to select the next digit to be set. After all digits have been set, press the Select button again to return to the normal mode.

*Flight Time (FT):*

The flight time (FT) option is not available in this installation. If FT is selected the display will 'zero.'

*Elapsed Time (ET):*

The ET mode may be used either in 'count-up' or in 'count-down' modes.

To set the count-up mode:

1. Select ET using the Select button; and
2. Press Control to activate count-up timer. Elapsed time counts up to 59 minutes, 59 seconds, and then switches to hours and minutes. Pressing the Control button again will reset the timer to zero.

To set the count-down mode:

1. Select ET using the Select button;
2. Input a 'count-down' time using the same technique as setting UT or LT (a maximum of 59 minutes, 59 seconds may be entered);
3. Press the Select button to exit the set mode; and
4. Press Control to start the count down. At zero, the alarm activates and the display flashes. Pressing either Select or Control deactivates the alarm.

*Test Mode:*

To enter the self-test mode, hold the Select button for 3 seconds. The display will indicate "88:88" and all four (UT, LT, FT, ET) annunciators will come on.

### ***OAT – VOLTS Button***

*Serials 1005 through 0434;* The red OAT-VOLTS button is used to display Outside Air Temperature and airplane main bus voltage. When the airplane is powered down, the upper display will display the clock's back-up battery voltage. Upon power up, the display will show the airplane's main bus voltage. Pressing the button displays OAT in °F. Pressing the button again displays OAT in °C.

*Serials 0435 and subsequent with PFD:* Outside Air Temperature annunciation is integrated into the PFD.

## Cirrus Airplane Parachute System

The SR22 is equipped with a Cirrus Airplane Parachute System (CAPS) designed to bring the aircraft and its occupants to the ground in the event of a life-threatening emergency. The system is intended to save the lives of the occupants but will most likely destroy the aircraft and may, in adverse circumstances, cause serious injury or death to the occupants. Because of this it is important to carefully read the CAPS descriptions in this section, section 3 Emergency Procedures and Section 10, Safety and consider when and how you would use the system.

### • WARNING •

The parachute system does not require electrical power for activation and can be activated at any time. The solid-propellant rocket flight path is upward from the parachute cover. Stay clear of parachute canister area when aircraft is occupied. Do not allow children in the aircraft unattended.

### System Description

The CAPS consists of a parachute, a solid-propellant rocket to deploy the parachute, a rocket activation handle, and a harness imbedded within the fuselage structure.

A composite box containing the parachute and solid-propellant rocket is mounted to the airplane structure immediately aft of the baggage compartment bulkhead. The box is covered and protected from the elements by a thin composite cover.

The parachute is enclosed within a deployment bag that stages the deployment and inflation sequence. The deployment bag creates an orderly deployment process by allowing the canopy to inflate only after the rocket motor has pulled the parachute lines taut.

The parachute itself is a 2400-square-foot round canopy equipped with a slider, an annular-shaped fabric panel with a diameter significantly less than the open diameter of the canopy. The slider has grommets spaced around its perimeter. The canopy suspension lines are routed through these grommets so that the slider is free to move along the suspension lines. Since the slider is positioned at the top of the suspension lines near the canopy, at the beginning of the deployment

sequence the slider limits the initial diameter of the parachute and the rate at which the parachute inflates. As the slider moves down the suspension lines the canopy inflates.

A three-point harness connects the airplane fuselage structure to the parachute. The aft harness strap is stowed in the parachute canister and attached to the structure at the aft baggage compartment bulkhead. The forward harness straps are routed from the canister to firewall attach points just under the surface of the fuselage skin. When the parachute deploys, the forward harness straps pull through the fuselage skin covering from the canister to the forward attach points.

## Activation Handle

CAPS is initiated by pulling the CAPS Activation T-handle installed in the cabin ceiling on the airplane centerline just above the pilot's right shoulder. A placarded cover, held in place with hook and loop fasteners, covers the T-handle and prevents tampering with the control. The cover is removed by pulling the black tab at the forward edge of the cover.

Pulling the activation T-handle will activate the rocket and initiate the CAPS deployment sequence. To activate the rocket, two separate events must occur:

1. Pull the activation T-handle from its receptacle. Pulling the T-handle removes it from the o-ring seal that holds it in place and takes out the slack in the cable (approximately two inches (5 cm) of cable will be exposed). Once the slack is removed, the T-handle motion will stop and greater force will be required to activate the rocket.
2. Clasp both hands around activation T-handle and pull straight downward with a strong, steady, and continuous force until the rocket activates. A chin-up type pull works best. Up to 45.0 pounds (20.4 Kg) force, or greater, may be required to activate the rocket. The greater force required occurs as the cable arms and then releases the rocket igniter firing pin. When the firing pin releases, two primers discharge and ignite the rocket fuel.

• Note •

Jerking or rapidly pulling on the activation T-handle greatly increases the pull forces required to activate the rocket.

Attempting to activate the rocket by pushing the activation T-handle forward and down limits the force that can be applied. Pulling the activation T-handle straight down generates the greatest force.

A maintenance safety pin is provided to ensure that the activation handle is not pulled during maintenance. However, there may be some circumstances where an operator may wish to safety the CAPS system; for example, the presence of unattended children in the airplane, the presence of people who are not familiar with the CAPS activation system in the airplane, or during display of the airplane.

The pin is inserted through the handle retainer and barrel locking the handle in the “safe” position. A “Remove Before Flight” streamer is attached to the pin.

• **WARNING** •

After maintenance has been performed or any other time the system has been safetied, operators must verify that the pin has been removed before further flight.

## Deployment Characteristics

When the rocket launches, the parachute assembly is extracted outward due to rocket thrust and rearward due to relative wind. In approximately two seconds the parachute will begin to inflate.

When air begins to fill the canopy, forward motion of the airplane will dramatically be slowed. This deceleration increases with airspeed but in all cases within the parachute envelope should be less than 3 g's. During this deceleration a slight nose-up may be experienced, particularly at high speed; however, the rear riser is intentionally snubbed short to preclude excessive nose-up pitch. Following any nose-up pitching, the nose will gradually drop until the aircraft is hanging nose-low beneath the canopy.

Eight seconds after deployment, the rear riser snub line will be cut and the aircraft tail will drop down into its final approximately level attitude. Once stabilized in this attitude, the aircraft may yaw slowly back and forth or oscillate slightly as it hangs from the parachute. Descent rate is expected to be less than 1700 feet per minute with a lateral speed



equal to the velocity of the surface wind. In addition, surface winds may continue to drag the aircraft after ground impact.

• **Caution** •

Ground impact is expected to be equivalent to touchdown from a height of approximately 13 feet. While the airframe, seats and landing gear are designed to accommodate this stress, occupants must prepare for it in accordance with the CAPS Deployment procedure in Section 3 - Emergency Procedures.

• **Note** •

The CAPS is designed to work in a variety of aircraft attitudes, including spins. However, deployment in an attitude other than level flight may yield deployment characteristics other than those described above.

Intentionally Left Blank

# **Section 8**

## **Handling, Servicing, Maintenance**

### **Table of Contents**

Introduction .....	8-3
Operator's Publications .....	8-3
Service Publications .....	8-3
Ordering Publications .....	8-4
Airplane Records and Certificates .....	8-5
Airworthiness Directives .....	8-6
Airplane Inspection Periods .....	8-7
Pilot Performed Preventative Maintenance .....	8-8
Ground Handling .....	8-10
Application of External Power .....	8-10
Towing .....	8-11
Taxiing .....	8-12
Parking .....	8-13
Tiedown .....	8-14
Leveling .....	8-14
Jacking .....	8-15
Servicing .....	8-16
Landing Gear Servicing .....	8-16
Brake Servicing .....	8-16
Tire Inflation .....	8-17
Propeller Servicing .....	8-17
Oil Servicing .....	8-18
Fuel System Servicing .....	8-21
Fuel Contamination and Sampling .....	8-23
Draining Fuel System .....	8-23
Battery Service .....	8-24
Cleaning and Care .....	8-25
Cleaning Exterior Surfaces .....	8-25
Windscreen and Windows .....	8-26
Engine Compartment .....	8-27
Landing Gear .....	8-28
Cleaning Interior Surfaces .....	8-30
Windshield and Windows .....	8-30

**Section 8**  
**Handling, Servicing, Maintenance**

**Cirrus Design**  
**SR22**

Instrument Panel and Electronic Display Screens .....8-31  
Headliner and Trim Panels .....8-31  
Leather Upholstery and Seats .....8-32  
Carpets .....8-32

## Introduction

This section provides general guidelines for handling, servicing and maintaining your Cirrus Design SR22. In order to ensure continued safe and efficient operation of your airplane, keep in contact with your Authorized Cirrus Service Center to obtain the latest information pertaining to your aircraft.

## Operator's Publications

The FAA Approved Airplane Flight Manual and Pilot's Operating Handbook (POH) is provided at delivery. Additional or replacement copies may be obtained from Cirrus Design by contacting the Customer Service Department.

## Service Publications

The following service publications are available for purchase from Cirrus Design for the SR22:

- Airplane Maintenance Manual (AMM) – GAMA-type Maintenance Manual divided into chapters as specified by GAMA and ATA covering inspection, servicing, maintenance, troubleshooting, and repair of the airplane structure, systems, and wiring. Revision Service for this manual is also available. A current copy of the AMM is provided at delivery.
- Engine Operators and Maintenance Manual – Cirrus Design provides a Teledyne Continental Engine Operator's and Maintenance Manual at the time of delivery. Engine and engine accessory overhaul manuals can be obtained from the original equipment manufacturer.
- Avionics Component Operator and Maintenance Manuals – Cirrus Design provides all available operator's manuals at the time of delivery. Maintenance manuals, if available, may be obtained from the original equipment manufacturer.

Cirrus Design offers a Subscription Service for the Service Bulletins, Service Letters and Options Letters issued from the factory. This service is offered to interested persons such as owners, pilots and mechanics at a nominal fee. Interested parties may obtain copies and subscription service for these documents by contacting Customer Service at Cirrus Design.

- Service Bulletins – -are of special importance. When you receive a Service Bulletin, comply with it promptly.
- Service Advisory Notices – are used to notify you of optional Service Bulletins, supplier Service Bulletins or Service Letters affecting your airplane, and maintenance data or corrections not requiring a Service Bulletin. Give careful attention to the Service Advisory Notice information.

## **Ordering Publications**

SR22 publications, revision service, and service publication subscription service may be obtained by contacting Customer Service at Cirrus Design as follows:

Cirrus Design Corporation  
Customer Service  
4515 Taylor Circle  
Duluth, MN 55811  
Phone: 218 727-2737  
FAX: 218 727-2148

Make sure to include airplane serial number and owner's name in all correspondence for accurate processing of your documentation needs.

## Airplane Records and Certificates

The Federal Aviation Administration (FAA) requires that certain data, certificates, and licenses be displayed or carried aboard the airplane at all times. Additionally, other documents must be made available upon request. The mnemonic acronym “ARROW” is often used to help remember the required documents.

• Note •

Owners of aircraft not registered in the United States should check with the registering authority for additional requirements.

Required Documents		Note
<b>A</b>	Airworthiness Certificate <i>FAA Form 8100-2</i>	Must be displayed at all times
<b>R</b>	Registration Certificate <i>FAA Form 8050-3</i>	Must be in the aircraft for all operations.
<b>R</b>	Radio Station License <i>FCC Form 556</i>	Required only for flight operations outside the United States
<b>O</b>	Operating Instructions	FAA Approved Flight Manual and Pilot's Operating Handbook fulfills this requirement
<b>W</b>	Weight & Balance Data	Included in FAA Approved Airplane Flight Manual and Pilot's Operating Handbook. Data must include current empty weight, CG, and equipment list.

Other Documents		Note
Airplane Logbook		Must be made available upon request
Engine Logbook		Must be made available upon request
Pilot's Checklist		Available in cockpit at all times.

## **Airworthiness Directives**

The Federal Aviation Administration (FAA) publishes Airworthiness Directives (AD's) that apply to specific aircraft and aircraft appliances or accessories. AD's are mandatory changes and must be complied with within a time limit set forth in the AD. Operators should periodically check with Cirrus Service Centers or A&P mechanic to verify receipt of the latest issued AD for their airplane.



## Airplane Inspection Periods

FAR 91.409 requires that all aircraft must undergo a thorough annual inspection meeting the requirements of FAR 43. Annual inspections are based upon calendar months and are due on the last day of the twelfth month following the last annual inspection. For example: If an annual inspection were performed on 19 November 1998, the next annual inspection will be due 30 November 1999. Annual inspections must be accomplished regardless of the number of hours flown the previous year and can only be performed by a licensed Airframe and Powerplant (A&P) mechanic holding an Inspection Authorization (IA). All Cirrus Authorized Service Centers can perform annual inspections. The inspection is listed, in detail, in Chapter 5 of the Cirrus Design SR22 Maintenance Manual.

If the airplane is used commercially, in addition to the annual inspection requirement, the regulation requires that the airplane undergo a 100-hour inspection each 100 hours of flight operation. The scope of the 100-hour inspection is identical to the annual inspection except that it can be accomplished by a licensed A&P mechanic. The 100-hour interval may be exceeded by not more than 10 flight hours in order to reach a place where the inspection can be accomplished. Any flight hours used to reach an inspection station must be deducted from the next 100-hour inspection interval.

## Pilot Performed Preventative Maintenance

The holder of a Pilot Certificate issued under FAR Part 61 may perform certain preventive maintenance described in FAR Part 43, Appendix A. This maintenance may be performed only on an aircraft that the pilot owns or operates and which is not used in air carrier service. The regulation also stipulates that the pilot must also complete the appropriate logbook entries. The following is a list of the maintenance that the pilot may perform:

• Note •

The pilot should have the ability and manual procedures for the work to be accomplished.

The pilot may not accomplish any work involving the removal or disassembly of primary structure or operating system, or interfere with an operating system, or affect the primary structure.

- Remove, install, and repair tires.
- Clean, grease, or replace wheel bearings
- Replace defective safety wire or cotter pins.
- Lubrication not requiring disassembly other than removal of nonstructural items such as access covers, cowlings, or fairings.
- Replenish hydraulic fluid in the hydraulic and brake reservoirs.
- Refinish the airplane interior or exterior (excluding balanced control surfaces) with protective coatings.
- Repair interior upholstery and furnishings.
- Replace side windows.
- Replace safety belts, seats, or seat parts with replacement parts approved for the aircraft.
- Replace bulbs, reflectors and lenses of position and landing lights.
- Replace cowling not requiring removal of the propeller.
- Replace, clean or set spark plug gap clearance.
- Replace any hose connection, except hydraulic connections, with replacement hoses.

- Clean or replace fuel and oil strainers, as well as replace or clean filter elements.
- Replace prefabricated fuel lines.
- Replace the battery and check fluid level and specific gravity.

### ***Logbook Entry***

After any of the above work is accomplished, appropriate logbook entries must be made. Logbook entries should contain:

- The date the work was accomplished.
- Description of the work.
- Number of hours on the aircraft.
- The certificate number of pilot performing the work.
- Signature of the individual doing the work.

Logbooks should be complete and up to date. Good records reduce maintenance cost by giving the mechanic information about what has or has not been accomplished.

## Ground Handling

### Application of External Power

A ground service receptacle, located just aft of the cowl on the left side of the airplane, permits the use of an external power source for cold weather starting and maintenance procedures.

#### • WARNING •

If external power will be used to start engine, keep yourself, others, and power unit cables well clear of the propeller rotation plane.

#### *To apply external power to the airplane:*

##### • Caution •

Do not use external power to start the airplane with a 'dead' battery or to charge a dead or weak battery in the airplane. The battery must be removed from the airplane and battery maintenance performed in accordance with the appropriate Airplane Maintenance Manual procedures.

1. Ensure that external power source is regulated to 28 VDC.
2. Check BAT and AVIONICS power switches are 'off.'
3. Plug external power source into the receptacle.
4. Set BAT 1 switch to ON. 28 VDC from the external power unit will energize the main distribution and essential distribution buses. The airplane may now be started or electrical equipment operated.
5. If avionics are required, set AVIONICS power switch ON.

##### • Caution •

If maintenance on avionics systems is to be performed, it is recommended that external power be used. Do not start or crank the engine with the AVIONICS power switch 'on.'

#### *To remove external power from airplane:*

1. If battery power is no longer required, set BAT 1 switch 'off.'
2. Pull external power source plug.

## Towing

The airplane may be moved on the ground by the use of the nose wheel steering bar that is stowed in the rear baggage compartment or by power equipment that will not damage or excessively strain the nose gear assembly. The steering bar is engaged by inserting it into lugs just forward of the nose wheel axle.

### • Caution •

While pushing the aircraft backward, the tow bar must be installed to keep the nose wheel from turning abruptly.

Do not use the vertical or horizontal control surfaces or stabilizers to move the airplane. If a tow bar is not available, use the wing roots as push points.

Do not push or pull on control surfaces or propeller to maneuver the airplane.

Do not tow the airplane when the main gear is obstructed with mud or snow.

If the airplane is to be towed by vehicle, do not turn the nose wheel more than 90 degrees either side of center or structural damage to the nose gear could result.

1. Refer to *Airplane Three View (Section 1, Figure 1-1)* and *Turning Radius (Section 1, Figure 1-2)* or clearances. Be especially cognizant of hangar door clearances.
2. Insert tow bar into the lugs just forward of the nose wheel axle.
3. Release parking brake and remove chocks
4. Move airplane to desired location.
5. Install chocks
6. Remove tow bar.

To obtain a minimum radius turn during ground handling, the airplane may be rotated around either main landing gear by pressing down on a fuselage just forward of the horizontal stabilizer to raise the nosewheel off the ground.

## Taxiing

Before attempting to taxi the airplane, ground personnel should be instructed and authorized by the owner to taxi the airplane. Instruction should include engine starting and shutdown procedures in addition to taxi and steering techniques.

### • Caution •

Verify that taxi and propeller wash areas are clear before beginning taxi.

Do not operate the engine at high RPM when running up or taxiing over ground containing loose stones, gravel, or any loose material that may cause damage to the propeller blades.

Taxi with minimum power needed for forward movement. Excessive braking may result in overheated or damaged brakes.

1. Remove chocks.
2. Start engine in accordance with Starting Engine procedure (Section 4).
3. Release parking brake.
4. Advance throttle to initiate taxi. Immediately after initiating taxi, apply the brakes to determine their effectiveness. During taxiing, use differential braking to make slight turns to ascertain steering effectiveness.

### • Caution •

Observe wing clearance when taxiing near buildings or other stationary objects. If possible, station an observer outside the airplane.

Avoid holes and ruts when taxiing over uneven ground.

5. Taxi airplane to desired location.
6. Shut down airplane and install chocks and tie-downs in accordance with Shutdown procedure (Section 4).

## Parking

The airplane should be parked to protect the airplane from weather and to prevent it from becoming a hazard to other aircraft. The parking brake may release or exert excessive pressure because of heat buildup after heavy braking or during wide temperature swings. Therefore, if the airplane is to be left unattended or is to be left overnight, chock and tie down the airplane.

1. For parking, head airplane into the wind if possible.
2. Retract flaps.
3. Set parking brake by first applying brake pressure using the toe brakes and then pulling the PARK BRAKE knob aft.

### • Caution •

Care should be taken when setting overheated brakes or during cold weather when accumulated moisture may freeze a brake.

4. Chock both main gear wheels.
5. Tie down airplane in accordance with tiedown procedure in this section.
6. Install a pitot head cover. Be sure to remove the pitot head cover before flight.
7. Cabin and baggage doors should be locked when the airplane is unattended.

## Tiedown

The airplane should be moored for immovability, security and protection. FAA Advisory Circular AC 20-35C, Tiedown Sense, contains additional information regarding preparation for severe weather, tiedown, and related information. The following procedures should be used for the proper mooring of the airplane:

1. Head the airplane into the wind if possible.
2. Retract the flaps.
3. Chock the wheels.
4. Secure tie-down ropes to the wing tie-down rings and to the tail ring at approximately 45-degree angles to the ground. When using rope or non-synthetic material, leave sufficient slack to avoid damage to the airplane should the ropes contract.

### • Caution •

Anchor points for wing tiedowns should not be more than 18 feet apart to prevent eyebolt damage in heavy winds.

Use bowline knots, square knots, or locked slipknots. Do not use plain slipknots.

## Leveling

The airplane is leveled longitudinally by means of a spirit level placed on the pilot door sill and laterally by means of a spirit level placed across the door sills. Alternately, sight the forward and aft tool holes along waterline 95.9 to level airplane. *Refer to Section 6, Airplane Weighing Procedures and Section 6, Figure 6-2, for illustration.*



## Jacking

Two jacking points are provided: one at each wing tiedown. Jack points (pads) are stowed in the baggage compartment. The airplane may be jacked using two standard aircraft hydraulic jacks at the wing jacking points and a weighted tailstand attached to the tail tiedown.

### ***Raise Airplane***

#### • Caution •

Do not jack the aircraft outside or in open hangar with winds in excess of 10 mph.

The empty CG is forward of the wing jacking points. To prevent airplane from tipping forward during maintenance or jacking, use a weighted tailstand (300-lb minimum) attached to the tail tiedown.

1. Position airplane on a hard, flat, level surface.
2. Remove tiedown rings from wings. Stow tie-down rings in baggage compartment.
3. Attach a weighted tailstand to the tail tiedown ring.
4. Position jacks and jack points (pads) for jacking. Insert jack point (pad) into wing tiedown receptacle. Holding the jack point (pad) in place, position the jack under the point and raise the jack to firmly contact the jack point. Repeat for opposite jacking point.
5. Raise the airplane keeping the airplane as level as possible.
6. Secure jack locks.

### ***Lower Airplane***

1. Release pressure on all jacks as simultaneously as necessary to keep airplane as level as possible.
2. Remove jacks, jack points (pads), and tailstand. Stow points in baggage compartment. Install tiedown rings in wings.

## Servicing

### Landing Gear Servicing

The main landing gear wheel assemblies use 15 x 6.00 x 6, six-ply rating tires and tubes. The nose wheel assembly uses a 5.00 x 5 four-ply rating, type III tire and tube. Always keep tires inflated to the rated pressure to obtain optimum performance and maximum service. The landing gear struts do not require servicing. With the exception of replenishing brake fluid, wheel and brake servicing must be accomplished in accordance with Airplane Maintenance Manual (AMM) procedures.

### Brake Servicing

#### ***Brake Replenishing***

The brake system is filled with MIL-H-5606 hydraulic brake fluid. The fluid level should be checked at every oil change and at the annual/100-hour inspection, replenishing the system when necessary. The brake reservoir is located on the right side of the battery support frame. If the entire system must be refilled, *refer to the Airplane Maintenance Manual (AMM)*.

To replenish brake fluid:

1. Chock tires and release parking brake.
2. Remove top engine cowling to gain access to hydraulic fluid reservoir.
3. Clean reservoir cap and area around cap before opening reservoir cap.
4. Remove cap and add MIL-H-5606 hydraulic fluid as necessary to fill reservoir.
5. Install cap, inspect area for leaks, and then install and secure engine cowling.

#### ***Brake Lining Inspection***

The brake linings should be checked at every oil change and at the annual/100-hour inspection.

To inspect the brake linings:

1. Remove main landing gear fairings.

2. Check brake linings for deterioration and maximum permissible wear. Replace lining when worn to 0.100 inch (2.54 mm).
3. Install main landing gear fairings.

## Tire Inflation

For maximum service from the tires, keep them inflated to the proper pressure. Nose tire unloaded tire pressure is 40 +2/-0 psi (275 +15/-0 kPa) and the unloaded main gear tire pressure is 62 +2/-0 psi (427 +15/-0 kPa). When checking tire pressure, examine the tires for wear, cuts, nicks, bruises and excessive wear.

To inflate tires:

1. Remove inspection buttons on wheel pants to gain access to valve stems. It may be necessary to move airplane to get valve stem aligned with the access hole.
2. Remove valve stem cap and verify tire pressure with a dial-type tire pressure gage.
3. Inflate nose tire to 40 +2/-0 psi (276 +15/-0 kPa) and main wheel tires to 62 +2/-0 psi (427 +15/-0 kPa).
4. Replace valve stem cap and inspection buttons.

All wheels and tires are balanced before original installation and the relationship of tire, tube, and wheel should be maintained upon reinstallation. In the installation of new components, it may be necessary to rebalance the wheels with the tires mounted. Unbalanced wheels can cause extreme vibration in the landing gear.

## Propeller Servicing

The spinner and backing plate should be cleaned and inspected for cracks frequently. Before each flight the propeller should be inspected for nicks, scratches, and corrosion. If found, they should be repaired as soon as possible by a rated mechanic, since a nick or scratch causes an area of increased stress which can lead to serious cracks or the loss of a propeller tip. The back face of the blades should be painted when necessary with flat black paint to retard glare. To prevent corrosion, the surface should be cleaned and waxed periodically.

## Oil Servicing

The oil capacity of the Teledyne Continental IO-550-N engine is 8 quarts. It is recommended that the oil be changed every 50 hours and sooner under unfavorable operating conditions. The following grades are recommended for the specified temperatures at sea level (SL):

Ambient Air Temperature (SL)	Single Viscosity	Multi-Viscosity
All Temperatures	—	20W-60 20W-50 15W-50
Below 40° F	SAE 30	10W-30 20W-60 20W-50 15W-50
Above 40° F	SAE 50	20W-60 20W-50 15W-50

An oil filler cap and dipstick are located at the left rear of the engine and are accessible through an access door on the top left side of the engine cowling. The engine should not be operated with less than six quarts of oil. Seven quarts (dipstick indication) is recommended for extended flights.

To check and add oil:

1. Open access door on upper left-hand side of cowl. Pull dipstick and verify oil level.
2. If oil level is below 6 quarts (5.7 liters), remove filler cap and add oil through filler as required to reach 7-8 quarts (6.6-7.6 liters).
3. Verify oil level and install dipstick and filler cap.
4. Close and secure access panel.

### ***Approved Oils***

For the first 25 hours of operation (on a new or rebuilt engine) or until oil consumption stabilizes, use only straight mineral oil conforming to Mil-L-6082. If engine oil must be added to the factory installed oil, add only MIL-L-6082 straight mineral oil.

**• Caution •**

MIL-C-6529, Type II straight mineral oil with corrosion preventive can cause coking with extended use and is not recommended by Cirrus Design for break-in or post break-in use.

After 25 hours of operation and after oil consumption has stabilized, use only aviation lubricating oils conforming to Teledyne Continental Motors (TCM) Specification MHS24, Lubricating Oil, Ashless Dispersant, or TCM Specification MHS25, Synthetic Lubrication Oil.

<b>Product</b>	<b>Supplier</b>
Aeroshell (R) W	Shell Australia
Aeroshell Oil W Aeroshell Oil W 15W-50 Anti-Wear Formulation Aeroshell 15W50	Shell Canada Ltd.
Aeroshell Oil W Aeroshell Oil W 15W-50 Anti-Wear Formulation Aeroshell 15W50	Shell Oil Company
Aviation Oil Type A	Phillips 66 Company
BP Aero Oil	BP Oil Corporation
Castrolaero AD Oil	Castrol Ltd. (Australia)
Chevron Aero Oil	Chevron U.S.A. Inc.
Conoco Aero S	Continental Oil
Delta Avoil	Delta Petroleum Co.
Exxon Aviation Oil EE	Exxon Company, U.S.A.
Mobil Aero Oil	Mobil Oil Company
Pennzoil Aircraft Engine Oil	Pennzoil Company
Quaker State AD Aviation Engine Oil	Quaker State Oil & Refining Co.
Red Ram Aviation Oil 20W-50	Red Ram Ltd. (Canada)
Sinclair Avoil	Sinclair Oil Company
Texaco Aircraft Engine Oil – Premium AD	Texaco Inc.
Total Aero DW 15W50	Total France
Turbonycoil 3570	NYCO S.A.
Union Aircraft Engine Oil HD	Union Oil Company of California

**Figure 8-1**  
**Approved Oils**

## Fuel System Servicing

At every 100-hours of operation, the fuel filtration screen in the gascolator must be cleaned. After cleaning, a small amount of grease applied to the gascolator bowl gasket will facilitate reassembly.

### ***Fuel Requirements***

Aviation grade 100 LL (blue) or 100 (green) fuel is the minimum octane approved for use in this airplane.

#### **• Caution •**

Use of lower grades can cause serious engine damage in a short period. The engine warranty is invalidated by the use of lower octane fuels.

### ***Filling Fuel Tanks***

Observe all safety precautions required when handling gasoline. Fuel fillers are located on the forward slope of the wing. Each wing holds a maximum of 40.5 U.S. gallons. When using less than the standard 81.0 U.S. gallon capacity, fuel should be distributed equally between each side.

#### **• WARNING •**

Have a fire extinguisher available.

Ground fuel nozzle and fuel truck to airplane exhaust pipe and ground fuel truck or cart to suitable earth ground.

Do not fill tank within 100 feet (30.5 meters) of any energized electrical equipment capable of producing a spark.

Permit no smoking or open flame within 100 feet (30.5 meters) of airplane or refuel vehicle.

Do not operate radios or electrical equipment during refuel operations. Do not operate any electrical switches.

To refuel airplane:

1. Place fire extinguisher near fuel tank being filled.
2. Connect ground wire from refuel nozzle to airplane exhaust, from airplane exhaust to fuel truck or cart, and from fuel truck or cart to a suitable earth ground.

3. Place rubber protective cover over wing around fuel filler.

• Note •

Do not permit fuel nozzle to come in contact with bottom of fuel tanks. Keep fuel tanks at least half full at all times to minimize condensation and moisture accumulation in tanks. In extremely humid areas, the fuel supply should be checked frequently and drained of condensation to prevent possible distribution problems.

4. Remove fuel filler cap and fuel airplane to desired level.

• Note •

If fuel is going to be added to only one tank, the tank being serviced should be filled to the same level as the opposite tank. This will aid in keeping fuel loads balanced.

5. Remove nozzle, install filler cap, and remove protective cover.
6. Repeat refuel procedure for opposite wing.
7. Remove ground wires.
8. Remove fire extinguisher.



## Fuel Contamination and Sampling

Typically, fuel contamination results from foreign material such as water, dirt, rust, and fungal or bacterial growth. Additionally, chemicals and additives that are incompatible with fuel or fuel system components are also a source of fuel contamination. To assure that the proper grade of fuel is used and that contamination is not present, **the fuel must be sampled prior to each flight.**

Each fuel system drain must be sampled by draining a cupful of fuel into a clear sample cup. Fuel drains are provided for the fuel gascolator, wing tanks, and collector tank drains. The gascolator drain exits the lower engine cowl just forward of the firewall near the airplane centerline. Fuel tank and collector tank drains are located at the low spot in the respective tank.

If sampling reveals contamination, the gascolator and tank drains must be sampled again repeatedly until all contamination is removed. It is helpful to gently rock the wings and lower the tail slightly to move contaminants to the drain points for sampling. If after repeated samplings (three or more), evidence of significant contamination remains, do not fly the airplane until a mechanic is consulted, the fuel system is drained and purged, and the source of contamination is determined and corrected.

If sampling reveals the airplane has been serviced with an improper fuel grade, do not fly the airplane until the fuel system is drained and refueled with an approved fuel grade.

To help reduce the occurrence of contaminated fuel coming from the supplier or fixed based operator, pilots should assure that the fuel supply has been checked for contamination and that the fuel is properly filtered. Also, between flights, the fuel tanks should be kept as full as operational conditions permit to reduce condensation on the inside of fuel tanks.

## Draining Fuel System

The bulk of the fuel may be drained from the wing fuel tanks by the use of a siphon hose placed in the cell or tank through the filler neck. The remainder of the fuel may be drained by opening the drain valves. Use the same precautions as when refueling airplane. *Refer to the SR22 Maintenance Manual* for specific procedures.

## Battery Service

Battery #1 is mounted to the forward right side of the firewall and access is gained by removing the upper cowl. The battery vent is connected to an acid resistant plastic tube that vents gases and electrolyte overflow overboard. Battery #2 is located behind the baggage compartment aft bulkhead below the parachute canister. Battery #2 consists of two sealed, maintenance-free units and is not considered pilot serviceable.

Battery #1 fluid level must not be brought above the baffle plates. Until experience indicates a longer interval is justified, the battery should be checked every 30 days or 25 flight hours to determine that the fluid level is proper and the connections are tight and free of corrosion. Do not fill the battery with acid use distilled water only. If the battery is not properly charged, recharge it starting with a rate of four amperes and finishing with a rate of two amperes in accordance with Airplane Maintenance Manual (AMM) procedures. The battery should be removed from the airplane for charging, and quick charges are not recommended.

Battery 2 is a maintenance free, rechargeable, sealed, lead acid batter. Mounted in the empennage just aft of bulkhead 222, there is no need to check the specific gravity of the electrolyte or add water to these batteries during their service life. *Refer to the Airplane Maintenance Manual (AMM) for Overhaul and Replacement Schedule.*

The external power receptacle is located on the left side of the fuselage just aft of the firewall. *Refer to the Airplane Maintenance Manual (AMM) for battery servicing procedures.*

## Cleaning and Care

### Cleaning Exterior Surfaces

• Caution •

*Airplane serials 0334 and subsequent with Ice Protection System; Do not wax leading edge porous panels. Refer to Section 9, Supplements for specific servicing information on the Ice Protection System.*

• Note •

Prior to cleaning, place the airplane in a shaded area to allow the surfaces to cool.

The airplane should be washed with a mild soap and water. Harsh abrasives or alkaline soaps or detergents could make scratches on painted or plastic surfaces or could cause corrosion of metal. Cover areas where cleaning solution could cause damage. To wash the airplane, use the following procedure:

1. Flush away loose dirt with water.
2. Apply cleaning solution with a soft cloth, a sponge or a soft bristle brush.
3. To remove exhaust stains, allow the solution to remain on the surface longer.
4. To remove stubborn oil and grease, use a cloth dampened with naphtha.
5. Rinse all surfaces thoroughly.

Any good silicone free automotive wax may be used to preserve painted surfaces. Soft cleaning cloths or a chamois should be used to prevent scratches when cleaning or polishing. A heavier coating of wax on the leading surfaces will reduce the abrasion problems in these areas.

## Windscreen and Windows

Before cleaning an acrylic window, rinse away all dirt particles before applying cloth or chamois. Never rub dry acrylic. Dull or scratched window coverings may be polished using a special acrylic polishing paste.

• **Caution** •

Use only clean acrylic windows with a solvent free, none abrasive, antistatic acrylic cleaner. Do not use gasoline, alcohol, benzene, carbon tetrachloride, thinner, acetone, or glass window cleaning sprays.

Use only a nonabrasive cotton cloth or genuine chamois to clean acrylic windows. Paper towel or newspaper are highly abrasive and will cause hairline scratches.

1. Remove grease or oil using a soft cloth saturated with kerosene then rinse with clean, fresh water.

• **Note** •

Wiping with a circular motion can cause glare rings. Use an up and down wiping motion to prevent this.

To prevent scratching from dirt that has accumulated on the cloth, fold cloth to expose a clean area after each pass.

2. Using a moist cloth or chamois, gently wipe the windows clean of all contaminants.
3. Apply acrylic cleaner to one area at a time, then wipe away with a soft, cotton cloth.
4. Dry the windows using a dry nonabrasive cotton cloth or chamois.

## Engine Compartment

Before cleaning the engine compartment, place a strip of tape on the magneto vents to prevent any solvent from entering these units.

1. Place a large pan under the engine to catch waste.
2. Remove induction air filter and seal off induction system inlet.
3. With the engine cowling removed, spray or brush the engine with solvent or a mixture of solvent and degreaser. In order to remove especially heavy dirt and grease deposits, it may be necessary to brush areas that were sprayed.

**• Caution •**

Do not spray solvent into the alternator, vacuum pump, starter, or induction air intakes.

4. Allow the solvent to remain on the engine from 5 to 10 minutes. Then rinse engine clean with additional solvent and allow it to dry.

**• Caution •**

Do not operate the engine until excess solvent has evaporated or otherwise been removed

5. Remove the protective tape from the magnetos.
6. Open induction system air inlet and install filter.
7. Lubricate the controls, bearing surfaces, etc., in accordance with the Lubrication Chart.

## **Landing Gear**

Before cleaning the landing gear, place a plastic cover or similar material over the wheel and brake assembly.

1. Place a pan under the gear to catch waste.
2. Spray or brush the gear area with solvent or a mixture of solvent and degreaser, as desired. Where heavy grease and dirt deposits have collected, it may be necessary to brush areas that were sprayed, in order to clean them.
3. Allow the solvent to remain on the gear from five to ten minutes. Then rinse the gear with additional solvent and allow to dry.
4. Remove the cover from the wheel and remove the catch pan.
5. Lubricate the gear in accordance with the Lubrication Chart.

<b>Cleaning Product</b>	<b>Cleaning Application</b>	<b>Supplier</b>
Mild Dishwasher Soap (abrasive free)	Fuselage Exterior and Landing Gear	Any Source
Pure Carnauba Wax	Fuselage Exterior	Any Source
Mothers California Gold Pure Carnauba Wax	Fuselage Exterior	Wal-Mart Stores
RejeX	Fuselage Exterior	Corrosion Technologies
WX/Block System	Fuselage Exterior	Wings and Wheels
AeroShell Flight Jacket Plexicoat	Fuselage Exterior	ShellStore Online
XL-100 Heavy-Duty Cleaner/Degreaser	Fuselage Exterior and Landing Gear	Buckeye International
Stoddard Solvent PD-680 Type II	Engine Compartment	Any Source
Kerosene	Exterior Windscreen and Windows	Any Source
Klear-To-Land	Exterior Windscreen and Windows	D.W. Davies & Co
Prist	Exterior Windscreen and Windows	Prist Aerospace
LP Aero Plastics Acrylic Polish & Sealant	Exterior Windscreen and Windows	Aircraft Spruce & Specialty

**Figure 8-2**  
**Recommended Exterior Cleaning Products**

## Cleaning Interior Surfaces

Seats, carpet, upholstery panels, and headliners should be vacuumed at regular intervals to remove surface dirt and dust. While vacuuming, use a fine bristle nylon brush to help loosen particles.

• **Caution** •

Remove any sharp objects from pockets or clothing to avoid damaging interior panels or upholstery.

## Windshield and Windows

Never rub dry acrylic. Dull or scratched window coverings may be polished using a special acrylic polishing paste.

• **Caution** •

Use only clean acrylic windows with a solvent free, none abrasive, antistatic acrylic cleaner. Do not use gasoline, alcohol, benzene, carbon tetrachloride, thinner, acetone, or glass window cleaning sprays.

Use only a nonabrasive cotton cloth or genuine chamois to clean acrylic windows. Paper towel or newspaper are highly abrasive and will cause hairline scratches.

• **Note** •

Wiping with a circular motion can cause glare rings. Use an up and down wiping motion to prevent this.

To prevent scratching from dirt that has accumulated on the cloth, fold cloth to expose a clean area after each pass.

1. Using a moist cloth or chamois, gently wipe the windows clean of all contaminants.
2. Apply acrylic cleaner to one area at a time, then wipe away with a soft, cotton cloth.
3. Dry the windows using a dry nonabrasive cotton cloth or chamois.



## Instrument Panel and Electronic Display Screens

The instrument panel, control knobs, and plastic trim need only to be wiped clean with a soft damp cloth. The multifunction display, primary flight display, and other electronic display screens should be cleaned with Optimax - LCD Screen Cleaning Solution as follows:

### • Caution •

To avoid solution dripping onto display and possibly migrating into component, apply the cleaning solution to cloth first, not directly to the display screen.

Use only a lens cloth or nonabrasive cotton cloth to clean display screens. Paper towels, tissue, or camera lens paper may scratch the display screen.

Clean display screen with power OFF.

1. Gently wipe the display with a clean, dry, cotton cloth.
2. Moisten clean, cotton cloth with cleaning solution.
3. Wipe the soft cotton cloth across the display in one direction, moving from the top of the display to the bottom. Do not rub harshly.
4. Gently wipe the display with a clean, dry, cotton cloth.

## Headliner and Trim Panels

The airplane interior can be cleaned with a mild detergent or soap and water. Harsh abrasives or alkaline soaps or detergents should be avoided. Solvents and alcohols may damage or discolor vinyl or urethane parts. Cover areas where cleaning solution could cause damage. Use the following procedure:

### • Caution •

Solvent cleaners and alcohol should not be used on interior parts. If cleaning solvents are used on cloth, cover areas where cleaning solvents could cause damage.

1. Clean headliner, and side panels, with a stiff bristle brush, and vacuum where necessary.

2. Soiled upholstery, may be cleaned with a good upholstery cleaner suitable for the material. Carefully follow the manufacturer's instructions. Avoid soaking or harsh rubbing.

## Leather Upholstery and Seats

For routine maintenance, occasionally wipe leather upholstery with a soft, damp cloth. For deeper cleaning, start with mix of mild detergent and water then, if necessary, work your way up to the products available from Cirrus for more stubborn marks and stains. Do not use soaps as they contain alkaline which will alter the leather's pH balance and cause the leather to age prematurely. Cover areas where cleaning solution could cause damage. Use the following procedure:

### • Caution •

Solvent cleaners and alcohol should not be used on leather upholstery.

1. Clean leather upholstery with a soft bristle brush, and vacuum where necessary.
2. Wipe leather upholstery with a soft, damp cloth.
3. Soiled upholstery, may be cleaned with the approved products available from Cirrus Design. Avoid soaking or harsh rubbing.

## Carpets

To clean carpets, first remove loose dirt with a whiskbroom or vacuum. For soiled spots and stubborn stains use a non-flammable, dry cleaning fluid. Floor carpets may be cleaned like any household carpet.

<b>Cleaning Product</b>	<b>Cleaning Application</b>	<b>Supplier</b>
Prist	Interior Windscreen and Windows	Prist Aerospace
Optimax	Display Screens	PhotoDon
Mild Dishwasher Soap (abrasive free)	Cabin Interior	Any Source
Leather Care Kit 50689-001	Leather Upholstery	Cirrus Design
Leather Cleaner 50684-001	Leather Upholstery	Cirrus Design
Ink Remover 50685-001	Leather Upholstery	Cirrus Design
Leather Conditioner 50686-001	Leather Upholstery	Cirrus Design
Spot and Stain Remover 50687-001	Leather Upholstery	Cirrus Design
Vinyl Finish Cleaner 50688-001	Vinyl Panels	Cirrus Design
Vinyl & Leather Cleaner 51479-001	Vinyl and Leather Upholstery	Cirrus Design

**Figure 8-3**  
**Recommended Interior Cleaning Products**

Intentionally Left Blank

# Section 9

## Supplements

This section of the handbook contains FAA Approved Supplements necessary to safely and to efficiently operate the SR22 when equipped with optional systems or equipment not provided with the standard airplane or for special operations or not included in the handbook. Basically, supplements are mini-handbooks and will contain data corresponding to most sections of the handbook. Data in a supplement adds to, supersedes, or replaces similar data in the basic handbook.

A *Log of Supplements* page immediately follows this page and precedes all Cirrus Design Supplements produced for this airplane. The *Log of Supplements* page can be utilized as a “Table of Contents” for this section. In the event the airplane is modified at a non Cirrus Design facility through an STC or other approval method, it is the owners responsibility to assure that the proper supplement, if applicable, is installed in the handbook and the supplement is properly recorded on the *Log of Supplements* page.

Intentionally Left Blank

# *Section 9*

## *Log of Supplements*

Part Number	Title	Date
___ 13772-101 R1	Garmin GMA 340 Audio System	07-03-04
___ 13772-102	Garmin GTX 327 Transponder	12-12-00
___ 13772-103	Garmin GNS 430 GPS Navigator	12-12-00
___ 13772-104	Garmin GNC 420 GPS Navigator	12-12-00
___ 13772-105	Sandel Avionics SN3308 Navigation Display	01-29-01
___ 13772-107 R1	S-Tec System Thirty Autopilot with GPSS	12-07-04
___ 13772-108 R3	S-Tec System 55X Autopilot w/ Altitude Selector/Alerter	12-07-04
___ 13772-109 R1	Approved Oxygen Systems	10-10-03
___ 13772-110	BF Goodrich WX500 Stormscope Sensor	12-12-00
___ 13772-111	Goodrich SkyWatch SKY497 Traffic Advisory System	08-20-01
___ 13772-112 R2	Avidyne EX5000C Multifunction Flight Display	09-27-04
___ 13772-114	Cirrus Design SR22 Airplanes Registered in Canada	06-05-02
___ 13772-115 R4	Ice Protection System	01-30-05
___ 13772-116 R2	Avidyne Entegra-Series Primary Flight Display	12-07-04
___ 13772-118 R1	Winterization Kit	12-07-04
___ 13772-119	Cirrus Design SR22 Airplanes Registered in Israel	12-03-03
___ 13772-120	Garmin GTX 330 Mode S Transponder	07-03-04
___ 13772-121	Honeywell KGP 560 Terrain Awareness/Warning System	07-03-04

FAA Approved POH Supplements must be in the airplane for flight operations when the subject optional equipment is installed or the special operations are to be performed.

This Log of Supplements shows all Cirrus Design Supplements available for the SR22 at the date shown in the lower left corner. A check mark (✓) in the Part Number column indicates that the corresponding supplement is installed in this POH.

Intentionally Left Blank



**Pilot's Operating Handbook and  
FAA Approved Airplane Flight Manual  
Supplement  
for**

# **Garmin GMA 340 Audio System**

When the Garmin GMA 340 Audio Panel is installed in the Cirrus Design SR22, this Supplement is applicable and must be inserted in the Supplements Section (Section 9) of the Cirrus Design SR22 Pilot's Operating Handbook (Handbook). Information in this supplement either adds to, supersedes, or deletes information in the basic Handbook.

• Note •

This POH Supplement Revision dated 07-03-04 supersedes and replaces the original issue of this supplement dated 12-12-00.

FAA Approved Joseph C. Miss Date July 03 2004  
for Royace H. Prather, Manager  
Chicago Aircraft Certification Office, ACE-115C  
Federal Aviation Administration

## Section 1 - General

This supplement provides detailed operating instructions for the Garmin GMA 340 Audio Selector Panel/Intercom System with internal Marker Beacon. This supplement covers the basic operating areas of the Audio Control Panel.

- Power On / Fail-safe Operation
- Audio / Transceiver Selection
- Speaker Output
- Public Address (PA) Function
- Personal Music Inputs
- Intercom (ICS)
- Marker Beacon

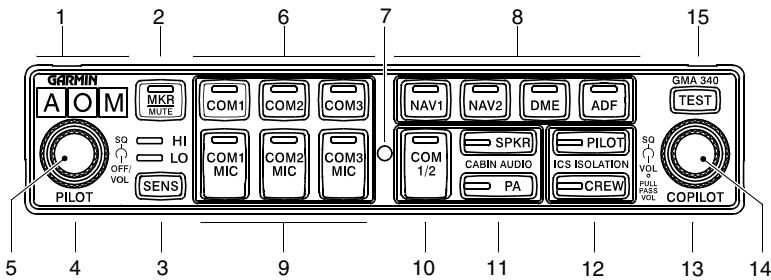

SR22\_FM09\_1108

- |   |   |
|---|---|
| <ol style="list-style-type: none"> <li>1. Marker Beacon Annunciators</li> <li>2. Marker Audio Select Button / LED</li> <li>3. Marker Sensitivity Select Button             <ol style="list-style-type: none"> <li>a. HI Sensitivity LED</li> <li>b. LO Sensitivity LED</li> </ol> </li> <li>4. Pilot Intercom Squelch (outer knob)</li> <li>5. Power / Intercom Volume (inner knob)</li> <li>6. Transceiver Audio Select Buttons/ LEDs</li> <li>7. Photocell</li> <li>8. Receiver Audio Select Buttons / LEDs</li> <li>9. Transceiver Audio/Transmit Select Buttons / LEDs</li> </ol> | <ol style="list-style-type: none"> <li>10. Split COM Button / LED</li> <li>11. Cabin Audio Select Buttons / LEDs             <ol style="list-style-type: none"> <li>a. SPKR, Cabin Speaker</li> <li>b. PA, Public Address</li> </ol> </li> <li>12. Intercom Isolation Buttons / LEDs             <ol style="list-style-type: none"> <li>a. PILOT Intercom Mode</li> <li>b. CREW Intercom Mode</li> </ol> </li> <li>13. Copilot / Passenger Intercom Squelch (outer knob)</li> <li>14. Copilot (IN) / Passenger (OUT) Intercom Volume (inner knob)</li> <li>15. Indicator Test Button</li> </ol> |
|---|---|

**Figure - 1**  
**Audio Control Panel**

## **Section 2 - Limitations**

No change from basic Handbook.

## **Section 3 - Emergency Procedures**

In the event of an audio panel power failure, the audio system will revert to COM 1 for the pilot's mic and headphones and the pilot will have transmit and receive capability.

## **Section 4 - Normal Procedures**

*Refer to Section 7 - System Description* in this supplement for a complete description and operation of the Audio Control Panel.

## **Section 5 - Performance**

No change from basic Handbook.

## **Section 6 - Weight & Balance**

No change from basic Handbook.

## **Section 7 - System Description**

### **Power On and Fail-safe Operation**

The Audio Control Panel is powered 'OFF' when the left inner knob (PILOT) is at the full CCW (counter-clockwise) position. Rotating the knob CW (clockwise) activates the unit. CW rotation of knob beyond the 'on' detent increases pilot ICS (intercom system) volume.

A fail-safe circuit connects the pilot's headset directly to the COM1 transceiver in the event of a power failure to the audio control panel or the panel is switched 'OFF.'

### **Test**

Pressing the TEST button illuminates all Panel LEDs and the Marker Beacon Annunciators full bright. During normal operation, a photocell mounted at the approximate center of the control panel senses ambient light to allow automatic LED and annunciator intensity adjustment. Nomenclature dimming is controlled by the INST lights control on the instrument panel bolster.

## Audio/Transceiver Selection

Audio selection is performed through the eight selector push buttons in the center of the Audio Control Panel. All audio selector push buttons are push-on, push-off. Selecting an audio source supplies audio to the headphones or cabin speaker. Selected audio sources are indicated by illumination of the push-button switch.

Navigation receiver audio source is selected by depressing NAV1, NAV2 (if installed), MKR, DME (if installed), or ADF (if installed) will select that radio or device as the audio source. Audio level of navigation receivers is controlled through the selected radio volume control.

Transceiver audio is selected by depressing COM1, COM2, or COM3 (if installed). When the audio source is selected using the COM1, COM2, and COM3 buttons, the audio source will remain active regardless of which transceiver is selected as the active MIC source.

Both transceiver audio and MIC (microphone) can be selected by depressing COM1 MIC, COM2 MIC, or COM3 MIC (if installed). Both pilot and copilot are connected to the selected transceiver and both have transmit and receive capabilities. Pilot and copilot must use their respective Push-To-Talk (PTT) switch to transmit. The intercom will function normally. During transmissions the active transmitter's COM MIC button LED blinks at a 1 Hz rate indicating active transmission.

### ***Split COM Function***

Pressing the COM 1/2 button activates the split COM function. When split COM is active, COM 1 is the pilot mic/audio source and COM2 is the copilot mic/audio source. The pilot has receive and transmit capabilities on COM1 and the copilot has receive and transmit capabilities on COM2. While split COM is active, simultaneous transmission from COM1 and COM2 is not possible. The pilot and copilot can still listen to COM3, NAV1, NAV2, DME, ADF, and MKR. Pressing the COM 1/2 button a second time will deactivate the split COM function. While split COM is active, the copilot is able to make PA announcements over the cabin speaker allowing the pilot to continue using COM1 independently. This is accomplished by depressing the PA button while split COM is active. Pressing the PA button a second time deactivates this feature and returns the system to normal split COM as described above.

### **COM Swap Mode**

COM swap mode is not available in this installation.

### **Speaker Output**

Pressing the SPKR button will cause the selected airplane radios to be heard over the cabin speaker. Speaker output is muted when a COM microphone is keyed. Speaker level is adjustable through an access hole in the top of the unit (*refer to Garmin installation manual or AMM*).

### **Public Address (PA) Function**

Pressing the PA button on the audio control panel activates the PA function. When PA is activated and either the pilot's or copilot's microphone is keyed (PTT pressed), the corresponding mic audio is output over the cabin speaker. If the SPKR button is also active, any previously active speaker audio will be muted while the microphone is keyed. Pilot and copilot PA microphone speaker levels are adjustable through an access hole in the top of the unit (*refer to Garmin installation manual or AMM*).

### **Personal Music Inputs**

The Audio Control Panel has provisions for up to two separate personal entertainment input (music) devices. These devices are plugged into the AUDIO INPUT jacks in the center console jack panels. MUSIC1 is connected at the AUDIO INPUT jack near the convenience outlet. MUSIC2 is connected to the jack on the aft console. Music1 is soft-muted during all airplane radio activity and normally during intercom (ICS) activity. Music1 and Music2 have characteristics affected by the active ICS isolation mode.

- Pressing the PILOT ICS Isolation button isolates the pilot from the copilot and passengers. Music1 is available to copilot and passengers. Music1 will be muted by copilot or passenger ICS activity.
- Pressing the CREW ICS Isolation button isolates the crew from the passengers and allows the pilot and copilot to listen to Music1 and the passengers to listen to MUSIC2. Radio activity, MKR activity, and pilot or copilot ICS activity will mute Music1. Music 2 is not muted.

- When both the PILOT and CREW ICS Isolation mode are **not** selected, MUSIC1 is available to crew and passengers. Radio activity, MKR activity, and ICS activity will mute Music1.

## Intercom

Intercom controls are located towards the left side of the Audio Control Panel. The controls consist of a Volume control for the pilot and copilot, a Squelch control for all occupants, and an Intercom Mode Selector switch.

### ***Volume & Squelch Control***

ICS volume and voice operated relay (VOX) squelch control is controlled through the left (PILOT) and right (COPILOT) control knobs on the Audio Control Panel Control. Knob control is as follows:

- **Left Inner Knob** – On/Off power control and pilot ICS volume. Full CCW is 'OFF' position (click).
- **Left Outer Knob** – Pilot ICS mic VOX level. CW rotation increases the amount of mic audio (VOX level) required to break squelch. Full CCW is the 'hot mic' position.
- **Right Inner Knob** – When pushed in, rotation controls copilot ICS volume. When out, rotation controls passenger ICS volume.
- **Right Outer Knob** – Copilot and passenger mic VOX level. CW rotation increases the amount of mic audio (VOX level) required to break squelch. Full CCW is the 'hot mic' position.

Each microphone input has a dedicated VOX circuit to assure that only the active microphone(s) is/are heard when squelch is broken. After the operator has stopped talking, the intercom channel remains momentarily open to avoid closure between words or normal pauses.

### ***Control***

The Audio Control Panel provides an adjustable Voice Operated Relay (VOX) Squelch Control for the pilot, copilot, and passengers. Since the VOX circuits reduce the number of microphones active at any one time, the amount of unwanted background noise in the headphones is diminished. This also allows the use of dissimilar headsets with the same intercom. Because the user can adjust the trip level of the VOX squelch to fit the individual voice and microphone, this helps eliminate

the frustration of clipping the first syllables. There is a slight delay after a person stops talking before the channel closes. This prevents closure between words and eliminates choppy communications.

To adjust squelch:

1. With the engine running, set the VOX trip level by slowly rotating the SQL control knob clockwise until you no longer hear the engine noise in the headphones.
2. Position microphone near your lips and speak into microphone. Verify that normal speech levels open the channel.

### ***Intercom Modes***

The GMA 340 provides three intercom (ICS) modes to further simplify workload and minimize distractions during all phases of flight: PILOT, CREW, and ALL. The mode selection is accomplished using the PILOT and CREW push-buttons. Pressing a button activates the corresponding ICS mode and pressing the button a second time deactivates the mode. The operator can switch modes (PILOT to CREW or CREW to PILOT) by pressing the desired modes push-button. ALL mode is active when neither PILOT or CREW have been selected.

- PILOT** The pilot is isolated from the intercom. The pilot can hear radio and sidetone only during radio transmissions. Copilot and passengers can hear the intercom and music but not the airplane radio receptions or pilot transmissions.
- CREW** Pilot and copilot are connected on one intercom channel and have exclusive access to the aircraft radios. They may also listen to MUSIC1. Passengers can continue to communicate with themselves without interrupting the Crew and also may listen to MUSIC2.
- ALL** All parties will hear the aircraft radio, intercom, and MUSIC1. During intercom communications, the music volume automatically decreases. The music volume increases gradually back to the original level after communications have been completed. Both pilot and copilot have access to the COM transceivers.

The following table shows, in abbreviated form, what each occupant hears in each of the selectable Intercom modes:

Mode	Pilot Hears	Copilot Hears	Passenger Hears
PILOT	A/C Radios Pilot	Passengers Copilot Music1	Passengers Copilot Music1
CREW	A/C Radios Pilot/Copilot Music1	A/C Radios Copilot/Pilot Music1	Passengers Music2
ALL	A/C Radio Pilot/Copilot Passengers Music1	A/C Radio Pilot/ Copilot Passengers Music1	A/C Radio Pilot/Copilot Passengers Music1

## Marker Beacon

The Marker Beacon Receiver provides visual and audio indicators to alert the pilot when the airplane passes over a 75 MHz transmitter. Marker beacon controls and lights are located at the extreme left of the Audio Control Panel.

Marker beacon audio is selected by pressing the MKR push-button. If no marker beacon signal is being received, pressing the MKR push-button a second time deselects marker beacon audio. However, if marker beacon is being received, pressing the MKR push-button a second time will mute the audio but the light will continue to flash. Pressing the MKR push-button a third time (while marker beacon audio is muted) deselects marker beacon audio. Marker beacon audio muting automatically disables when the current signal is no longer received.

• Note •

The marker beacon lamps (O, M, A) operate independently of the audio and cannot be disabled.



Marker beacon light and audio keying for ILS approach are summarized below:

- O (Blue)* Outer Marker light and associated 400 Hertz tone. The light and tone are keyed at a rate of two tones/flashes per second.
- M (Amber)* Middle Marker light and associated 1300 Hertz tone. The light and tone are keyed alternately with short and long bursts.
- A (White)* Airway/Inner Marker light and associated 3000 Hertz tone. The light and tone are keyed at a rate of six times per second.

### ***Marker Beacon Sensitivity***

The SENS push-button on the left side of the panel is used to set the marker beacon receiver sensitivity. The selected sensitivity level is indicated by illumination of the HIGH or LOW LED. When HIGH sensitivity is selected, the outer marker beacon tone will sound farther out. Selecting LOW sensitivity at this point allows more accurate location of the Outer Marker. Typically, HIGH sensitivity is selected until the outer marker tone is heard, and then LOW sensitivity is selected for more accurate outer marker location.

Intentionally Left Blank

**Pilot's Operating Handbook and  
FAA Approved Airplane Flight Manual  
Supplement  
for**

# **Garmin GTX 327 Transponder**

When a Garmin GTX 327 Transponder is installed in the Cirrus Design SR22, this Supplement is applicable and must be inserted in the Supplements Section (Section 9) of the Cirrus Design SR22 Pilot's Operating Handbook. This document must be carried in the airplane at all times. Information in this supplement adds to, supersedes, or deletes information in the basic SR22 Pilot's Operating Handbook.

FAA Approved Joseph C. Miess Date DEC 12 2000  
Royace H. Prather, Manager  
Chicago Aircraft Certification Office, ACE-115C  
Federal Aviation Administration

## Section 1 - General

The airplane is equipped with a single Garmin GTX 327 ATC Mode A/C (identification and altitude) transponder with squawk capability. This supplement provides complete operating instructions for the GTX 327 and does not require any additional data be carried in the airplane.

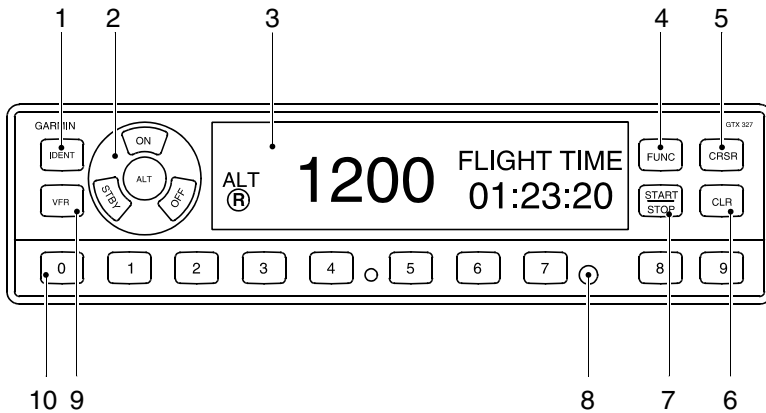

1. Identification Key
2. Mode Selector Keys
  - a. OFF
  - b. STBY (Standby)
  - c. ON
  - d. ALT
3. Display Window
4. FUNC (Function) Key
5. CRSR (Cursor)
6. CLR (Clear) Key
7. START/STOP Key
8. Photocell
9. VFR Key
10. Selector Keys
  - a. 0-7 - Code Selection
  - b. 8-9 - Display Brightness/Contrast

SR22\_FM09\_1501

## Section 2 - Limitations

No Change

## Section 3 - Emergency Procedures

No Change

## Section 4 - Normal Procedures

• Note •

Expected coverage from the GTX 327 is limited to “line of sight.” Low altitude or aircraft antenna shielding by the airplane itself may result in reduced range. Range can be improved by climbing to a higher altitude.

### After Engine Start

1. Avionics Power Switch .....ON  
The transponder will turn on in the STBY mode. The transponder is “on” but will not respond to interrogations from ATC secondary surveillance radar.

### Before Takeoff

1. Transponder Mode Selector Keys .....ALT  
If the transponder is in the STBY mode, it will automatically switch to ALT during takeoff when the groundspeed increases through approximately 35 knots. The transponder will respond to ATC Mode C (altitude and identification) interrogations.

• Note •

Selecting ON puts the transponder in Mode A (identification) only. The transponder will respond to Mode C (altitude) interrogations with signals that contain no altitude information.

### After Landing

1. Transponder Mode Selector Keys ..... STBY or OFF  
If the transponder is in the ALT mode for landing, it will automatically switch to STBY during landing rollout when the groundspeed decreases through approximately 35 knots.

## Section 5 - Performance

No Change

## Section 6 - Weight & Balance

No Change

## Section 7 - Systems Description

• Note •

This supplement provides specific procedures for use of the GTX 327 Transponder in the SR22 and a general description of the unit. For a detailed description of the GTX 327, *refer to GARMIN GTX 327 Mode A/C Transponder Pilots Guide, p/n 190-00187-00 Revision A (Feb 2000) or later revision.*

The Garmin GTX 327 transponder system consists of the integrated receiver/transmitter control unit, an antenna, and an altitude digitizer. The receiver/transmitter receives interrogations from a ground-based secondary surveillance radar transmitter and then transmits to the interrogating Air Traffic Control Center. Digitized altitude information is provided by the altitude digitizer (encoder) plumbed into the airplane static system. The transponder and integrated controls are mounted in the center console. The transponder control provides active code display, code selection, IDENT button, and test functions. The display is daylight readable and is automatically dimmed through a photocell. The controller buttons are dimmed through the INST lights control on the instrument panel bolster. The transponder antenna is mounted on the underside of the fuselage just aft of the firewall. 28 VDC for transponder operation is controlled through the Avionics Master Switch on the bolster switch panel. 28 VDC for receiver, transmitter, and altitude encoder operation is supplied through the 2-amp ENCODER/XPONDER circuit breaker on the Avionics Non-Essential.

## Mode Selector Keys

The mode selector keys are located in a circular arrangement immediately to the left of the display window. The selected mode is annunciated at the left side of the display immediately adjacent to the selector keys. The five positions are:

**OFF** - Turns off all power to the GTX 327 transponder. The transponder should be off until the engine is started. Normally, the transponder can be left in the STBY position and allow the Avionics Power Switch to control system power.

**STBY** - Powers the transponder in standby mode. The last active identification code will be selected. In STBY, the transponder will not reply to any interrogations from an ATC secondary ground surveillance radar system. This is the normal position for ground operations in the SR22.

• Note •

STBY mode is automatically entered from ALT mode during landing ground roll as the groundspeed decreases through 35 knots.

**ON** - Powers on the GTX 327 in Mode A (identification mode.). The last active identification code will be selected. In addition to the airplane's identification code, the transponder will also reply to altitude (Mode C) interrogations with signals that do not contain altitude information.

**ALT** - Places the transponder in Mode A and Mode C, identification and altitude respectively. The transponder will respond to interrogations with the airplane's identification code and standard pressure altitude (29.92 inches Hg).

• Note •

ALT mode is automatically entered from STBY mode during takeoff ground roll as the groundspeed increases through 35 knots.

## Code Selector Keys

Code selection is accomplished by depressing the eight selector keys (numbered 0 - 7) located immediately below the display. Any of 4096 active identification codes can be selected. The selected code must be in accordance with instructions for IFR flight or rules applicable to transponder utilization for VFR flight.

The airplane's transponder code is used to enhance tracking capability by ATC. Therefore, do not switch the transponder to STBY when making routine code changes.

### *Input a New Code*

1. Use CLR key to remove the current code.
2. Use "0 - 7" keys to input the new code. The new code will not be activated until the last (fourth) digit is entered. Pressing the CLR key will move the cursor back to the previous digit. Pressing the CRSR key during code entry will remove the cursor and cancel the entry.

• Note •

When making routine code changes, avoid inadvertent selection of code 7500 and all codes within the 7600 series (7600 – 7677) and 7700 series (7700 – 7777). These codes trigger special indicators in automated facilities. 7500 will be decoded as the hijack code.

### *Important Codes*

- 1200 – VFR code for any altitude in U.S.
- 7000 – VFR code commonly used in Europe
- 7500 – Hijacking
- 7600 – Loss of communications
- 7700 – Emergency
- 7777 – Military interceptor operations (Never squawk this code)
- 0000 – Military use only (not enterable)



## Reply Light

The reply light is the small reverse video “R” immediately below the mode annunciation in the display window. The reply light will blink each time the transponder replies to ground interrogations. The light will remain on during the 18-second IDENT time interval.

## IDENT Key

Pressing the IDENT button activates the Special Position Identification (SPI) pulse for approximately 18 seconds allowing ATC to identify your transponder return from other returns on the controller's scope. The Reply annunciator in the display will illuminate during the SPI pulse. Momentarily press the IDENT key when the controller requests, “SQUAWK IDENT.”

## VFR Key

Pressing the VFR key sets the transponder to the pre-programmed VFR code selected in the configuration mode (factory set to 1200). Pressing the VFR key a second time will restore the previous identification code.

## FUNC Key

Pressing the FUNC key changes the data shown on the right side of the display. Pressing the FUNC key a second time will cycle the display to the next data. Displayed data includes Pressure Altitude, Flight Time, Count Up Timer, Count Down Timer, Contrast, and Display Brightness.

**PRESSURE ALT** - Displays pressure altitude in feet. An arrow to the right of the altitude indicates that the airplane is climbing or descending.

**FLIGHT TIME** - Displays the flight time. The timer receives groundspeed from GPS1. Flight time starts when the groundspeed reaches 35 knots on takeoff and pauses when the groundspeed descends below 35 knots on landing.

**COUNT UP TIMER** - The count up timer is controlled by the START / STOP key. Pressing the CLR key zeros the display.

**COUNT DOWN TIMER** - The count down timer is controlled by the START / STOP key. The CRSR and “0 - 9” keys are used to set the initial time. Pressing the CLR key resets the timer to the initial value.

**CONTRAST** - Allows adjustment of display contrast. When CONTRAST is selected, pressing the “8” key reduces contrast and pressing “9” increases contrast.

**DISPLAY** - The display function is not available in this installation. Display brightness is automatically controlled through a photocell in the front panel.

**Pilot's Operating Handbook and  
FAA Approved Airplane Flight Manual  
Supplement  
For**

# **Garmin GNC 420 GPS Navigator**

When a GARMIN GNC 420 GPS Navigator with VHF COM is installed in the Cirrus Design SR22, this Supplement is applicable and must be inserted in the Supplements Section (Section 9) of the Cirrus Design SR22 Pilot's Operating Handbook. This document must be carried in the airplane at all times. Information in this supplement either adds to, supersedes, or deletes information in the basic SR22 Pilot's Operating Handbook.

FAA Approved Joseph C. Prather Date DEC 12 2000  
Royace H. Prather, Manager  
Chicago Aircraft Certification Office, ACE-115C  
Federal Aviation Administration

## Section 1 - General

The airplane is equipped with a GARMIN GNC 420 GPS Navigator with VHF Com herein referred to as the “Navigator.” The GNC 420 is capable of providing IFR enroute, terminal, and approach navigation with position accuracies better than 15 meters. The system utilizes the Global Positioning System (GPS) satellite network to derive the airplane’s position (latitude, longitude, and altitude) and the altitude digitizer to enhance the altitude calculation.

Provided the GPS Navigator is receiving adequate usable signals, it has been demonstrated capable of and has been shown to meet the accuracy specifications of:

VFR/IFR, enroute, terminal, and instrument approach (GPS) operations, that is, enroute, terminal, and instrument approach within the U.S. National Airspace System, North Atlantic Minimum Navigation Performance Specification (MNPS) Airspace using the WGS-84 (or NAD 83) coordinate reference datum in accordance with the criteria of AC 20-138, AC 91-49, and AC 120-33. Navigation data is based upon use of only the global positioning system (GPS) operated by the United States.

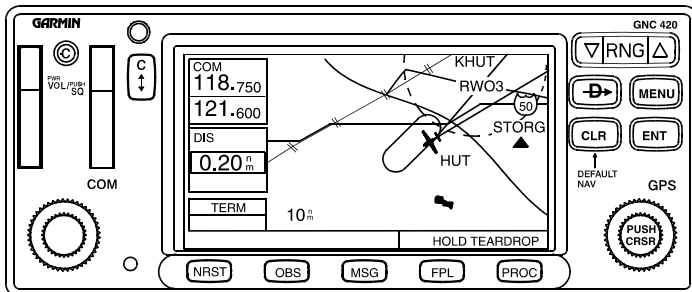

SR22\_FM09\_1285

Figure - 1  
GARMIN GNC 420 Front Panel

## Section 2 - Limitations

1. The GARMIN GNC 420 Pilot's Guide and Reference, P/N 190-00140-20, Revision B dated August 2002 (or later appropriate revision) must be immediately available to the flight crew whenever navigation is predicated on the use of the GPS Navigator. The software status stated in the pilot's guide must match that displayed on the equipment.
2. The Navigator must utilize software version 2.XX (where XX is a digit 0-9).
3. IFR enroute and terminal navigation is prohibited unless the pilot verifies the currency of the database or verifies each selected waypoint for accuracy by reference to current approved data.
4. GPS instrument approaches must be accomplished in accordance with approved instrument approach procedures that are retrieved from the Navigator's NavData database. The database must incorporate the current update cycle.
  - a. Instrument approaches must be conducted in the approach mode and RAIM must be available at the Final Approach Fix.
  - b. Accomplishment of ILS, LOC, LOC-BC, LDA, SDF, and MLS approaches are not authorized in GPS mode.
  - c. When an alternate airport is required by the applicable operating rules, it must be served by an approach based on other than GPS navigation, the aircraft must have operational equipment capable of using that navigation aid, and the required navigation aid must be operational.
5. The aircraft must have other approved navigation equipment installed and operating appropriate to the route or flight.

## Section 3 - Emergency Procedures

1. If GPS Navigator information is not available or is invalid, utilize remaining operational navigation equipment as required.
2. If “RAIM NOT AVAILABLE...” or “RAIM POSITION WARNING” message is displayed, continue to navigate using the GPS equipment or revert to an alternate means of navigation appropriate to the route and phase of flight. When continuing to use GPS navigation, position must be verified every 15 minutes using another IFR approved navigation system.

## Section 4 - Normal Procedures

Normal operating procedures are outlined in the GARMIN GNC 420 Pilot's Guide and Reference, P/N 190-00140-20, Revision B dated August 2002 (or later appropriate revision).

### Activate GPS

1. Battery Master Switch ..... ON
2. Avionics Power Switch ..... ON
3. Navigator Com/ Power Switch..... Rotate ‘ON’

The Navigator will display a welcome page while the self-test is in progress. When the self test is successfully completed, the Navigator asks for NavData database confirmation, acquires position, and then displays the acquired position on the Navigator's display.

• Note •

The Navigator is not coupled to an air and fuel data computer. Manual fuel-on-board and fuel flow entries must be made in order to use the fuel planning function of the AUX pages.

The GPS Navigator utilizes altitude information from the altitude encoder's altitude digitizer to enhance altitude information.

## GPS Course Remote Display

GNC 420 GPS course information is displayed on the airplane CDI.

• Note •

Since the GNC 420 does not provide ILS outputs, the CDI utilized in this installation does not provide glideslope display.

## Deactivate GPS

1. Navigator Com/ Power Switch ..... Rotate CCW 'OFF'

## Section 5 - Performance

No change from basic Handbook.

## Section 6 - Weight & Balance

No change from basic Handbook.

## Section 7 - Systems Description

• Note •

This supplement provides a general description of the GARMIN GNC 420, its operation, and SR22 interface. For a detailed description of the GNC 420 and full operation instructions *refer to the GARMIN GNC 420 Pilot's Guide and Reference*, P/N 190-00140-20, Revision B dated August 2002 (or later appropriate revision).

## GNC 420 Integrated GPS/COM System

This airplane is equipped with a GNC 420 integrated GPS navigator and COM transceiver. The GPS navigator consists of a GPS receiver, a navigation computer, and a Jeppeson NavData database all contained in the GNC 420 control unit mounted in the center console. The GPS is designated 'GPS 2.' Additionally, a VHF communications receiver, designated COM 2, is also integrated into the unit. All tuning and display controls for the GPS and COM are located in the GNC 420 control/display in the center console. The following paragraphs describe the GPS and COM functions of this unit. For a complete description, as well as full operating instructions, *refer to the GARMIN GNC 420 Pilot's Guide and Reference*.

## GPS Navigator

The GARMIN GNC 420 GPS navigator is the secondary system (GPS 2), is IFR certified, and is coupled to the airplane's CDI. The GARMIN GNC 420 GPS navigator is capable of providing IFR enroute, terminal, and approach navigation with position accuracies better than 15 meters. The system utilizes the Global Positioning System (GPS) satellite network to derive the airplane's position (latitude, longitude, and altitude) and the altitude digitizer to enhance the altitude calculation. The GPS 2 antenna is located under the glareshield along the airplane centerline. All GPS navigator controls and functions are accessible through the GNC 420 front control panel located in the center console. The panel includes function keys, power switches, MSG and Nav status annunciators, color LCD display, two concentric selector knobs on each panel, and a Jeppesen NavData card slot in each panel. The GNC 420 navigator is powered by 28 VDC through the 5-amp GPS2 and 7.5-amp COM 2 circuit breakers on the Avionics Non-Essential Bus.

The Jeppesen Navigation Database provides access to data on Airports, Approaches, Standard Instrument Departures (SIDs), Standard Terminal Arrivals (STARs), VORs, NDBs, Intersections, Minimum Safe Altitudes, Controlled Airspace Advisories and Frequencies. North American and International databases are available. Database information is provided on a card that can be inserted into the card slot on the GPS unit. Subscription information is provided in a subscription packet provided with each system.

## Communication (COM) Transceiver

The GNC 420 includes a digitally-tuned integrated VHF communications (COM) transceiver. The transceiver and integrated controls are mounted in the GARMIN GNC 420 unit. The transceiver receives all narrow- and wide-band VHF communication transmissions transmitted within a frequency range of 118.000 MHz to 136.975 MHz in 25.0 kHz steps (720 channels). For European operations, the COM can be operator configured for 8.33 kHz channel spacing (2280 channels). The tuning controls are located at the left side of the GNC 420 front panel. Frequency tuning is accomplished by rotating the large and small concentric knobs to select a standby frequency and then transferring the frequency to the active window. The COM



frequency display window is at the upper left corner of the GNC 420 display. Auto-tuning can be accomplished by entering a frequency from a menu. The COM 2 antenna is located below the cabin on the airplane centerline. 28 VDC for transceiver operating is controlled through the Avionics Master Switch and supplied through the 7.5-amp COM2 circuit breaker on the Avionics Non-Essential Bus.

Intentionally Left Blank

**Pilot's Operating Handbook and  
FAA Approved Airplane Flight Manual  
Supplement  
For**

# **Garmin GNS 430 GPS Navigator**

When a Garmin GNS 430 GPS Navigator with NAV, ILS, and COM is installed in the Cirrus Design SR22, this Supplement is applicable and must be inserted in the Supplements Section (Section 9) of the Cirrus Design SR22 Pilot's Operating Handbook. This document must be carried in the airplane at all times. Information in this supplement either adds to, supersedes, or deletes information in the basic SR22 Pilot's Operating Handbook.

FAA Approved

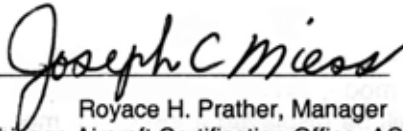

Date DEC 12 2000

Royace H. Prather, Manager  
Chicago Aircraft Certification Office, ACE-115C  
Federal Aviation Administration

## Section 1 - General

The airplane is equipped with a Garmin GNS 430 GPS Navigator with VHF Nav, ILS, and VHF Com herein referred to as the "Navigator." The GNS 430 is capable of providing IFR enroute, terminal, and approach navigation with position accuracies better than 15 meters. The system utilizes the Global Positioning System (GPS) satellite network to derive the airplane's position (latitude, longitude, and altitude) and the altitude digitizer to enhance the altitude calculation.

The GARMIN GNS 430 GPS Navigator may be installed in single or dual installations. If one GNS 430 is installed, it will be designated GPS 1, and a GARMIN GNC 420 GPS Navigator will be installed as GPS 2. Refer to applicable supplements for descriptions of these units.

If two GARMIN GNS 430 Navigators are installed, the upper unit will be designated GPS 1 and the lower unit will be designated GPS 2. In these installations, the MFD and the HSI will display GPS 1 information and the CDI (VOR/LOC/ILS/GS Indicator) will display GPS 2 information.

• Note •

*Refer to GPS 430 INTEGRATION in the NORMAL PROCEDURES Section of this supplement for a more detailed description of GPS 430 integration in the various configurations.*

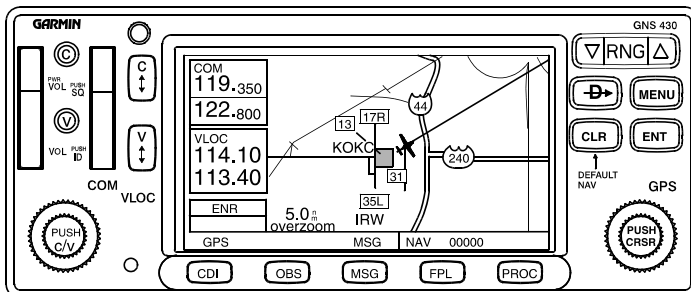

SR22\_FM09\_1109

**Figure - 1**  
**Garmin GNS 430 Front Panel**

## Section 2 – Limitations

Provided the GPS Navigator is receiving adequate usable signals, it has been demonstrated capable of and has been shown to meet the accuracy specifications of:

1. VFR/IFR, enroute, terminal, and instrument approach (GPS, VOR) operations, that is, enroute, terminal, and instrument approach within the U.S. National Airspace System, North Atlantic Minimum Navigation Performance Specification (MNPS) Airspace using the WGS-84 (or NAD 83) coordinate reference datum in accordance with the criteria of AC 20-138, AC 91-49, and AC 120-33. Navigation data is based upon use of only the global positioning system (GPS) operated by the United States.
2. The Garmin GNS 430 Pilot's Guide and Reference, P/N 190-00140-00, Revision F dated July 2000 (or later appropriate revision) must be immediately available to the flight crew whenever navigation is predicated on the use of the GPS Navigator. The software status stated in the pilot's guide must match that displayed on the equipment.
3. The Navigator must utilize software version 2.XX (where X is a digit, 0-9).
4. IFR enroute and terminal navigation is prohibited unless the pilot verifies the currency of the database or verifies each selected waypoint for accuracy by reference to current approved data.
5. GPS instrument approaches must be accomplished in accordance with approved instrument approach procedures that are retrieved from the Navigator's NavData database. The database must incorporate the current update cycle.
  - a. Instrument approaches must be conducted in the approach mode and RAIM must be available at the Final Approach Fix.
  - b. Accomplishment of ILS, LOC, LOC-BC, LDA, SDF, and MLS approaches are not authorized in GPS mode.
  - c. When an alternate airport is required by the applicable operating rules, it must be served by an approach based on other than GPS navigation, the aircraft must have operational equipment capable of using that navigation aid, and the required navigation aid must be operational.

6. The aircraft must have other approved navigation equipment installed and operating appropriate to the route of flight.

## Section 3 - Emergency Procedures

1. If GPS Navigator information is not available or is invalid, utilize remaining operational navigation equipment as required.
2. If “RAIM NOT AVAILABLE...” or “RAIM POSITION WARNING” message is displayed, continue to navigate using the GPS equipment or revert to an alternate means of navigation appropriate to the route and phase of flight. When continuing to use GPS navigation, position must be verified every 15 minutes using another IFR approved navigation system.

## Section 4 - Normal Procedures

The GARMIN GNS 430 Navigator is available in single or dual installations. Operating procedures for each unit of a dual installation are identical. *Refer to the GNS 430 Integration paragraphs* in this supplement for integration differences when single and dual units are installed. Normal operating procedures are outlined in the GARMIN GNS 430 Pilot's Guide and Reference, P/N 190-00140-00, Revision F dated July 2000 (or later appropriate revision).

### Activate GPS

1. Battery Master Switch ..... ON
2. Avionics Power Switch ..... ON
3. Navigator Com/ Power Switch..... Rotate 'ON'

The Navigator will display a welcome page while the self-test is in progress. When the self test is successfully completed, the Navigator asks for NavData database confirmation, acquires position, and then displays the acquired position on the Navigator's display and on the MFD.

• Note •

The Navigator is not coupled to an air and fuel data computer. Manual fuel-on-board and fuel flow entries must be made in order to use the fuel planning function of the AUX pages.

The GPS Navigator utilizes altitude information from the altitude encoder's altitude digitizer to enhance altitude information.

## GNS 430 Integration

The GNS 430 Navigator is integrated into the SR22 Avionics installation in three configurations:

1. Single GARMIN GNS 430 (GPS 1) interfaced with the CDI and MFD and a single GARMIN GNC 250XL (GPS 2) not integrated with a remote indicator.
  - a. In this configuration, pressing the alternate-action CDI push-button on the GARMIN GNS 430 (GPS 1) alternately selects GPS or NAV for display on the CDI each time the button is pressed. The CDI source is indicated by illumination of the "GPS" or "VLOC" annunciation in the lower left corner of the GNS 430 display.

• Note •

The CDI displays course deviation from a VOR, Localizer (LOC) or Glideslope (G/S) when VLOC is selected for display and displays GPS track deviation when GPS is the selected navigation source.

- b. GPS 2 in this configuration is a GARMIN GNC 250XL GPS Navigator with VHF Com. This unit displays GPS data on the unit's display panel only and is not integrated with any remote indicator. *Refer to the SR22 POH Supplement for GARMIN GNC 250XL GPS Navigator, P/N 13772-S05.*
2. Single GARMIN GNS 430 (GPS 1) interfaced with the HSI and MFD and a single GARMIN GNC 420 (GPS 2) interfaced with the CDI (VOR/LOC) indicator.
  - a. In this configuration, pressing the alternate-action CDI push-button on the GARMIN GNS 430 (GPS 1) alternately selects GPS or NAV for display on the HSI and MFD each time the button is pressed. The HSI source is indicated by illumination of the "GPS" or "VLOC" annunciation in the lower left corner of the GNS 430 display.

• Note •

The HSI displays course deviation from a VOR, Localizer (LOC), or Glideslope (G/S) when VLOC is the navigation source and displays GPS track deviation when GPS is the selected navigation source.

- b. GPS 2 in this configuration is a GARMIN GNC 420 GPS Navigator interfaced with the CDI (VOR/LOC Indicator). This unit displays GPS data on the unit's display panel and on the remote CDI (VOR/LOC Indicator). *Refer to the SR22 POH Supplement* for GARMIN GNC 420 GPS Navigator, P/N 13772-S23.
3. Dual GARMIN GNS 430 units are installed. GPS 1 in this configuration is the uppermost GNS 430 unit in the console and GPS 2 is the lower GNS 430 unit.
    - a. GPS 1 in this configuration is a GARMIN GNS 430 GPS Navigator with VHF Com interfaced with the HSI and MFD. Pressing the alternate-action CDI push-button on GPS 1 alternately selects GPS or NAV for display in the HSI and MFD each time the button is depressed. The HSI source is indicated by illumination of the "GPS" or "VLOC" annunciation in the lower left corner of the GNS 430 display.

• Note •

The HSI displays course deviation from a VOR, Localizer (LOC) or Glideslope (G/S) when VLOC is the navigation source and displays GPS track deviation when GPS is the selected navigation source.

- b. GPS 2 in this configuration is a GARMIN GNS 430 GPS Navigator with VHF Com interfaced with the CDI (VOR/LOC/ILS/GS Indicator). Pressing the alternate-action CDI push-button on GPS 2 alternately selects GPS or NAV for display in the CDI each time the button is depressed. The HSI source is indicated by illumination of the "GPS" or "VLOC" annunciation in the lower left corner of the GNS 430 display.

• Note •

The CDI displays course deviation from a VOR, Localizer (LOC) or Glideslope (G/S) when VLOC is the navigation



source and displays GPS track deviation when GPS is the selected navigation source.

## Deactivate GPS

1. Navigator Com/ Power Switch ..... Rotate CCW 'OFF'

## Section 5 - Performance

No change from basic Handbook.

## Section 6 - Weight & Balance

No change from basic Handbook.

## Section 7 - Systems Description

### • Note •

This supplement provides a general description of the Garmin GNS 430, its operation, and SR22 interface. For a detailed description of the GNS 430 and full operation instructions *refer to the Garmin GNS 430 Pilot's Guide and Reference, P/N 190-00140-00, Revision F dated July 2000 (or later appropriate revision).*

The following paragraphs describe a single GARMIN GNS 430 unit and its functions. In the event a second GNS 430 is installed, the second unit will function as described below except that the GPS navigator is designated GPS 2, the NAV receiver is designated NAV 2, and the VHF communications receiver is designated COM 2. The GPS 2 GPS navigator and VHF NAV is powered by 28 VDC through the Avionics Master Switch and the 5-amp GPS2 circuit breaker on the Avionics Non-essential Bus. 28 VDC for transceiver operation is supplied through the Avionics master Switch and the 7.5-amp COM2 circuit breaker on the Avionics Non-Essential Bus.

## GNS 430 Integrated GPS/NAV/COM System

This airplane is equipped with a GNS 430 integrated GPS navigator, NAV receiver, and COM transceiver. The GPS navigator consists of a GPS receiver, a navigation computer, and a Jeppeson NavData database all contained in the GNS 430 control unit mounted in the

center console. The GPS is designated 'GPS 1.' A VHF NAV receiver and tuner for receiving VHF Omni-range (VOR), Localizer (LOC), and Glideslope (G/S) is also integrated into the control unit. The NAV receiver is designated 'NAV 1.' Additionally, a VHF communications receiver, designated 'COM 1,' is also integrated into the unit. All tuning and display controls for the GPS, NAV, and COM are located in the GNS 430 control/display in the center console. The following paragraphs describe the GPS, NAV, and COM functions of this unit. For a complete description, as well as full operating instructions, *refer to the Garmin GNS 430 Pilot's Guide and Reference.*

## GPS Navigator

The Garmin GNS 430 GPS navigator is the primary system (GPS 1), is IFR certified, and is coupled to the airplane's HSI (or HSI) and MFD. Normally, the second GPS Navigator provides backup and is approved for VFR use only. If the second GPS is also a Garmin 430, it will be coupled to the CDI and is also approved for IFR use. The Garmin GPS 430 is capable of providing IFR enroute, terminal, and approach navigation with position accuracies better than 15 meters. The system utilizes the Global Positioning System (GPS) satellite network to derive the airplane's position (latitude, longitude, and altitude) and the altitude digitizer to enhance the altitude calculation. The GPS 1 antenna is located beneath the cabin roof along the airplane centerline and the GPS 2 antenna is located under the glareshield. All GPS navigator controls and functions are accessible through the GNS 430 front control panel located in the center console. The panel includes function keys, power switches, MSG and Nav status annunciators, color LCD display, two concentric selector knobs on each panel, and a Jeppesen NavData card slot in each panel. The GNS 430 navigator is powered by 28 VDC through the 5-amp GPS1 circuit breaker on the Avionics Essential Bus.

The Jeppesen Navigation Database provides access to data on Airports, Approaches, Standard Instrument Departures (SIDs), Standard Terminal Arrivals (STARs), VORs, NDBs, Intersections, Minimum Safe Altitudes, Controlled Airspace Advisories and Frequencies. North American and International databases are available. Database information is provided on a card that can be inserted into the card slot on the GPS unit. Subscription information is provided in a subscription packet provided with each system.

## Navigation (Nav) Receiver

The Garmin GNS 430 provides an integrated Navigation (NAV) receiver with VHF Omrange/Localizer (VOR/LOC) and Glideslope (G/S) capability. The VOR/LOC receiver receives on a frequency range from 108.000 Mhz to 117.950 Mhz with 50 kHz spacing. Glideslope is received from 329.150 to 335.00 in 150 kHz steps. The Nav receiver controls are integrated into the Garmin GNS 430 control mounted in the center console. The receiver control provides active and standby frequency indication, frequency memory storage, and knob-operated frequency selection. IDENT audio output for VOR and LOC is provided to the audio system. The Nav antenna is mounted on top of the vertical tail. 28 VDC for navigation receiver operation is controlled through the Avionics Master Switch on the bolster switch panel and supplied through the 5-amp GPS 1 circuit breaker on the Avionics Essential Bus. The airplane is equipped with a Garmin GNS 430 integrated GPS Navigator, Navigation (NAV) receiver with VHF Omrange/Localizer (VOR/LOC) and Glideslope receiver.

## Communication (COM) Transceiver

The GNS 430 includes a digitally-tuned integrated VHF communications (COM) transceiver. The transceiver and integrated controls are mounted in the Garmin GNS 430 unit. The transceiver receives all narrow- and wide-band VHF communication transmissions transmitted within a frequency range of 118.000 MHz to 136.975 MHz in 25.0 kHz steps (720 channels). For European operations, the COM can be operator configured for 8.33 kHz channel spacing (2280 channels). The tuning controls are collocated with the NAV at the left side of the GNS 430 front panel. Frequency tuning is accomplished by rotating the large and small concentric knobs to select a standby frequency and then transferring the frequency to the active window. The COM frequency display window is at the upper left corner of the GNS 430 display. Auto-tuning can be accomplished by entering a frequency from a menu. The COM 1 antenna is located above the cabin on the airplane centerline. 28 VDC for transceiver operating is controlled through the Avionics Master Switch and supplied through the 7.5-amp COM1 circuit breaker on the Avionics Essential Bus.

Intentionally Left Blank

**Pilot's Operating Handbook and  
FAA Approved Airplane Flight Manual  
Supplement  
for**

# **Sandel Avionics SN3308 Navigation Display**

When a Sandel Avionics SN3308 Navigation Display is installed in the Cirrus Design SR22, this Supplement is applicable and must be inserted in the Supplements Section (Section 9) of the applicable Cirrus Design SR22 Pilot's Operating Handbook. This document must be carried in the airplane at all times. Information in this supplement adds to, supersedes, or deletes information in the basic SR22 Pilot's Operating Handbook.

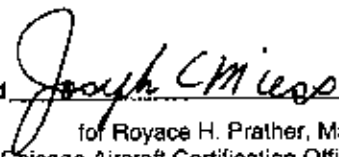
FAA Approved  Date JAN 29 2001  
for Royace H. Prather, Manager  
Chicago Aircraft Certification Office, ACE-115C  
Federal Aviation Administration

## Section 1 - General

The airplane is equipped with a Sandel SN3308 navigation display. This SN3308 is a three-inch instrument installed in the pilot's instrument panel, which performs the functions of a standard HSI combined with a two-pointer RMI. The instrument also displays a moving map, marker beacon, WX500 stormscope data, and GPS data.

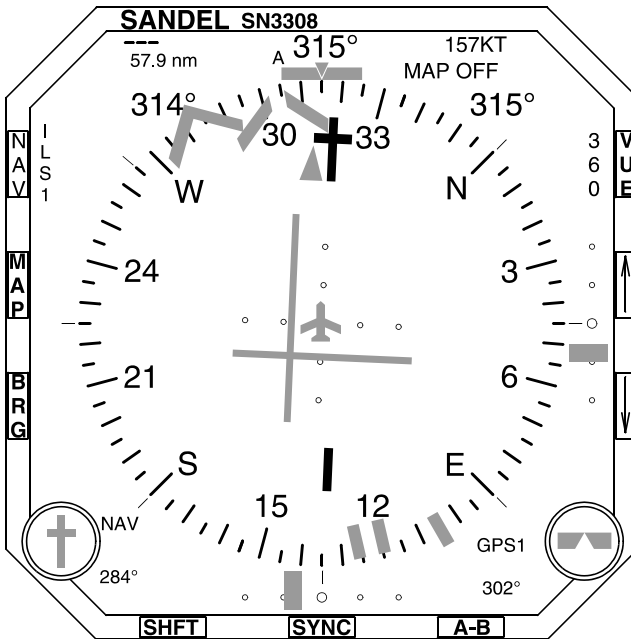

SR22\_FM09\_1504

Figure - 1  
SN3308 Navigation Display

## Section 2 - Limitations

1. The Sandel Avionics SN3308 Navigation Display Pilot's Guide, SPN 90106-PG Revision C or later revision, must be immediately available to the flight crew when navigation is predicated on use of the Sandel SN3308 Navigation Display.
2. The "CRC Self Test Failed" message must not appear on power-up if flight operations are predicated on the use of the SN3308 Navigation Display.
3. If flight into IMC is anticipated, the airplane must be flown from the left seat.

## Section 3 - Emergency Procedures

1. If the SN3308 Navigation Display fails to operate, use the magnetic compass as the heading source.
2. If the remote directional gyro fails or becomes inoperative, the compass rose color will change from white to amber and the flux gate will provide the heading. The heading display will respond much more slowly than normal.
3. If the fluxgate fails, the SN3308 Navigation Display compass rose color will change from white to amber and the heading numbers will disappear. The display can be used to determine relative heading for turns; however, the magnetic compass must be used to determine absolute heading.
4. The SN3308 Navigation Display is powered through redundant 5-amp circuit breakers. HSI #1 circuit breaker is on the Essential Bus and HSI #2 circuit breaker is on Main Bus 2. Either circuit is capable of powering the Navigation Display.
5. *Refer to the Sandel Avionics SN3308 navigation Display Pilot's Guide* for error messages and alerts.

## Section 4 - Normal Procedures

### Activate Navigation Display

1. Battery Master Switch ..... ON
2. Avionics Power Switch ..... ON
3. The Navigation display will be active and capable of displaying data from either VOR-ILS or GPS.
  - a. Selection of the primary navigation source between VOR-ILS 1 and GPS 1 is accomplished by pressing the NAV switch on the left side of the SN3308 Navigation Display to connect the navigation source to the HSI course pointer and the autopilot.
  - b. Selection of the bearing pointer source between VOR 1, VOR 2, GPS 1 or GPS 2 is accomplished by using the BRG switch on the left side of the SN3308 Navigation Display.
  - c. Annunciation of the navigation source and all modes is accomplished by on-screen annunciation.

### Deactivate Navigation Display

1. Avionics Power Switch ..... OFF

## Section 5 – Performance

No change.

## Section 6 - Weight & Balance - No change.

## Section 7 - Systems Description

### Sandel SN3308 Navigation Display

• Note •

For a full description of the Sandel SN3308 Navigation Display, refer to the *Sandel Avionics SN3308 Navigation Display Pilot's Guide*, SPN 90106-PG Revision C or later revision,



This airplane is equipped with a Sandel SN3308 Navigation Display to provide course data from Nav 1 or GPS 1 and bearing data from Nav 1, Nav 2, GPS 1 or GPS 2. The Navigation display also indicates heading, glideslope, marker beacon, and lightning strike information from a WX500 stormscope sensor (if installed). Heading information is provided by a gyro stabilized flux detector. VOR, ILS, and GPS course data is derived from the primary GNS 430 Nav Receiver. Display dimming is accomplished through a dimmer switch immediately below the display. Redundant power sources provide 28 VDC for system operation. Power is supplied through the 5-amp HSI #1 circuit breaker on the Essential Bus and the 5-amp HSI #2 circuit breaker on Main Bus 2. Either circuit is capable of powering the Navigation Display.

Intentionally Left Blank

Pilot's Operating Handbook and  
FAA Approved Airplane Flight Manual  
Supplement  
For

# S-Tec System Thirty Autopilot with GPSS

When the S-Tec System Thirty Autopilot with GPSS is installed in the Cirrus Design SR22, this Supplement is applicable and must be inserted in the Supplements Section (Section 9) of the Cirrus Design SR22 Pilot's Operating Handbook. This document must be carried in the airplane at all times. Information in this supplement adds to, supersedes, or deletes information in the basic SR22 Pilot's Operating Handbook.

• Note •

This POH Supplement Revision dated 12-07-04 supersedes and replaces the Original Issue of this supplement dated 11-02-01.

FAA Approved Joseph C. Miss Date Dec 07 2004  
for Royace H. Prather, Manager  
Chicago Aircraft Certification Office, ACE-115C  
Federal Aviation Administration

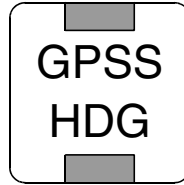
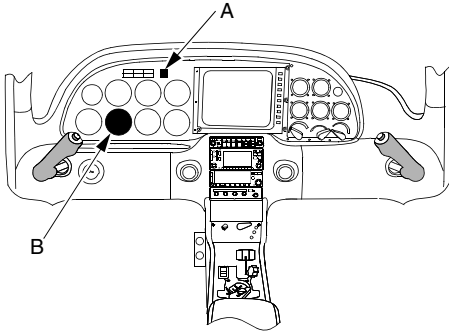

**DETAIL A**

GPSS SWITCH

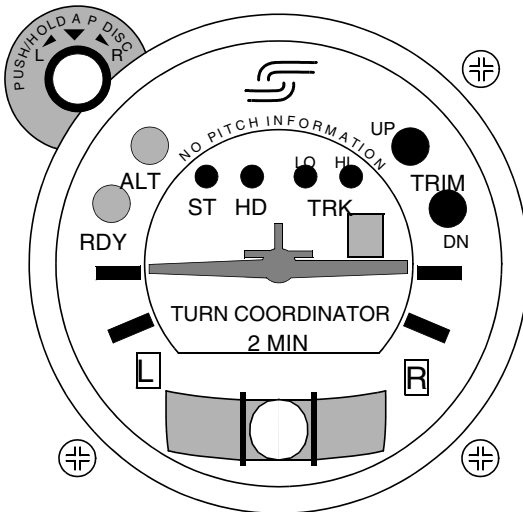

**DETAIL B**

TURN COORDINATOR

SR22\_FM09\_1515

**Figure - 1**  
**System 30 Autopilot**

## Section 1 - General

This airplane is equipped with an S-TEC System Thirty Autopilot. This two-axis autopilot system receives roll axis control inputs from an integral electric turn coordinator and altitude information from an altitude transducer plumbed into the pitot-static system. The programmer, roll computer/amplifier, and annunciators are contained entirely within the turn coordinator case. The Multi-function Control Knob at the upper left of the turn coordinator provides mode selection, disengage, and turn command functions. A separate pitch computer provides the ALT hold function. The S-Tec System Thirty Autopilot features:

- Roll Stabilization.
- Turn Command.
- NAV/LOC/GPS tracking; HI and LO sensitivity.
- Altitude Hold.

A separate GPSS converter provides GPS roll steering to the autopilot. A GPSS/HDG button allows the operator to switch between HDG and Roll Steering modes. In the HDG mode the autopilot responds to the HDG bug on the HSI. In the GPSS mode, the autopilot responds to roll steering inputs from the GPS navigator.

*Refer to S-TEC System Thirty Autopilot Pilot's Operating Handbook (P/N 8777) dated Feb 1999 or later and Section 7 of this supplement for a more complete description of the autopilot, its operating modes, and additional detailed operating procedures.*

*Refer to S-TEC-Meggitt Global Positioning System Steering (GPSS) Converter Pilot's Operating Handbook (P/N 8799) dated 8 Feb 2001 or later and section 7 of this supplement for a more complete description of the GPSS converter, its modes, and additional operating procedures.*

## Section 2 - Limitations

1. Autopilot operation is prohibited above 185 KIAS.
2. The autopilot must not be engaged for takeoff or landing.
3. The autopilot must be disengaged for missed approach, go-around, and balked landing.
4. Flaps must be set to 50% for autopilot operation in Altitude Hold at airspeeds below 95 KIAS.
5. Flap deflection is limited to 50% during autopilot operations.
6. The autopilot must be disconnected in moderate or severe turbulence.
7. The autopilot must be disengaged no later than 100 feet below the Minimum Descent Altitude.
8. Minimum engage height for the autopilot is 400 ft AGL.
9. Minimum speed with the autopilot engaged is  $1.2V_s$  for the given configuration.

## Section 3 - Emergency Procedures

### Autopilot Malfunction

Refer to *Electric Trim/Autopilot Failure* procedure in the basic Handbook. Do not reengage the autopilot until the malfunction has been identified and corrected.

• Note •

A GPSS malfunction will most likely affect the autopilot HD (Heading) mode, rendering it unusable. However, it may be possible to use other autopilot lateral modes such as NAV or approach, or the pitch (ALT) mode. Exercise caution when examining these functions after a malfunction.

The autopilot may be disconnected by:

1. Pressing and holding the Mode Selector Knob on the Turn Coordinator for approximately 2 seconds.
2. Pressing the A/P DISC/Trim switch on either control yoke handle.
3. Pulling the AUTOPILOT circuit breaker on the Essential Bus.

Altitude lost during a roll or pitch axis autopilot malfunction and recovery:

Flight Phase	Bank Angle	Altitude Loss
Climb	40°	200 ft
Cruise	45°	300 ft
Descent	40°	350 ft
Maneuvering	10°	60 ft

## Section 4 - Normal Procedures

Refer to Section 7 – Systems Description for a description of the autopilot and its modes.

### Autopilot Pre-Flight Test

1. Battery Master Switch ..... ON
2. Avionics Power Switch ..... ON

Note that all autopilot annunciators illuminate. After about 10 seconds, all lights will go out. When the turn coordinator gyro has reached operational RPM, the green RDY light will illuminate. The HDG lamp on the GPSS/HDG switch will illuminate and remain illuminated.

3. ST (Stabilizer) Mode ..... TEST
  - a. Momentarily depress Autopilot Mode Selector, and note that ST (Stabilizer) light illuminates.
  - b. Then rotate Mode Selector Knob left then right. Note that control yokes follow movement of knob.
4. Heading Mode ..... TEST
  - a. Center the HDG bug under the lubber line on the HSI.
  - b. Momentarily depress Autopilot Mode Selector. Note that HD (Heading) light illuminates.
  - c. Then rotate HDG knob on the HSI to the left then right. Note that control yokes follow movement of knob. Then return HDG bug to lubber line.
  - d. Activate a GPS flight plan or waypoint on the GPS navigator (GPS 1).
  - e. Press and release the GPSS/HDG switch. HDG will go out and GPSS will flash. Note that the HDG bug will no longer move the control yokes.

• Note •

The GPSS requires a ground speed component to function, therefore the GPSS function cannot be ground tested.



- f. Press and release the GPSS/HDG switch. GPSS will go out and HDG will come on.
5. Altitude Hold ..... TEST
  - a. Depress either pilot's or copilot's A/P ALT HOLD button (control yoke). Note that ALT (Altitude Hold) light illuminates.
  - b. Slowly apply forward pressure on the control yoke. Note that TRIM UP light illuminates. Release pressure. TRIM UP light will go out.
  - c. Slowly pull control yoke aft. Note that TRIM DN light illuminates. Release pressure. TRIM DN light will go out.
6. Overpower Test:
  - a. Grasp control yoke and input left aileron, right aileron, nose up, and nose down to overpower autopilot. Overpower action should be smooth with no noise or jerky feel.
  - b. Depress the A/P ALT HOLD button. Note ALT light goes out.
7. Radio Check:
  - a. Turn on NAV1 radio, with a valid NAV signal, and select VLOC for display on the HSI.
  - b. Use Autopilot Mode Selector to engage TRK LO mode and move OBS so that VOR deviation needle moves left or right. Note that control yokes follow direction of needle movement.
  - c. Use Autopilot Mode Selector to engage TRK HI mode and move OBS so that VOR deviation needle moves left or right. Note that control yokes follow direction of needle movement with more authority than in TRK LO mode.
8. Autopilot Disconnect Tests:
  - a. Depress either pilot's or copilot's A/P ALT HOLD button (control yoke). Note that ALT (Altitude Hold) light illuminates.
  - b. Press and hold Autopilot Mode Selector for approximately 2 seconds. Note that the autopilot disengages. Move control yoke to confirm that pitch and roll control is free with no control restriction or binding.
  - c. Momentarily depress Autopilot Mode Selector. Note that autopilot engages in ST (Stabilizer) mode.

- d. Depress either pilot's or copilot's A/P ALT HOLD button (control yoke). Note that ALT (Altitude Hold) light illuminates.
- e. Press Pilot A/P DISC/Trim Switch (control yoke). Note that the autopilot disengages. Move control yoke to confirm that pitch and roll control is free with no control restriction or binding.
- f. Repeat steps c. through e. using Copilot Trim Switch.

## Inflight Procedures

- 1. RDY Light .....CHECK ON
- 2. Trim airplane for existing flight conditions.
- 3. Center Autopilot Mode Selector Knob and then depress once to enter ST (Stabilizer) mode.
- 4. Rotate Autopilot Mode Selector Knob as desired to setup level or turning flight.

### **Heading Mode**

- 1. Begin by selecting a heading on the HSI within 10° of the current airplane heading.
- 2. Use Autopilot Mode Selector to select HD (Heading) mode. The HD light will come on and the airplane will turn toward the selected heading.
- 3. Use the HSI HDG knob to make heading changes as desired.

### **Altitude Hold Mode**

- 1. Manually fly the airplane to the desired altitude and level off.

• Note •

For smoothest transition to altitude hold, the airplane rate of climb or descent should be less than 100 FPM when Altitude Hold is selected.

- 2. With Autopilot on (ST annunciator on or another roll mode active), press either the pilot's or the copilot's A/P ALT HOLD button (control yoke). The ALT annunciator will illuminate indicating that the mode is engaged and the autopilot will hold the present altitude.

• Note •

Manually flying the airplane off the selected altitude will not disengage altitude hold and the autopilot will command a pitch change to recapture the altitude when the control input is released.

Illumination of either the TRIM UP or the TRIM DN annunciator indicates the airplane is out of trim and must be manually trimmed in the direction indicated.

### ***GPS Tracking and GPS Approach (Without GPSS)***

1. Begin with a reliable GPS signal and HSI course needle centered, with airplane on the suggested heading to the waypoint.

• Note •

The airplane must be within 5° of the desired course when TRK is selected. If airplane is more than 5° off the selected course the autopilot will turn the airplane towards the course but may not capture and track it.

2. Use Autopilot Mode Selector to select TRK HI mode for GPS approach and cross-country tracking.

### ***GPS Tracking and GPS Approach (With GPSS)***

• Note •

GPSS can be used for enroute navigation or GPS approaches.

### **GPS Enroute Navigation**

1. Use Autopilot Mode Selector to select HD mode. The HD light will come on.
2. Select HDG mode with GPSS/HDG switch.
3. Program or activate the desired waypoint or flight plan into the GPS navigator (GPS 1).
4. Select GPSS mode with GPSS/HDG switch. Observe GPSS illuminates steady.
5. Verify that the autopilot immediately begins tracking to the desired waypoint.

• Note •

The autopilot will automatically track to the active waypoint anytime GPS 1 has a valid waypoint programmed and the pilot selects GPSS with the autopilot in the HD (Heading) mode.

When operating in the GPSS mode, the autopilot does not use inputs from the HSI HDG knob or course control; therefore, the pilot is not required to set these in any position. However, the pilot will be required to revert to the HDG mode to maneuver the aircraft for a holding pattern or procedure turn since these elements are not contained in the navigator database.

If GPSS flashes when engaged, either GPS 1 is not or does not have an active waypoint or flight plan, or the bank angle and ground speed signals are not being received or is not valid.

If GPSS begins to flash, the airplane will go wings level in 0.5 to 2.0 seconds. At this time, the pilot can either enter a valid GPS waypoint or press and release the GPSS/HDG switch to return the autopilot to the HD (Heading) mode.

### **GPS Approach Procedures (With GPSS)**

6. Use Autopilot Mode Selector to select HD mode. The HD light will come on.
7. Select HDG mode with GPSS/HDG switch.
8. Select and activate the desired approach on the GPS navigator (GPS 1).
9. Select GPSS mode with GPSS/HDG switch. Observe GPSS illuminates steady.
10. Verify that the autopilot immediately begins tracking to the desired initial approach fix.

• Note •

If the selected approach contains a procedure turn or a holding pattern, the pilot must:

- a. Set the HSI HDG bug to current airplane heading.
- b. When approaching the procedure turn, use the GPSS/HDG switch to select the HDG mode.

- c. Lead the airplane around the procedure turn or holding pattern using the HSI HDG knob.
  - d. When approaching the desired inbound course, once again select GPSS.
  - e. Conduct remainder of the approach in the GPSS mode.
11. Monitor course-tracking quality during GPSS operations.

### ***VOR Tracking and VOR-LOC Approach***

1. Begin with a reliable VOR or VOR-LOC signal and HSI course needle centered, with airplane on the suggested heading to the waypoint.

• Note •

The airplane must be within 5° of the desired course when TRK is selected. If airplane is more than 5° off the selected course, the autopilot will turn the airplane towards the course but may not capture and track it.

2. Use Autopilot Mode Selector to select TRK HI mode for approach or TRK HI or LO for cross-country tracking.

## **Section 5 - Performance**

There is no change to the airplane performance when the S-Tec System Thirty Autopilot is installed.

## **Section 6 - Weight & Balance**

There is no change to the airplane weight & balance when the S-Tec System Thirty Autopilot is installed.

## Section 7 - Systems Description

The airplane is equipped with an S-Tec System Thirty two-axis Automatic Flight Control System (Autopilot). The autopilot roll axis uses an inclined gyro in the turn coordinator case as the primary turn and roll rate sensor. In addition to the turn coordinator instrument and rate gyro, the case encloses an autopilot pick-off, a gyro RPM detector, an instrument power monitor, and the autopilot roll computer/amplifier. An altitude transducer plumbed into the pitot-static system provides altitude information to a separate pitch computer installed within the console. Roll axis steering is accomplished by autopilot steering commands to the aileron trim motor and spring cartridge. Pitch axis command for altitude hold is accomplished by pitch computer commands to the elevator servo. Low electrical power will cause the Turn Coordinator to flag and low RPM will cause the autopilot to disconnect. 28 VDC for autopilot operation is supplied through the 5-amp AUTOPILOT circuit breaker on the Essential Bus. Turn Coordinator instrument dimming is controlled through the INST light dimmer on the bolster switch panel.

The system also incorporates a GPSS (GPS Steering) converter and switch to apply roll steering commands from GPS1 to the autopilot. The GPSS function consists of a GPSS/HDG switch, a GPSS converter box, and associated wiring. During normal flight operations, the system can be switched from heading to GPSS modes of operation. In heading mode, the converter receives a heading error signal from the Horizontal Situation Indicator (HSI). The converter processes the signal and sends the heading error to the autopilot. In the GPSS mode, the converter uses digital groundspeed and bank angle signals from GPS1 that are converted to a commanded turn rate. The turn rate is scaled and converted to a heading error signal for the autopilot. This allows the autopilot to be directly coupled to the GPS1 roll steering output, without the need for the pilot to make adjustments using the HSI course (OBS) control or the HSI heading (HDG) bug.

All Autopilot mode selection and annunciation is performed with the Turn Coordinator Control Knob and the A/P ALT HOLD buttons on the pilot's and copilot's control yokes. *Refer to Figure 1* for an illustration of the following listed modes and controls:

**RDY (Ready) Light** – Illuminates green when autopilot is ready for engagement. When the airplane's Batt Master switch is turned on and the rate gyro RPM is correct, the green RDY light comes on indicating the autopilot is ready for the functional check and operation. The autopilot cannot be engaged unless the RDY light is on.

**Mode Select / Disconnect Switch** – Each momentary push of the knob will select an autopilot mode, left to right, beginning with ST (Stabilizer) mode and ending with TRK HI (Track) mode. Holding the knob in for more than 2 seconds will disengage the autopilot. Depressing either control yoke trim switch will also disengage the autopilot.

**ST (Stabilizer) Mode** - Turning the Mode Select Knob left or right in ST (Stabilizer) mode will provide left/right steering commands to the autopilot proportional to the knob displacement. Steering command is limited to a standard rate turn maximum.

**HD (Heading) Mode** – When HD is selected, the autopilot responds to heading changes made using the HDG knob on the HSI if the GPSS/HDG switch is in the HDG mode. When HDG mode is selected, the autopilot will turn the airplane to the selected heading and then follow the selected heading. Subsequent heading changes can be made using the HDG knob on the HSI. For smoothest transition to HDG, it is recommended that the airplane be aligned to within 10° of the selected heading before engaging HDG.

**TRK (Track) Mode** – When TRK LO is selected, the autopilot will provide low system gain for comfortable cross-country tracking of GPS or VOR courses. When TRK HI is selected, the autopilot will provide a higher level of system gain for more active tracking of GPS, VOR, or Localizer front course signals.

**ALT (Altitude Hold), Mode** – When ALT is selected by pressing either A/P ALT HOLD button on the control yoke handles, the autopilot will hold the altitude at the time the mode was selected. Altitude hold will not engage if an autopilot roll mode is not engaged. Pressing an A/P ALT HOLD button again or disengaging the autopilot using Mode Select/Disconnect switch or control yoke trim switches will disengage altitude hold.

During ALT mode operation, illumination of either the yellow TRIM UP and TRIM DN annunciators indicates that the airplane is out of trim

and the pilot should manually trim the airplane in the direction indicated. If the pilot fails to trim the airplane, the TRIM UP or TRIM DN light, as applicable, will flash. Both light are out if the airplane is in trim.

**Flag Window** – A red flag indicates insufficient electrical power (less than 24 VDC) to the Turn Coordinator rate gyro. The turn coordinator has its own backup power supply. *Refer to basic Handbook.*

GPSS and HDG mode selection for the GPSS converter is accomplished through the GPSS/HDG switch located next to the system annunciators on the instrument panel. *Refer to Figure 1* for an illustration of the switch.

**HDG** – When HDG is selected on the GPSS/HDG switch, the green light below the HDG label will illuminate. In this mode, the autopilot is coupled to the HSI heading error outputs and the autopilot will respond to inputs made on the HSI heading (HDG) or course (OBS) controls.

**GPSS** – When GPSS is selected on the GPSS/HDG switch, the green light above the GPSS label will illuminate. In this mode, the autopilot is coupled to the GPS1 roll steering output and, if the autopilot is in heading (HD) mode and GPS1 has a valid waypoint of flight plan active, the system will automatically track to the next waypoint.



**Pilot's Operating Handbook and  
FAA Approved Airplane Flight Manual  
Supplement  
For**

# **S-Tec System 55X Autopilot w/ Altitude Selector/Alerter**

When the S-Tec System Fifty Five X (55X) Autopilot with Altitude Selector / Alerter is installed in the Cirrus Design SR22, this Supplement is applicable and must be inserted in the Supplements Section (Section 9) of the Cirrus Design SR22 Pilot's Operating Handbook. This document must be carried in the airplane at all times. Information in this supplement adds to, supersedes, or deletes information in the basic SR22 Pilot's Operating Handbook.

• Note •

This POH Supplement Revision dated 12-07-04 supersedes and replaces Revision 2 of this supplement dated 10-10-03.

FAA Approved Joseph C. Mies Date Dec 07 2004  
for Royace H. Prather, Manager  
Chicago Aircraft Certification Office, ACE-115C  
Federal Aviation Administration

## **Section 1 - General**

This airplane is equipped with an S-TEC System 55X Autopilot. The System 55X autopilot is a two-axis autopilot system. The system consists of a flight guidance programmer/computer, altitude encoder, altitude selector / alerter, turn coordinator, and HSI. Mode selection and vertical speed selection is made on the programmer/computer panel. A button on each control yoke handle may be used to disengage the autopilot. The autopilot makes roll changes through the aileron trim motor and spring cartridge and makes pitch changes for altitude hold through the elevator trim motor. The SR22 installation of the S-Tec System 55X Autopilot features:

- Heading Hold and Command;
- NAV/LOC/GPS/GS tracking, high and low sensitivity, and automatic 45° course intercept;
- Altitude Pre-select, Hold and Command, Altitude display, and bar correction;
- Altitude and Decision Height (DH) alert; and
- Vertical Speed Hold and Command.

*Refer to S-Tec System Fifty-Five X Autopilot Pilot's Operating Handbook (POH), P/N 87109 dated 8 November 2000 or later revision for full operational procedures and description of implemented modes. The System 55X POH also contains detailed procedures for accomplishing GPS & VOR course tracking, front course and back course localizer approaches, and glideslope tracking.*

*Refer to S-Tec Altitude Selector / Alerter (P/N 0140) Pilot's Operating Handbook (POH), P/N 8716 (no revision or later) for full operational procedures and detailed description of operational modes of the Altitude Selector / Alerter.*

• Note •

The SR22 implementation of the System 55X Autopilot does not utilize the optional remote annunciator, roll servo, and optional trim servo. Therefore, all references to these items in the S-Tec System 55X POH shall be disregarded. Additionally, this installation does not utilize a CWS (Control Wheel Steering) switch or an AUTOPILOT MASTER switch.

• Note •

This installation utilizes the airplane's roll trim actuator to affect steering changes. Therefore, the automatic trim function of the System 55X is not implemented. Disregard all references in the S-Tec System 55X POH to this feature.

Roll information is displayed on the HSI. Autopilot Flight Director is not implemented in this installation.

## Section 2 - Limitations

1. Autopilot operation is prohibited above 185 KIAS.
2. The autopilot must not be engaged for takeoff or landing.
3. The autopilot must be disengaged for missed approach, go-around, and bailed landing.
4. Flaps must be set to 50% for autopilot operation in Altitude Hold at airspeeds below 95 KIAS.
5. Flap deflection is limited to 50% during autopilot operations.
6. The autopilot must be disconnected in moderate or severe turbulence.
7. Minimum engage height for the autopilot is 400 ft AGL.

• **WARNING** •

Autopilot may not be able to maintain all selectable vertical speeds. Selecting a vertical speed that exceeds the aircraft's available performance may cause the aircraft to stall.

8. Minimum speed with the autopilot engaged is  $1.2V_S$  for the given configuration.
9. For VOR/GPS and ILS glideslope and localizer intercept, capture, and tracking, the following limitations apply:
  - a. The autopilot must be disengaged no later than 100 feet below the Minimum Descent Altitude.
  - b. The autopilot must be disconnect during approach if course deviation exceeds 50%. The approach should only be continued by "hand-flying" the airplane.
  - c. The autopilot must be disengaged at the Decision Height.

- d. 12 knot maximum crosswind component between the missed approach point and outer marker.
  - e. The intercept of the localizer shall occur at least 5 miles outside of the outer marker.
  - f. If the crosswind component is greater than 12 knots and less than 17 knots, the intercept shall occur at least 10 miles outside of the outer marker.
  - g. The intercept angle shall be no greater than a 45-degree intercept.
  - h. The ILS is flown at normal approach speeds, and within any STC or TC speed constraints and as defined in this flight manual.
  - i. The flaps should be extended in the approach configuration prior to the Outer Marker. No further changes in the flap configuration should be made throughout the autopilot-coupled approach.
  - j. The glideslope is approached in such a manner to allow automatic arming of the glideslope, or if the glideslope is manually armed no more than 15% above the glideslope.
10. The S-TEC System Fifty Five X Pilot's Operating Handbook, P/N 87109 dated 8 November 2000 or later, must be carried in the airplane and available to the pilot while in flight.

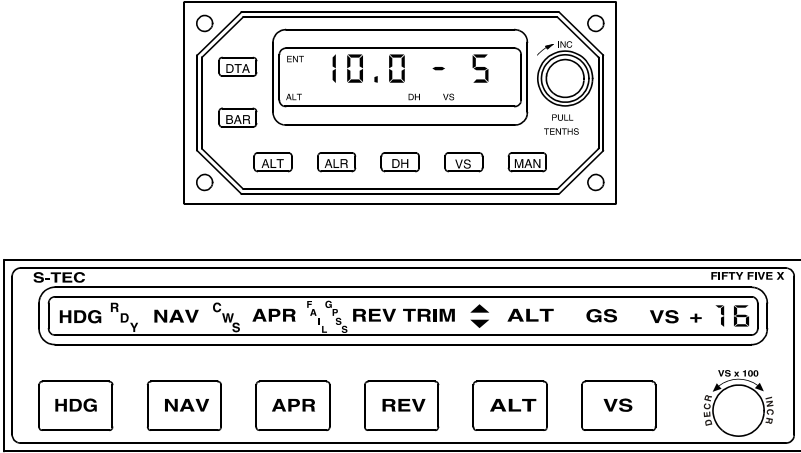

SR22\_FM09\_1502A

**Figure - 1**  
**System 55X Altitude Selector/Alerter & Autopilot Computer**  
P/N 13772-108  
Revision 3: 12-07-04

## Section 3 - Emergency Procedures

### Autopilot Malfunction

Refer to *Electric Trim/Autopilot Failure* procedure in the SR22 POH. Do not reengage the autopilot until the malfunction has been identified and corrected. The autopilot may be disconnected by:

1. Pressing the A/P DISC/Trim switch on the control yoke handle.
2. Pulling the AUTOPILOT circuit breaker on Essential Bus.

Altitude lost during a roll or pitch axis autopilot malfunction and recovery:

Flight Phase	Bank Angle	Altitude Loss
Climb	40°	200 ft
Cruise	45°	300 ft
Descent	40°	350 ft
Maneuvering	10°	60 ft
Approach	10°	80 ft

## System Failure and Caution Annunciations

If any of the following failure annunciations occur at low altitude or during an actual instrument approach, disengage the autopilot, execute a go-around or missed approach as appropriate. Inform ATC of problem. Do not try to troubleshoot until a safe altitude and maneuvering area are reached or a safe landing is completed.

Annunciation	Condition	Action
Flashing RDY for 5 seconds with audible tone.	Autopilot disconnect. All annunciations except RDY are cleared.	None.
Flashing RDY with audible tone then goes out.	Turn coordinator gyro speed low. Autopilot disengages and cannot be re-engaged.	Check power to turn coordinator.
Flashing NAV, REV, or APR.	Off navigation course by 50% needle deviation or more.	Use HDG mode until problem is identified. Crosscheck raw NAV data, compass heading, and radio operation.
Flashing NAV, REV, or APR with steady FAIL	Invalid radio navigation signal.	Check Nav radio for proper reception. Use HDG mode until problem is corrected.
Flashing VS	Excessive vertical speed error over selected vertical speed. Usually occurs in climb.	Reduce VS command and/or adjust power as appropriate.
Flashing GS	Off glideslope centerline by 50% needle deviation or more.	Check attitude and power. Adjust power as appropriate.
Flashing GS with steady FAIL	Invalid glideslope radio navigation signal.	Disconnect autopilot and initiate go-around or missed approach procedure. Inform ATC.
Flashing GS plus ALT.	Manual glideslope disabled.	Re-enable by pressing NAV mode button.

## Section 4 - Normal Procedures

Refer to Section 7 – Systems Description for a description of the autopilot and altitude selector and their respective modes.

The Autopilot is integrated with the Altitude Selector/Alerter and can be operated with or without data inputs from the Altitude Selector/Alerter. The autopilot ALT and VS modes are coupled to the Altitude Selector/Alerter ALT and VS outputs by simultaneously pressing the Autopilot Programmer/Computer ALT and VS buttons. Altitude Selector Vertical Speed output can be individually coupled to the autopilot through the autopilot VS mode by pressing the autopilot VS button.

### • WARNING •

The pilot must properly monitor and control the engine power to avoid stalling the airplane in autopilot altitude hold or vertical speed modes.

### • Note •

Any coupled Altitude Selector / Alerter mode can be disabled by disconnecting the autopilot.

## Autopilot and Altitude Selector Pre-Flight Tests

1. Battery Master Switch ..... ON
2. Transponder ..... ON
3. Avionics Power Switch ..... ON

Note that all autopilot annunciators, except CWS, and TRIM illuminate. After about 5 seconds, all lights will go out. When the turn coordinator gyro has reached operational RPM, the RDY annunciator will come on.

4. Altitude Selector Tests:
  - a. Altimeter ..... Set Field Elevation.
  - b. Self-Test – On power up, all annunciators come on for approximately 5 seconds and then sounds an audio tone. After the self-test is complete, press the DTA and then BAR buttons on the altitude selector.



- c. Rotate altitude selector input knob to set BARO to the nearest 0.1 inch Hg.
  - d. Push ALT button to display ALT SEL. With a flashing SEL annunciator, rotate the selector knob to input an altitude 300 to 400 feet lower or higher than the indicated altitude.
  - e. Push the VS button. Rotate the selector input knob to input the desired climb (+) or descent (-) vertical speed.
  - f. Push ALT button, ALT SEL annunciator will illuminate.
  - g. Engage autopilot HDG mode.
  - h. Simultaneously press autopilot VS and ALT buttons. Autopilot VS and ALT annunciators will illuminate.
  - i. Rotate altitude selector knob to change selected altitude to match field elevation. VS annunciator on autopilot programmer should go out when the ALT SEL setting on the altitude selector is within 100 feet of indicated altitude on altimeter. Autopilot ALT mode should remain illuminated, indicating autopilot altitude hold is engaged. If ALT engagement does not occur within 100 feet of indicated altitude, readjust BARO setting on altitude selector.
5. Autopilot Tests
- a. Heading Mode ..... TEST
    - 1.) Center the HDG bug under the lubber line on the HSI.
    - 2.) Momentarily press HDG button on autopilot Mode Selector. Note that HDG light illuminates.
    - 3.) Then rotate HDG knob on the HSI to the left then right. Note that control yokes follow movement of knob. Then return HDG bug to lubber line.
  - b. Vertical Speed ..... TEST
    - 1.) Press VS button on autopilot programmer/computer. Note that VS light illuminates VS+0.
    - 2.) Rotate the VS control knob to 500 FPM up (+5). After a short delay, the control yoke will move aft.
    - 3.) Rotate the VS control knob to 500 FPM down (-5). After a short delay, the control yoke will move forward.

- c. Altitude Hold .....TEST
  - 1.) Depress ALT button on autopilot programmer/computer. Note that ALT annunciator comes on, VS annunciator goes out, and yoke does not move.
- d. Overpower Test:
  - 1.) Grasp control yoke and input left aileron, right aileron, nose up, and nose down to overpower autopilot. Overpower action should be smooth in each direction with no noise or jerky feel.
- e. Radio Check:
  - 1.) Turn on NAV1 radio, with a valid NAV signal, and select VLOC for display on the HSI.
  - 2.) Use autopilot programmer/computer to engage NAV mode and move OBS so that VOR deviation needle moves left or right. Note that control yokes follow direction of needle movement.
- f. Autopilot Disconnect Tests:
  - 1.) Press Pilot A/P DISC/Trim Switch (control yoke). Note that the autopilot disengages. Move control yoke to confirm that pitch and roll control is free with no control restriction or binding.
  - 2.) Repeat step using Copilot A/P DISC/Trim Switch.

## In-Flight Procedures

- 1. Autopilot RDY Light .....CHECK ON
- 2. Trim airplane for existing flight conditions.
- 3. Engage desired mode by pressing mode selector button on autopilot programmer/computer.

### *Heading Mode*

- 1. Begin by selecting a heading on HSI within 10° of the current airplane heading.
- 2. Press HDG button on autopilot programmer/computer. The HDG annunciator will illuminate and the airplane will turn to the selected heading.

3. Use HSI HDG bug to make heading changes as desired.

### ***Autopilot Altitude Hold Mode***

1. Manually fly the airplane to the desired altitude and level off.

• Note •

For smoothest transition to altitude hold, the airplane rate of climb or descent should be less than 100 FPM when Altitude Hold is selected.

2. Press HDG or NAV to engage a roll mode. The associated annunciator will illuminate.

• Note •

A roll mode must be engaged prior to engaging a pitch mode.

3. Press the ALT button on the autopilot programmer/computer. The ALT annunciator will illuminate indicating that the mode is engaged and the autopilot will hold the present altitude.

• Note •

Manually flying the airplane off the selected altitude will not disengage altitude hold and the autopilot will command a pitch change to recapture the altitude when the control input is released.

4. Altitude can be synchronized to another altitude by rotating the VS knob on the programmer/computer. Clockwise rotation will increase and counterclockwise rotation will decrease altitude 20 feet for each 'click.' The maximum adjustment is  $\pm 360$  feet. Adjustments greater than 360 feet can be made by selecting VS mode and flying the airplane to the new altitude and then re-engaging ALT mode.

### ***Autopilot Vertical Speed Mode***

1. Begin by manually establishing the desired vertical speed.
2. Press HDG or NAV to engage a roll mode. The associated annunciator will illuminate.

• Note •

A roll mode must be engaged prior to engaging a pitch mode.

3. Press the VS button on the autopilot programmer/computer to engage the vertical speed mode. When the mode is engaged, the autopilot will synchronize to and hold the vertical speed at the time the mode was engaged.

• Note •

The vertical speed is displayed in 100-foot increments at the far right of the programmer/computer window next to the VS annunciation. A plus (+) value indicates climb and a negative or minus (-) value indicates descent.

4. Vertical speed can be adjusted by rotating the VS knob on the programmer/computer. Clockwise rotation increases and counterclockwise rotation decreases rate of climb (or descent) 100 FPM for each 'click.' The maximum adjustment is  $\pm 1600$  FPM.

• Note •

A flashing VS mode annunciator indicates excessive error between actual vertical speed and the selected vertical speed (usually in climb). The pilot should adjust power or reduce the commanded vertical speed as appropriate to remove the error.

### ***Altitude Pre-Select***

The altitude selector may be used to set up an altitude and vertical speed for intercept and capture. The altitude can be above or below the current altitude and the vertical speed chosen should be appropriate (climb or descent) for the altitude. Once selected, the altitude and vertical speed can be coupled to the autopilot by simultaneously pressing the autopilot ALT and VS buttons.

1. Press altitude selector DTA button to enter the data entry (ENT) mode.
2. Press altitude selector BARO button and adjust baro setting as necessary.
3. Press the ALT button to enter altitude select mode. The SEL annunciator will flash. Use the altitude selector knob to input the desired altitude in thousands of feet; for example, 5500 feet is entered as 5.5 and 10,500 is entered as 10.5.

4. Press DTA again to accept altitude entry, the ENT annunciator will go out and the SEL annunciator will stop flashing and illuminate steady indicating that the system is in the 'operate' mode.

• Note •

When the system is in the 'operate' mode, pressing the ALT button will cause the system to extinguish the SEL annunciator and display the baro corrected encoded altitude. Pressing the ALT button again will return the display to the selected altitude and the SEL annunciator will come on again.

5. Press altitude selector VS button and use altitude selector knob to input the desired vertical speed in 100 FPM increments. Turn the knob clockwise to increase vertical speed and CCW to decrease vertical speed. Positive (+) vertical speed indicates climb and negative (-) vertical speeds indicates descent. Any vertical speed from  $\pm 1$  (100 FPM) to  $\pm 16$  (1600 FPM) is selectable.

• Note •

If an altitude is selected that requires an opposite vertical speed from that selected, the system will automatically select the correct sign ('+' for climb, '-' for descent) and a vertical speed of 500 FPM.

6. After takeoff, simultaneously press the autopilot programmer / computer VS and ALT buttons to engage the autopilot VS mode and arm the autopilot altitude hold mode to capture and hold the selected altitude. If the ALR button is pressed, the system will provide alarms at 1000 feet and 300 feet from the selected altitude. As the airplane's altitude nears the selected altitude, the system automatically reduces vertical speed command in 100 FPM increments to provide a 300 FPM vertical speed at altitude capture. The system will make a smooth transition to the selected altitude and hold the selected altitude.

### ***BARO Selection***

Upon initial start-up, the altitude selector enters BARO select immediately after the self-test if it is receiving a valid altitude signal. The setting can easily be entered at this time. At other times, it is necessary to select the DTA entry and BARO modes in order to adjust the BARO setting. After initial start-up, the Baro setting can be changed at any time using the following procedure:

1. Press DTA button on altitude selector to enter the data entry mode. ENT will be annunciated.
2. Press BAR button to display the BARO setting. Repeated presses of the BAR button will toggle the display between millibars and inches Hg.

• Note •

The BARO setting can also be displayed by pressing the ALT button while in the 'operate mode' (i.e. SEL annunciator illuminated).

3. Rotate the selector knob (CW to increase setting or CCW to decrease setting). Only three digits are displayed for millibars: for a BARO setting of 952.8 mb, the display will indicate 952; and for a BARO setting of 1003.8 mb, the display will read 003. For inches Hg, the 1/100 decimal position will not be selectable or displayed; for example, a 29.92 inch Hg setting is input and displayed as 29.9.
4. Press DTA again to accept the entry.

### ***Set Decision Height (DH)***

1. Press altitude selector DTA button to enter the data entry (ENT) mode.
2. Press DH button to enter decision height with the display reading 0.0. Use the altitude selector knob to set the desired decision height to the nearest 100 ft above the desired decision height. For example, for a DH of 1160 feet, set 1200 feet.
3. Press altitude DTA button again to enter the selected DH. The display will show the selected decision height for approximately 5 seconds and then revert to ALT mode and display the altitude. The DH annunciator will remain illuminated indicating a decision height

is set. As the airplane approaches within approximately 50 feet of the decision height, the alert will sound and the DH light will flash. As the airplane passes through approximately 50 feet beyond the decision height, the alert will sound and the light will flash again.

• Note •

Pressing the DH button again will disable the DH function causing the DH annunciation to go out. Repeated activation of the DH button alternately activates and deactivates the DH mode.

***Set Altitude Alert (ALR)***

1. Press altitude selector ALR button to arm alert mode. The ALR annunciator will come on. Upon entering within 1000 feet of the altitude selected in ALT SEL, the altitude alert chime will sound in the cabin speaker and headphones and the ALR annunciator will flash. The chime will sound and the ALR annunciator will flash again as the airplane approaches within 300 feet of the selected altitude. If the airplane's altitude deviates  $\pm 300$  feet from the selected altitude, the chime will sound and the ALR annunciator will flash to indicate the condition.
2. To disable ALR, press the altitude selector ALR button again. The ALR annunciator will go out.

***GPS Tracking and GPS Approach***

1. Begin with a reliable GPS signal selected on the NAV receiver.
2. Select desired course on HSI and establish a desired intercept heading.
3. Press the NAV button on the autopilot programmer/computer twice. The NAV and GPSS mode annunciators will illuminate.

• Note •

If the course needle is at full-scale deviation, the autopilot will establish the airplane on a heading for a 45° intercept with the selected course. As the airplane approaches the course, the autopilot will smoothly shallow the intercept angle. The pilot may select an intercept angle less than the standard 45° by setting the desired intercept heading with the HSI HDG bug, pressing and holding HDG, and then pressing NAV twice on

the autopilot programmer/computer (NAV, HDG, and GPSS will be displayed). When the on-course intercept turn begins the HDG mode will disengage and the annunciator will go out.

During the intercept sequence, the autopilot operates at maximum gain and sensitivity (90% of standard rate turn). When the selected course is intercepted, course deviation needle centered, the course-tracking program is activated. The system will remain at maximum sensitivity for approximately 15 seconds while the wind correction angle is established. The maximum turn rate is then reduced to 45% standard rate. Approximately 60 seconds later, the maximum turn rate is reduced to 15% standard rate.

4. For increased sensitivity during GPS approach or if desired for enroute tracking, press the APR button on the autopilot programmer/computer. The NAV, GPSS, and APR annunciators will be illuminated. Use HDG to accomplish a procedure turn. Engage GPSS again to complete the approach.

#### ***VOR Tracking and VOR-LOC Approach***

1. Begin with a reliable VOR or VOR-LOC signal selected on the NAV receiver.
2. Select desired course on HSI and establish a desired intercept heading.
3. Press the NAV button on the autopilot programmer/computer. The NAV mode will illuminate. Course interception and tracking will be as described under GPS Tracking and GPS Approach above.
4. For station passage, set HDG bug to within 5° of selected course.

• Note •

If the HDG bug is within 5° of center and the course deviation is less than 10%, the autopilot will immediately establish the lowest level of sensitivity and limit the turn rate to a maximum of 15% of a standard rate turn.

5. For increased sensitivity during approach or if desired for enroute tracking, press the APR button on the autopilot programmer/computer. Both NAV and APR annunciators will be illuminated.



### ***Glideslope Intercept and Tracking***

1. Begin with a reliable ILS signal selected on the NAV receiver.
2. Select autopilot NAV and APR. Airplane must be within 50% needle deviation of localizer centerline.
3. Select ALT mode. Airplane must be 60% or more below the glideslope centerline during the approach to the intercept point. If the above conditions have existed for 10 seconds, GS mode will arm, the GS annunciator will come on and the ALT annunciator will remain illuminated. When glideslope intercept occurs, the ALT annunciator will go out and the system will track the glideslope.

• Note •

If approach vectoring locates the airplane too near the glideslope at the intercept point (usually the outer marker), the GS mode can be manually armed by pressing the ALT button once. Once capture is achieved, GS annunciator will come on and ALT annunciator will go out.

## **Section 5 - Performance**

There is no change to the airplane performance when the S-Tec System 55X autopilot is installed.

## **Section 6 - Weight & Balance**

There is no change to the airplane weight & balance when the S-Tec System 55X autopilot is installed.

## **Section 7 - Systems Description**

### **Autopilot**

The airplane is equipped with an S-Tec System 55X two-axis Automatic Flight Control System (Autopilot). The autopilot programmer/computer is installed in the center console radio stack.

The autopilot roll axis uses an inclined gyro in the turn coordinator case as the primary turn and roll rate sensor. In addition to the turn coordinator instrument, the roll axis computer receives signals from the HSI and the #1 NAV/GPS radio. The roll computer computes roll steering commands for turns, radio intercepts, and tracking. Roll axis

steering is accomplished by autopilot steering commands to the aileron trim motor and spring cartridge.

The pitch computer receives altitude data from the altitude encoder pressure transducer plumbed into the static system, an accelerometer, and glideslope information from the HSI and #1 NAV radio. Pitch axis command for altitude hold, vertical speed hold, and glideslope tracking is accomplished by pitch computer commands to the autopilot pitch servo.

The altitude selector provides altitude and vertical speed pre-select capability for the autopilot. A pre-programmed altitude and vertical speed can be input into the altitude selector/alerter and then coupled to the autopilot. The autopilot will then follow the selected vertical speed until the selected altitude is reached. Then the altitude selector will signal the autopilot to hold the selected altitude. The altitude selector/alerter receives uncorrected altitude data from the same altitude encoder used by the transponder. In addition to the preselect functions, the altitude selector provides altitude alert, decision height, and altitude readout.

28 VDC for autopilot and altitude selector/alerter is supplied through the 5-amp AUTOPILOT circuit breaker on the Essential Bus.

All Autopilot mode selection is performed by using the mode select buttons and VS knob on the autopilot programmer/computer in the center console. Annunciators in the programmer/computer display window annunciate modes. *Refer to Figure 1* for an illustration of the programmer/computer.

**RDY (Ready)**– Illuminates when autopilot is ready for engagement. When the airplane's Battery Master switch is turned on and the rate gyro RPM is correct, the RDY annunciator will come on indicating the autopilot is ready for the functional check and operation. The autopilot cannot be engaged unless the RDY light is illuminated.

**HDG (Heading) Mode** – When HDG is selected, the autopilot will engage the HDG mode, fly the airplane to, and hold the heading set on the HSI. Subsequent heading changes are made using the HDG knob on the HSI. For smoothest transition to HDG mode, it is recommended that the airplane be aligned to within 10° of the selected heading before engaging HDG. The HDG mode is also used in combination with the NAV mode to set up a pilot selected intercept angle to a course.

**GPSS (GPS Steering)** – Pressing NAV twice will cause the autopilot to go to GPSS for smoother tracking and transitions. When GPSS is selected, the autopilot can be switched between heading and GPSS modes of operation. In the heading mode, the converter receives a heading error signal from the heading bug on the Horizontal Situation Indicator. GPSS converts this information and sends this heading error directly to the autopilot.

In the GPSS mode, the converter receives ground speed and bank angle digital signals that are calculated and converted to a commanded turn rate. The turn rate is then scaled and converted to a DC heading error signal that is compatible with the autopilot. The end result is an autopilot that can be directly coupled to the roll steering commands produced by the GPS Navigator, eliminating the need for the pilot to make any further adjustments to the HSI course arrow.

**REV (Reverse Course)** – When REV is selected, the autopilot will automatically execute high sensitivity gain for an approach where tracking the front course outbound or tracking the back course inbound is required. The APR and REV annunciators will illuminate when REV is selected.

**APR (Approach)** – When APR is selected, the autopilot provides increased sensitivity for VOR or GPS approaches. APR may also be used to provide increased sensitivity for enroute course tracking.

**GS (Glideslope)** – The autopilot GS function will capture and track an ILS glideslope. To arm the GS function, the following conditions must be met: (1) the NAV receiver must be tuned to the appropriate ILS frequency; (2) The glideslope signal must be valid – no flag; (3) the autopilot must be in NAV/APR/ALT modes; and (4) the airplane must be 60% or more below the glideslope centerline during the approach to the intercept point, and within 50% needle deviation of the localizer centerline at the point of intercept – usually the outer marker. When the above conditions have existed for 10 seconds, the GS annunciator will illuminate indicating GS arming has occurred (ALT annunciator will remain on). When the glideslope is intercepted and captured, the ALT annunciator will go out.

**ALT (Altitude Hold), Mode** – When ALT is selected, the autopilot will hold the altitude at the time the mode was selected. Altitude hold will not engage if an autopilot roll mode is not engaged. Altitude correction for enroute barometric pressure changes may be made by rotation of the VS knob on the autopilot programmer/computer. Clockwise rotation will increase and counterclockwise rotation will decrease altitude 20 feet for each 'click.' The maximum adjustment is  $\pm 360$  feet. Adjustments greater than 360 feet can be made by selecting VS mode and flying the airplane to the new altitude and then re-engaging ALT mode.

**VS (Vertical Speed) Mode** – When VS is selected, the autopilot will synchronize to and hold the vertical speed at the time the mode was selected. Altitude hold will not engage if an autopilot roll mode is not engaged. The vertical speed is displayed in 100-foot increments at the far right of the programmer/computer window next to the VS annunciation. A plus (+) value indicates climb and a negative or minus (-) value indicates descent. Vertical speed can be adjusted by rotating the VS knob on the programmer/computer. Clockwise rotation increases and counterclockwise rotation decreases rate of climb (or descent) 100 FPM for each 'click.' The maximum adjustment is  $\pm 1600$  FPM.

## Altitude Selector / Alerter

The altitude selector / alerter provides the autopilot with an altitude preselect function, a programmable vertical speed function, as well as provides altitude alert, decision height alert, and baro corrected altitude display. The altitude selector reads and decodes altitude information from the same altitude encoder that provides altitude information to the transponder. The decoded altitude is baro corrected and then compared to the selected altitude setting. When the decoded and baro corrected altitude matches the selected altitude, the altitude selector signals the autopilot to engage the ALT hold mode. The altitude select (ALT SEL) function is operable only when the transponder and encoder are operating and then both the autopilot ALT and VS modes are selected.

The altitude selector also provides a vertical speed signal to the autopilot pitch computer that is proportional to the amplitude and direction of the selected or computed vertical speed. This signal is not used by the autopilot until the autopilot VS mode is engaged. When VS is engaged, the autopilot compares the selected vertical speed signal with the existing vertical speed derived from the autopilot's altitude transducer and maneuvers the airplane to attain the selected vertical speed. The Vertical Speed (VS) select portion of the altitude selector / alerter is showing a selected vertical speed (VS annunciator on) and the autopilot Vertical speed (VS) mode is engaged.

The altitude selector / alerter also provides Decision Height (DH) and Altitude Alert (ALR) selection. All selector function selection is made through the altitude selector/alerter. Available functions are as follows:

**DTA (Data)** – The data entry button is used to select data entry mode. The first time the DTA button is pressed the selector will enter the data entry mode, the ENT annunciator will come on, and the SEL annunciator will flash to indicate the system is ready to accept an altitude entry. To change baro (BAR) correction, Decision Height (DH), or Vertical Speed (VS), press the appropriate button on the selector and rotate the input knob at the right of the display CW to increase the displayed numbers and CCW to decrease the displayed numbers. Pull the knob out and rotate as required to change the decimal numbers.

When the system is in the ENT mode, it is not coupled to the autopilot. In this mode, the autopilot will hold the last vertical speed selected.

• Note •

It is not necessary to enter the DTA mode to change the vertical speed, if vertical speed is coupled to the autopilot. If this is the case, vertical speed changes can be made by rotating the input knob as required to obtain the new vertical speed.

While in this mode, pressing DTA a second time will toggle the system to 'operate' mode. Repeatedly pressing the DTA button will toggle the system between ENT and 'operate' mode.

**BAR (baro)** – In this mode, the baro setting used by the altitude selector may be changed. When the Altitude Selector / Alerter is initially powered, the BARO mode is displayed automatically at the completion of the self-test. At other times, it is necessary to enter the data entry mode by pressing the DTA button and then inputting a new baro correction. Pressing the DTA button a second time will return the system to the 'operate' mode.

**ALT (Altitude)** – The ALT button has two functions: Altitude Pre-select and Altitude readout.

Pre-select - When the ALT button is pressed while the system is in the Data Entry (DTA) mode the SEL annunciator will flash and a new altitude can be selected by rotating the input knob CW to increase altitude and CCW to decrease altitude in thousands of feet. Pull the knob to input altitude in hundreds of feet. For example: 5500 feet is input as 5.5. Pressing DTA again will return the system to 'operate' mode and the SEL annunciator will stop flashing with the ALT annunciator remaining on. When a preselect altitude is coupled to the autopilot by simultaneously selecting the autopilot VS and autopilot ALT, the airplane will fly at the selected vertical speed until the selected altitude is intercepted. At that time the altitude selector will command the autopilot to engage altitude hold.

Readout – When the ALT button is pressed in the 'operate' mode, the SEL annunciator will go out and the display will show the baro corrected encoder altitude. Repeated pushes of the ALT button will alternately display baro corrected encoder altitude and pre-selected altitude.

**ALR (Alert Mode)** – The ALR button enables the altitude alert system in conjunction with the ALT SEL mode. Pressing the ALR switch illuminates the ALR annunciator indicating arming of the alert mode. Upon entering within 1000 feet of the altitude selected in ALT SEL, the altitude alert chime will sound in the cabin speaker and headphones and the ALR annunciator will flash. The chime will sound and the ALR annunciator will flash again as the airplane approaches within 300 feet of the selected altitude. If the airplane's altitude deviates  $\pm 300$  feet from the selected altitude, the chime will sound and the ALR annunciator will flash to indicate the condition. The ALR function can be alternately enabled and disabled by repeatedly pressing the ALR button.

**DH (Decision Height)** – The DH button allows entry and arming of altitude alerting at a set decision height. To set a DH, first enter the data (DTA) entry (ENT) mode, press the DH button, and rotate the selector knob to input the desired decision height to the nearest 100 feet above the specified decision height. For example, for a DH of 1160 feet set 1.2 (1200 feet). After setting the desired decision height, press the DTA button again to accept the entered DH. The display will show the selected DH for approximately 5 seconds and then revert to Alt mode until the selected DH is reached during descent. The DH annunciator will remain illuminated indicating a decision height is set. As the airplane approaches within approximately 50 feet of the decision height, the alert will sound and the DH light will flash. As the airplane passes through approximately 50 feet beyond the decision height, the alert will sound and the light will flash again. Pressing the DH button again will disable the DH function causing the DH annunciation to go out. Repeated activation of the DH button alternately activates and deactivates the DH mode.

**VS (Vertical Speed)** – At initial start up, after self-test, pressing the Altitude Selector / Alerter VS button enables vertical speed selector mode. The initial vertical speed will be set at + 2 indicating a climb at 200 feet per minute. Rotating the selector input knob will change the selected vertical speed in 100 FPM increments. Rotate CW to increase vertical speed or CCW to Decrease vertical speed. The maximum vertical speed is  $\pm 1600$  FPM ( $\pm 16$ ). Zero vertical speed is not selectable.

The vertical speed display is the only Altitude Selector / Alerter function available in the 'operate' mode. Therefore, vertical speed changes can be commanded by rotating the selector input knob. Vertical speeds can also be entered in the data (DTA) entry (ENT) mode by pressing the VS button and using the selector input knob to enter a new vertical speed. The DTA button must be pressed again to accept the new vertical speed and enter the 'operate' mode.

The Altitude Selector / Alerter VS mode can be disabled by pressing the Altitude Selector / Alerter MAN button.

**MAN (Manual)** – Vertical Speed selection can be completely decoupled from the autopilot system by depressing the Altitude Selector / Alerter MAN button.



**Pilot's Operating Handbook and  
FAA Approved Airplane Flight Manual  
Supplement  
for**

# **Approved Oxygen Systems**

When supplemental oxygen is required by the applicable operating rules (FAR Part 91 or FAR Part 135), this Supplement is applicable and must be inserted in the Supplements Section (Section 9) of the Cirrus Design SR22 Pilot's Operating Handbook (Handbook). Information in this supplement either adds to, supersedes, or deletes information in the basic Handbook.

• Note •

This POH Supplement Revision dated 10-10-03 supersedes and replaces the original issue of this supplement dated 12 December, 2000.

FAA Approved Joseph C. Prather Date Oct 10 2003  
Royace H. Prather, Manager  
Chicago Aircraft Certification Office, ACE-115C  
Federal Aviation Administration

## Section 1 - General

This supplement lists the approved portable oxygen systems that may be used in the SR22 when supplemental oxygen is required by the applicable operating rules, as well as provides mounting instructions and general operating procedures for all approved systems.

### **Section 2 - Limitations**

Smoking is not permitted in the SR22.

The following portable oxygen systems and dispensing units are approved for use in the Cirrus Design SR22:

Model	Capacity	Supplier	Dispensing Units
XCP-682	682 L	Mountain High Equip. & Supply	Mask (1 minimum), Cannula,
XCP-415	415 L	Redmond, OR	A4 Flowmeters Only (use mask or std. cannula scale only)
XCP-180	180 L	mhoxygen.com	<b>Do not use A3 flowmeters</b>

The system must be configured so that at least one mask capable of covering the nose and mouth is available for use.

If nasal cannulas are provided in addition to the mask(s), the instruction sheet provided by the cannula manufacturer must be affixed to the tubing on each cannula and available to each user. The instructions must contain the following information:

- A warning against smoking while oxygen is in use;
- An illustration showing the correct method of donning; and
- A visible warning against use of the cannula with nasal obstructions or head colds with resultant nasal congestion.

The oxygen bottle must be secured in the right front seat so that the pilot can view the oxygen pressure gage and operate the regulator. When the oxygen bottle is installed, the seat may not be occupied in flight and the maximum occupancy is reduced by one.

Oxygen storage bottles were hydrostatically tested at manufacture and the date stamped on the bottle. The storage bottle must be hydrostatic tested and recertified every 5 years.

## Section 3 - Emergency Procedures

### Smoke and Fume Elimination

In addition to the procedures outlined in the basic Handbook, pilot and passengers should don cannulas or masks and use oxygen at the maximum flow rate until smoke and fumes have cleared.

## Section 4 - Normal Procedures

• Note •

*Refer to Figure 2 – Oxygen Duration for duration at various altitudes and passengers using oxygen.*

### Preflight

1. Oxygen Bottle (right front seat) ..... Check Properly Secured
2. Oxygen Masks or Cannulas ..... Connected to Regulator
3. Oxygen Pressure Gage ..... Green Arc
4. Oxygen Shutoff Valve ..... OFF

### Before Starting Engine

1. Passengers ..... Brief on Oxygen System Operation

• Note •

Briefing to include oxygen mask/cannula donning, flowmeter adjustment, and connection to oxygen bottle regulator.

### Climb

As airplane approaches altitude requiring oxygen:

1. Pilot and passengers ..... Don Masks or Cannulas
2. Oxygen Shutoff Valve ..... ON
3. Flowmeters ..... Adjust flow for final cruise altitude

• **WARNING** •

Set A4 flowmeter using standard cannula or mask scale. **Do not use scale for oxygen conserving.**

## Descent

After airplane descends through altitude requiring oxygen:

1. Oxygen Shutoff Valve.....OFF
2. Pilot and passengers ..... Stow Masks or Cannulas

## Section 5 - Performance

No change from basic Handbook.

## Section 6 - Weight & Balance

The weight, arm, and moment for fully charged systems (1800 – 2200 psi) is provided in the following table:

Model	Weight - lb	Arm	Moment/1000
XCP-682 (682 Liter)	14.00	143.5	2.01
XCP-415 (415 Liter)	10.25	143.5	1.47
XCP-180 (180 Liter)	4.50	143.5	0.65

## Section 7 - System Description

Refer to approved system manufacturer's data for a description of the equipment, cleaning instructions, and specific operational instructions.

### Mounting Instructions

The oxygen bottle must be properly mounted in the right front passenger seat using the cylinder harness supplied with the system. When properly mounted and secured, the pilot will be able to view the oxygen pressure gage and operate the shutoff valve. See Figure 1 for mounting instructions.

### INITIAL INSTALLATION

- 1 Clip strap to triangular loop as shown in Detail A. Route strap over headrest, down the back of the seat, and forward between the cushion and seat back. Clip strap to lower triangular loop. Tighten strap with cinch.

**Note** Prior to installing bottle the first time, the horizontal straps will be disassembled in order to pass the loose ends through the loops on the Tuff Pack Bag. Be sure to note the strap routing through the buckle and cinch during disassembly to aid in reassembly.

- 2 Route loose end of strap around the seat back, through rectangular loops on forward side of bottle, as shown in Detail B, through the male buckle half, and through the cinch, as shown in Detail C. Insert male buckle half into female buckle half and tighten strap at cinch.
- 3 Same as step 2.

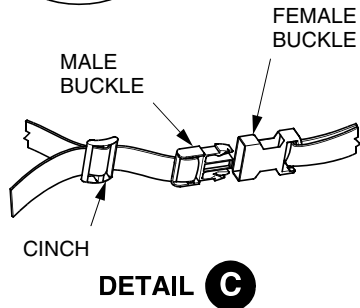
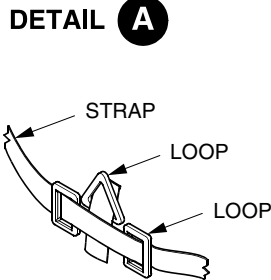
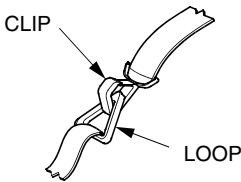
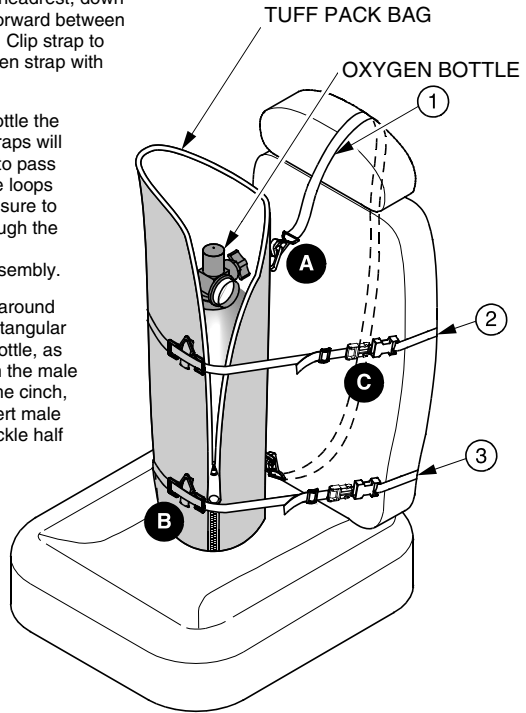

SR22\_FM09\_1081

Figure - 1  
Oxygen Bottle Mounting

**OXYGEN DURATION - HOURS**  
**Fully Charged System**  
(1800 psig at 70° F)

System Typical (Liters)	Number of Persons Using O <sub>2</sub>	Altitude ~ Feet		
		10,000	15,000	18,000
XCP-180 (134)	1	2.23	1.49	1.24
	2	1.12	0.75	0.62
	3	0.74	0.50	0.41
XCP-415 (371)	1	6.18	4.12	3.43
	2	3.09	2.06	1.71
	3	2.06	1.37	1.14
XCP-682 (609)	1	10.15	6.77	5.64
	2	5.08	3.39	2.82
	3	3.38	2.26	1.88

Durations assume typical flow rate of 1.0 liter/minute at 10,000 feet pressure altitude.

**Figure - 2**  
**Oxygen Duration**

**Pilot's Operating Handbook and  
FAA Approved Airplane Flight Manual  
Supplement  
for**

**BF Goodrich WX500 Stormscope  
Sensor**

When the BF Goodrich Aerospace WX500 Stormscope Sensor is installed in the Cirrus Design SR22, this Supplement is applicable and must be inserted in the Supplements Section (Section 9) of the Cirrus Design SR22 Pilot's Operating Handbook. This document must be carried in the airplane at all times. Information in this supplement either adds to, supersedes, or deletes information in the basic SR22 Pilot's Operating Handbook.

FAA Approved

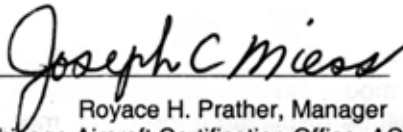

Date DEC 12 2000

Royace H. Prather, Manager  
Chicago Aircraft Certification Office, ACE-115C  
Federal Aviation Administration

## **Section 1 General**

This airplane is equipped with a BF Goodrich Aerospace WX500 Stormscope Sensor. The stormscope sensor output is displayed on the ARNAV ICDS 2000 Multi-function display (MFD).

## **Section 2 - Limitations**

1. Stormscope information displayed on the ARNAV ICDS 2000 Multi-function display is FOR REFERENCE ONLY and must not be used for navigation.

## **Section 3 - Emergency Procedures**

There is no change to the basic POH Emergency Procedures when the WX500 stormscope is installed.

## **Section 4 – Normal Procedures**

*Refer to the ARNAV ICDS 2000 Pilot's Operations Handbook (572-0550D) dated December 1999 for detailed operating procedures and specific display information.*

### **Stormscope Status Box**

When the Stormscope is on, system status will be displayed in the Stormscope status box in the upper left corner of the map page.

**HDG or TRK** – HDG will be displayed if an external heading input is available. If HDG (heading) is displayed bearing to the strike will be referenced to the airplane heading (direction nose is pointing). If TRK (track) is displayed the bearing to the strike will be referenced to the airplane track (direction airplane is traveling). Normally, the system will plot strikes with reference to heading.

**STRK or CELL** – STRK will be displayed if the Strike mode is selected. In this mode, individual strikes are plotted using the 'X' symbol. CELL will be displayed if the CELL mode is selected. In the Cell mode a '+' symbol is plotted for associated strikes.

**RATE** – The number of strikes per minute for the selected mode and scale is indicated in a small window below the status line.



## Section 5 - Performance

There is no change to the airplane performance when the WX500 stormscope is installed.

## Section 6 - Weight & Balance

Weight and balance data for the WX500 stormscope is provided with the Equipment List for each delivered airplane.

## Section 7 - Systems Description

• Note •

*Refer to the ARNAV ICDS 2000 Pilot's Operations Handbook (572-0550D) dated December 1999 for detailed operating procedures and specific display information.*

The BF Goodrich Aerospace WX-500 Weather Mapping Sensor (Stormscope) detects electrical discharges associated with thunderstorms and displays the activity on the ARNAV ICDS 2000 Multi-function Display. The system consists of an antenna located on top of the fuselage just forward of the rear window and a processor unit mounted under the aft baggage floor. The antenna detects the electrical and magnetic fields generated by intra-cloud, inter-cloud, or cloud to ground electrical discharges occurring within 200 nm of the airplane and sends the "discharge" data to the processor. The processor digitizes, analyzes, and converts the "discharge" signals into range and bearing data and communicates the data to the MFD every two seconds. The Stormscope processor is powered 28 VDC through the 3-amp STORMSCOPE circuit breaker on the Avionics Non-essential Bus.

Intentionally Left Blank

**Pilot's Operating Handbook and  
FAA Approved Airplane Flight Manual  
Supplement  
for**

# **Goodrich SkyWatch SKY497 Traffic Advisory System**

When the Goodrich SkyWatch 497 is installed in the Cirrus Design SR22, this POH Supplement is applicable and must be inserted in the Supplements Section (Section 9) of the appropriate Cirrus Design Pilot's Operating Handbook. This document must be carried in the airplane at all times. Information in this supplement adds to, supersedes, or deletes information in the basic Pilot's Operating Handbook.

FAA Approved Joseph C. Miess Date Aug 20 2001  
Royace H. Prather, Manager  
Chicago Aircraft Certification Office, ACE-115C  
Federal Aviation Administration

## **Section 1 - General**

This airplane is equipped with a Goodrich SkyWatch SKY497 Traffic Advisory System to advise the pilot of transponder-equipped aircraft that may pose a collision threat. SkyWatch advisory information is displayed on the GARMIN 430 display. The display indicates relative range, bearing, and altitude of intruder aircraft. Aural warnings are integrated into the airplane's audio system.

## **Section 2 - Limitations**

### **• WARNING •**

SkyWatch can only detect aircraft that are equipped with operating transponders.

1. Traffic information shown on the GARMIN 430 displays is provided as an aid in visually acquiring traffic. Pilots must maneuver the aircraft based only upon ATC guidance or positive visual acquisition of conflicting traffic.
2. If the pilot is advised by ATC to disable transponder altitude reporting, the SkyWatch must be turned OFF.
3. The Goodrich SkyWatch Traffic Advisory System Model SKY497 Pilot's Guide P/N 009-10801-001 Rev B (6/6/00) or later must be available to the pilot during flight with the SkyWatch operating.
4. The GARMIN 400 Series Pilot's Guide Addendum for "Display Interface for Traffic and Weather Data" P/N 190-001140-10 Rev B or later revision must be available to the pilot during flight with the SkyWatch operating.

## **Section 3 - Emergency Procedures**

No Change

## Section 4 - Normal Procedures

### After Engine Start

1. Avionics Power Switch .....ON
2. SkyWatch will turn on, complete a self-test, and then enter the STBY mode.

• Note •

During the takeoff run, SkyWatch will automatically switch to operational mode approximately 8 seconds after 35 KIAS is achieved.

During the landing roll out, SkyWatch will automatically switch back to STBY approximately 24 seconds after the airplane slows to 35 KIAS or below.

3. *Refer to the GARMIN 400 Series Pilot's Guide Addendum for "Display Interface for Traffic and Weather Data" P/N 190-001140-10 Rev B for additional SkyWatch operational data not included in this supplement.*

### Operator Initiated Control of SkyWatch

#### **Self-Test**

In addition to the power-up self-test, an automatic self-test is performed several times each minute. If the SkyWatch is in STBY or FAILED modes, an operator initiated self-test may be performed using the GNS 430 controls as described below:

1. Rotate the small PUSH CRSR knob to select the Traffic / Weather page.
2. From the Traffic Screen, press the MENU key to select the Menu page.
3. Rotate the small PUSH CRSR knob to select SELF TEST and then press the ENT key.

#### **Switch to Normal from the Standby Screen**

SkyWatch must be switched out of STBY to display traffic information. The ability to switch out of STBY on the ground is useful for scanning the airspace around the airfield prior to takeoff. Using the GNS 430 controls:

1. Turn the cursor on and highlight STBY.
2. Use the small PUSH CRSR knob to select OPER?
3. Press the ENT key to place SkyWatch in the OPER (operational) mode. SkyWatch will switch into the 6 nmi display range.

### ***Switch into Standby from the Traffic Screen***

SkyWatch cannot be switched to Standby while airborne. With the airplane on the ground, use the GNS 430 controls as described below:

1. Turn the cursor on and highlight OPER.
2. Use the small PUSH CRSR knob to select STBY?
3. Press the ENT key to place SkyWatch in the STBY (standby) mode.

### ***Change Altitude Display***

1. From the Traffic Screen, turn the cursor on, highlight the current mode, and use the small PUSH CRSR knob to cycle through the options.
2. With each turn, the display changes to display the traffic in the selected display range (ABV, look up; NRM, normal; BLW, look down; or UNR, unrestricted). *Refer to the Goodrich SkyWatch Traffic Advisory System Model SKY497 Pilot's Guide P/N 009-10801-001 Rev B (6/6/00) or later for information regarding the display ranges.*

## **Respond to Traffic Advisories**

1. When the SkyWatch issues a TA (Traffic Advisory), visually scan outside for the intruder aircraft. Call ATC for Guidance. If you visually acquire the intruder aircraft, use normal right-of-way procedures to maintain separation.

• Note •

Do not maneuver solely on traffic information shown on the display. Information shown on the display is provided as an aid in visually acquiring traffic - It is not a replacement for ATC and See & Avoid techniques.

## Section 5 - Performance

No Change

## Section 6 - Weight & Balance

SkyWatch adds the following optional (Sym = O) equipment at the weight and arm shown in the following table.

ATA/Item	Description	Sym	Qty	Part Number	Unit Wt	Arm
34-01	SkyWatch Inverter	O	1	14484-001	0.5	118.0
34-02	SkyWatch Antenna Instl.	O	1	14477-001	2.3	150.5
34-03	SkyWatch Track Box	O	1	14477-050	10.0	140.0
34-04	SkyWatch Wiring Instl	O	1	14479-001	2.0	145.0

## Section 7 - Systems Description

The SkyWatch model SKY497 is an airborne Traffic Advisory System (TAS). SkyWatch monitors a radius of approximately 6 nautical miles around the aircraft by interrogating transponders in the monitored area and determining if a collision threat exists. To determine if a collision threat exists, SkyWatch calculates the range, altitude, bearing, and closure rate of all transponder equipped aircraft within the 6 nautical mile range. When SkyWatch detects an intruder aircraft within .55 nautical mile horizontal distance and a  $\pm 800$  ft relative altitude or detects an intruder aircraft is on a course that will intercept the SkyWatch airplane's course within 20 seconds (non-altitude reporting intruder aircraft) or 30 seconds (altitude reporting intruder aircraft), SkyWatch will issue a Traffic Advisory (TA). Traffic Advisories are indicated on the GNS 430 displays and aural "Traffic, Traffic" warnings are announced in the headphones and cabin speaker.

SkyWatch may be pilot controlled through the GNS 430 controller. STBY (standby), OPER (operational), and SELF TEST modes as well as altitude display (ABV, look up; NRM, normal: BLW, look down; or UNR, unrestricted) can be selected.

The SkyWatch System consists of a Transmitter Receiver Computer (TRC) installed under the copilot's seat just forward of the spar tunnel and a directional antenna installed on the airplane exterior above the cabin. The system also utilizes inputs from the altitude encoder, the aircraft heading system (gyro slaving amplifier), and a speed switch plumbed into the pitot system. Electrical power for system operation is 28 vdc supplied through the 5-amp SKYWATCH Circuit Breaker on the Avionics Non-Essential bus.

• Note •

*Refer to the Goodrich SkyWatch Pilot's Guide (P/N 009-10801-001) for a description of the SkyWatch System.*

*Refer to the GARMIN Addendum for "Display Interface for Traffic and Weather Data" P/N 190-001140-10 for additional operational information and a display description.*



Pilot's Operating Handbook and  
FAA Approved Airplane Flight Manual  
Supplement  
For

# Avidyne EX5000C Multifunction Flight Display

## Software Partnumbers

530-00112-000, 530-00117-000, 530-00148-000, 530-00162-000

When the Avidyne FlightMax EX5000C 700-00004-XXX-() Multi-Function Flight Display (MFD) with software partnumber 530-00112-000 or later is installed in the Cirrus Design SR22, this POH Supplement is applicable and must be inserted in the Supplements Section (Section 9) of the Cirrus Design SR22 Pilot's Operating Handbook. This document must be carried in the airplane at all times. Information in this supplement adds to, supersedes, or deletes information in the basic SR22 Pilot's Operating Handbook.

• Note •

This POH Supplement Revision 09-27-04 supersedes and replaces the Revision 1 issue of this supplement dated 07-30-02. This revision adds required data for the optional XM Satellite Weather System and the CMax Approach Charts function available for the FlightMax EX5000C MFD.

FAA Approved Joseph C. Mies Date Sept 27 2004  
for Royace H. Prather, Manager  
Chicago Aircraft Certification Office, ACE-115C  
Federal Aviation Administration

## Section 1 - General

This airplane is equipped with an Avidyne FlightMax EX5000C 700-00004-XXX-() Multi-Function Flight Display (MFD). The MFD is a 10.4-inch landscape-oriented display mounted in the instrument panel. The MFD provides supplemental display of situational and navigation information to the pilot. This is accomplished by showing an icon representing the airplane against a moving map. The MFD accepts data from a variety of sources, including the GPS sensors, the WX-500 Stormscope, and the SkyWatch Traffic Advisory System. The unit is organized around logical grouping of information presented on “Pages.”

• Note •

The Avidyne system software partnumber for this installation is 530-00112-000 or later.

The MAP page is the primary page and presents the pilot with a pictorial of the aircraft position, flight plan, and nearby lightning as well as traffic. This data is overlaid on a moving map background with terrain, inland and coastal water bodies, airspace, airports, and navigational aids. Buttons and knobs on the MFD bezel allow the pilot to control the presentation of information on the moving map.

The TRIP page provides the pilot with the remaining legs of the active flight plan in tabular format. Additional navigational data presented on this page in graphic and numeric form aids the pilot in understanding aircraft position relative to the active flight plan.

The NEAREST page provides a list and relative position of navigational items of interest, including nav aids and airports. From this page, the pilot can get more detail on an item by accessing the INFO page.

The CHECKLIST pages provide electronic displays of checklists. The checklists provide POH Normal Procedures Checklists, POH Emergency Procedures Checklists, and essential POH Performance Data.

The SYSTEM SETUP pages allow the pilot to set user preferences for the display and view on-board database version and validity dates.

For additional information, *Refer to the Avidyne FlightMax EX5000C Pilot's Guide*, P/N 600-00108-000, Revision 03 or later.



Figure - 1

Avidyne FlightMax Multifunction Display

## Section 2 - Limitations

1. The moving map display must not be used as the primary navigation instrument. The moving map display provides visual advisory of the airplane's GPS position against a moving map. The information supplements CDI course deviation and information provided on the GPS navigator.
2. Use of Map page during IFR flight requires an IFR approved GPS receiver installation operated in accordance with applicable limitations.
3. Under no circumstances should the Map page terrain representations be used as a basis for terrain avoidance.
4. The Avidyne electronic checklists display supplements the Pilot Operating Handbook checklists and is advisory only. The electronic checklists must not be used as the primary set of on-board airplane checklists.
5. The MFD interfaces with separately approved sensor installations. Adherence to limitations in the appropriate sensor installation POH Supplements is mandatory.
6. Traffic information shown on the Map page display is provided to the pilot as an aid to visually acquire traffic. Pilots should maneuver their aircraft based only on ATC guidance or positive visual acquisition of the conflicting traffic. Maneuver should be consistent with ATC instructions. No maneuvers should be made based solely on a traffic advisory.
7. Do not use the optionally installed XM Satellite Weather System for navigation of the aircraft. The XM Satellite Weather System is intended to serve as a situational awareness tool only.
8. Do not use the CMax Approach Charts function for navigation of the aircraft. The CMax Approach Charts function is intended to serve as a situational awareness tool only. The electronic approach charts must not be used as the primary set of on-board approach charts.
9. The Avidyne FlightMax EX5000C Pilot's Guide, P/N 600-00108-000, Revision 03 or later, must be available to the pilot during all flight operations.

## Section 3 - Emergency Procedures

No Change

## Section 4 - Normal Procedures

### Activate MFD

1. MFD Circuit Breaker ..... IN
2. Battery Master Switch.....ON
3. Avionics Power Switch .....ON
4. At MFD prompt, any Key.....PRESS
5. MFD Soft Keys.....SET for Desired Operation

### MAP

• Note •

Upon startup, the map is linked to GPS1 or GPS2 depending upon the setting selected with the SWAP soft key in Setup mode. Normally, the display should be linked to GPS1; however, GPS2 can be selected if GPS1 should fail. When the Map view is set to North Up, traffic and weather depictions are oriented north up, which may cause confusion. Pressing the View bezel key will cycle the Map display to a heading up orientation. If a Traffic Advisory (TA) occurs, pressing the Message Ack bezel key will display a heading up traffic display and suppress the display of other, non-traffic items.

### Deactivate MFD

1. Avionics Power Switch .....OFF  
or
2. MFD Circuit Breaker .....PULL

## Section 5 - Performance

No Change

## Section 6 - Weight & Balance

Installation of the Avidyne FlightMax MFD adds the following optional (Sym = O) equipment at the weight and arm shown in the following table. The adapter plate is used only on most installations where the MFD was installed by Service Bulletin.

ATA / Item	Description	Sym	Qty	Part Number	Unit Wt	Arm
34-01	Avidyne FlightMax MFD	O	1	700-00004-XXX	6.4	121.8
34-02	Avidyne Adapter Plate	O	1	-	0.4	123.2
34-03	Engine Sensors	O	11	-	1.0	75.0
34-04	Engine Sensor Unit	O	1	14843-001	1.1	118.0
34-05	Engine Sensor Harness	O	1	15030-001	0.9	92.0
34-06	Engine Sensor Cabin Harness	O	1	15032-001	2.1	108.0
34-07	XM Weather Receiver	O	1	16121-001	1.7	114.0

## Section 7 - Systems Description

• Note •

This supplement provides a general description of the Avidyne FlightMax *EX5000C* MFD, its operation, and airplane interface. For a detailed description of the MFD, *refer to the Avidyne FlightMax EX5000C Pilot's Guide*, P/N 600-00108-000 Rev 03, Revision 03 or later.

### Navigation

Data associated with the moving map is found on four pages: Map, Nearest, Trip, and Info. The MFD contains a Jeppesen NavData database that is available for display on the map page. In conjunction with GPS-supplied position information, an ownship symbol is superimposed on the moving map and positioned relative to the NavData information. GPS can also supply the active flight plan for display on the moving map. Terrain data is supplied by a USGS terrain database stored within the MFD and updated only on an as needed basis.

The Jeppesen NavData database provides data on airports, approaches, VORs, NDB, intersections, airspace definitions, and frequencies. North American and international databases are available. Database information can be updated through the USB port on the front bezel.

The navigation data on the moving map display are based on databases that are updated periodically. Database updates are available from Avidyne on 28-day cycle subscriptions. Expired databases are clearly stated to the pilot through messages during system startup and on the System Setup page. The warning can only be removed by updating the database.

NOAA man-made obstruction database information provides data on man-made obstacles over 200-feet AGL. This data is available for North America only and can be updated through the USB port on the front bezel. The obstacle data on the moving map display are based upon databases that are updated periodically. Obstacle database updates are available from Avidyne on 56-day cycle subscriptions. Expired databases are clearly stated to the pilot through messages during system startup and on the System Setup page. The warning can only be removed by updating the database.

Using the Jeppesen NavData data and the GPS-supplied position, the MFD can provide the pilot with the nearest 25 airports or nav aids within 100 nm, depending upon pilot selection. This information is presented on the Nearest page.

More detail on a particular airport is also generated from the Jeppesen NavData data and is available for viewing on the Info page.

Flight plan data supplied by the GPS system provides the pilot with a tabular form of the remaining legs in the active GPS flight plan. This information is viewable on the trip page and includes a CDI for added enroute navigation aiding.

Flight Plan data is transmitted to the MFD from an external GPS navigator. Some installations do not support depictions of curved flight paths. In these cases, curved flight path segments will be depicted as straight lines. The GPS navigator and HSI are to be used during approach procedures.

## Checklist

The Normal and Emergency Procedures Checklists in the MFD are interactive. The pilot is able to check off each step as it is accomplished. Once a step is checked off, it changes color so that a record of completed steps is visually recorded. Additionally, checklist steps can be un-checked, the entire checklist can be reset, and confirmation of a completed checklist is indicated.

Normal Procedures checklist steps in the MFD are abbreviated from the POH procedures and Notes, Cautions, and Warnings have been removed. The following Normal Procedures Checklists are provided in the Checklist Pages of the MFD:

- Airspeeds for Normal Operations
- Before Takeoff
- In Flight
- Landing/Shutdown

Emergency Procedures checklist steps in the MFD are abbreviated from the POH procedures and Notes, Cautions, and Warnings have been removed. The Emerg Checklist soft key is always displayed on the MFD. The following Emergency Procedures Checklists are provided in the Checklist Pages of the MFD:

- Emergency Airspeeds
- Ground Emergencies
- In-Flight Emergencies
- Landing Emergencies
- System Malfunctions

Performance data in the MFD are derived directly from the POH data. The following Performance data and Charts are provided in the Checklist Pages of the MFD:

- Crosswind Chart
- Takeoff Distance Chart
- Selected Cruise Settings
- Landing Distance Chart



## Setup

Various System Setup pages allow the pilot to set user preferences for system operation. In addition to listing the software version identification information and database validity dates, the System Setup pages allow access to several pages for preference selection. Additionally, the System Setup pages provide a means to initiate self test of the traffic and lightning sensors. The following preferences can be set:

- Airport Settings page – selections for displaying airport type, runway surface type, minimum runway lengths on moving map.
- Declutter Settings page – selections for defining the base map detail when changing display range.
- System Time – selection of system time zone and map page menu timeout options.
- DataBlock Edit page – selection of data to be displayed in the datablock window of the Map page.
- Swap GPS 2 – Selecting this soft key in Setup will swap data display from GPS 1 to GPS 2 in the event of a failure of GPS 1. Normally, GPS 1 should be used; however, GPS 2 may be used as a backup when necessary.

## Engine Instruments (Optional Installation)

• Note •

For a detailed description of Engine Instruments, *refer to Avidyne FlightMax EX5000C Pilot's Guide, P/N 600-00108-000, Revision 03 or later.* MFD software partnumber 530-00117-000 or later is required for installation of Engine Instruments.

The optional Engine page provides the pilot with engine parameters depicted on simulated gauges and electrical system parameters located in a dedicated region within in the EX5000C MFD display. An Engine Sensor Unit interfaces with engine-mounted sensors, some of which are shared with the standard airplane gauges, and provide data to the MFD for display.

The Engine Instruments system is powered by 28 VDC supplied through the 5-amp Engine Instruments breaker on the Main Bus 1.

## XM Satellite Weather System (Optional Installation)

### • WARNING •

Do not use the XM Satellite Weather System for navigation of the aircraft. The XM Satellite Weather System is intended to serve as a situational awareness tool only.

#### • Note •

For a detailed description of the XM Satellite Weather System, refer to *Avidyne FlightMax EX5000C Pilot's Guide, P/N 600-00108-000, Revision 03 or later*. MFD software partnumber 530-00162-000 or later is required for installation of XM Satellite Weather System.

The optional XM Satellite Weather System enhances situational awareness by providing the pilot with real time, graphical weather information. The XM antenna, integrated with the COM1 antenna, receives weather information from dual-redundancy satellites. This signal is sent to the XM receiver, installed in the co-pilot side of the instrument console, which interprets and overlays the weather data on the MAP page of the EX5000C MFD.

The XM Satellite Weather System is powered by 28 VDC supplied through the 3-amp Weather/Stormscope breaker on the Non-Essential Bus.

#### • Note •

Subscription to a XM Satellite Weather System Service Package is required for operation. Contact XM Satellite Radio at 800.985.9200 for subscription information.

Once activated, the XM Satellite Weather System will overlay the following weather data on the EX5000C MFD:

- NEXRAD Radar
- METARs
- SIGMETs
- AIRMETs
- TFRs
- Lightning Strikes

## CMax Approach Charts (Optional Installation)

### • WARNING •

Do not use the CMax Approach Charts function for navigation of the aircraft. The CMax Approach Charts function is intended to serve as a situational awareness tool only. The electronic approach charts must not be used as the primary set of on-board approach charts.

### • Note •

For a detailed description of the CMax Approach Charts System, refer to *Avidyne FlightMax EX5000C Pilot's Guide, P/N 600-00108-000, Revision 03 or later*. MFD software partnumber 530-00162-000 or later is required for installation of CMax Approach Charts.

The optional CMax Approach Charts function allows the pilot to view terminal procedure chart data on the EX5000C MFD. If the chart is geo-referenced, an ownship symbol and flight plan legs can be overlaid on the chart to further enhance the pilot's situational awareness. Most approach charts and airport diagrams are geo-referenced; most arrival, departure, and miscellaneous charts are not. The CMax installation is entirely software dependant. No additional hardware is required.

### • Note •

Subscription to JeppView Electronic Airway Manual chart service is required for operation. Contact Jeppesen Sanderson, Inc. at 800.621.5377 for subscription information.

Intentionally Left Blank

**Pilot's Operating Handbook and  
FAA Approved Airplane Flight Manual  
Supplement  
for  
Cirrus Design SR22 Airplanes Registered in  
Canada**

1. This supplement is required for operation of Cirrus Design SR22 airplanes when registered in Canada. This supplement must be attached to the applicable SR22 FAA-approved Airplane Flight Manual (P/N 13772-001 Change 2 dated 24 January 2002 or later FAA-approved Flight Manual revision).
2. The information contained within this supplement is to be used in conjunction with the basic AFM and supplements. The information contained herein supplements or supersedes that in the basic manual and approved supplements only in those areas indicated.
3. Compliance with the limitations contained in the basic manual and approved supplements is mandatory.
4. Foreign operating rules and any references to such rules in the basic manual and approved supplements are not applicable in Canada. The aircraft must be equipped and operated in accordance with Canadian operating requirements. *Refer to the Canadian Aviation Regulations (CARs)* for the operating rules and equipment requirements that do pertain to operations in Canada.

• Note •

A Kinds of Operating Equipment List (KOEL) may not necessarily apply in Canada.

5. Conversion charts are included with this supplement that facilitate conversions between metric, Imperial and U.S. units of measure.

FAA Approved  
On Behalf Of  
Transport Canada

 Date 6/05/02

for Royace H. Prather, Manager  
Chicago Aircraft Certification Office, ACE-115C  
Federal Aviation Administration

# Weight Conversion

## Kilograms Into Pounds Kilograms En Livres

kg	0	1	2	3	4	5	6	7	8	9
	lb.	lb.	lb.	lb.	lb.	lb.	lb.	lb.	lb.	lb.
0	0.0	2.2	4.4	6.6	8.8	11.0	13.2	15.4	17.6	19.8
10	22.0	24.3	26.5	28.7	30.9	33.1	35.3	37.5	39.6	41.9
20	44.1	46.3	48.5	50.7	52.9	55.1	57.3	59.5	61.7	63.9
30	66.1	68.3	70.5	72.8	75.0	77.2	79.4	81.6	83.8	86.0
40	88.2	90.4	92.6	94.8	97.0	99.2	101.4	103.6	105.8	108.0
50	110.2	112.4	114.6	116.9	119.0	121.3	123.5	125.7	127.9	130.0
60	132.3	134.5	136.7	138.9	141.1	143.3	145.5	147.7	149.9	152.1
70	154.3	156.5	158.7	160.9	163.1	165.4	167.6	169.8	172.0	174.1
80	176.4	178.6	180.8	183.0	185.2	187.4	189.6	191.8	194.0	196.2
90	198.4	200.6	202.8	205.0	207.2	209.4	211.6	213.9	216.0	218.3
100	220.5	222.7	224.9	227.1	229.3	231.5	233.7	235.9	238.1	240.3

## Pounds Into Kilograms Livres En Kilogrammes

lb.	0	1	2	3	4	5	6	7	8	9
	kg	kg	kg	kg	kg	kg	kg	kg	kg	kg
0	0.0	0.5	0.9	1.4	1.8	2.3	2.7	3.2	3.6	4.1
10	4.5	5.0	5.4	5.9	6.4	6.8	7.3	7.7	8.2	8.6
20	9.1	9.5	10.0	10.4	10.9	11.3	11.8	12.2	12.7	13.2
30	13.6	14.1	14.5	15.0	15.4	15.9	16.3	16.8	17.2	17.7
40	18.1	18.6	19.1	19.5	20.0	20.4	20.9	21.3	21.8	22.2
50	22.7	23.1	23.6	24.0	24.5	24.9	25.4	25.9	26.3	26.8
60	27.2	27.7	28.1	28.6	29.0	29.5	29.9	30.4	30.8	31.3
70	31.8	32.2	32.7	33.1	33.6	34.0	34.5	34.9	35.4	35.8
80	36.8	36.7	37.2	37.6	38.1	38.6	39.0	39.5	39.9	40.4
90	40.8	41.3	41.7	42.2	42.6	43.1	43.5	44.0	44.5	44.9
100	45.4	45.8	46.3	46.7	47.2	47.6	48.1	48.5	49.0	49.4

Figure - 1  
Sheet 1 of 2

# Weight Conversion

Kilograms x 2.205 = Pounds

Pounds x 0.454 = Kilograms

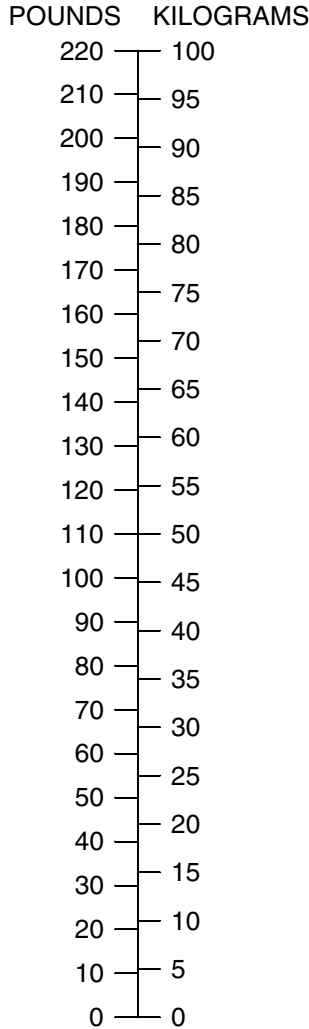

Units x 10, 100, etc

SR22\_FM09\_1510

**Figure - 1**  
**Sheet 2 of 2**

# Length Conversion

## Metres Into Feet Metres En Pieds

m	0	1	2	3	4	5	6	7	8	9
	ft	ft	ft	ft	ft	ft	ft	ft	ft	ft
0	0.0	3.3	6.6	9.8	13.1	16.4	19.7	23.0	26.3	29.5
10	32.8	36.1	39.4	42.7	45.9	49.2	52.5	55.8	59.1	62.3
20	65.6	68.9	72.2	75.5	78.7	82.0	85.3	88.6	91.9	95.1
30	98.4	101.7	105.0	108.3	111.6	114.8	118.1	121.4	124.7	128.0
40	131.2	134.5	137.8	141.1	144.4	147.6	150.9	154.2	157.5	160.8
50	164.0	167.3	170.6	173.4	177.2	180.5	183.7	187.0	190.3	193.6
60	196.9	200.1	203.4	206.7	210.0	213.3	216.5	219.8	223.1	226.4
70	229.7	232.9	236.2	239.5	242.8	246.1	249.3	252.6	255.9	259.2
80	262.5	265.8	269.0	272.3	275.6	278.9	282.2	285.4	288.7	292.0
90	295.3	298.6	301.8	305.1	308.4	311.7	315.0	318.2	321.5	324.8
100	328.1	331.4	334.6	337.9	341.2	344.5	347.8	351.0	354.3	357.6

## Feet Into Metres Pieds En Metres

Ft	0	1	2	3	4	5	6	7	8	9
	m	m	m	m	m	m	m	m	m	m
0	0.0	0.3	0.6	0.9	1.2	1.5	1.8	2.1	2.4	2.7
10	3.0	3.4	3.6	4.0	4.3	4.6	4.9	5.2	5.5	5.8
20	6.1	6.4	6.7	7.0	7.3	7.6	7.9	8.2	8.5	8.8
30	9.1	9.4	9.8	10.1	10.4	10.7	11.0	11.3	11.6	11.9
40	12.2	12.5	12.8	13.1	13.4	13.7	14.0	14.3	14.6	14.9
50	15.2	15.5	15.9	16.2	16.5	16.8	17.1	17.4	17.7	18.0
60	18.3	18.6	18.9	19.2	19.5	19.8	20.1	20.4	20.7	21.0
70	21.3	21.6	21.9	22.3	22.6	22.9	23.2	23.5	23.8	24.1
80	24.4	24.7	25.0	25.3	25.6	25.9	26.2	26.5	26.8	27.1
90	27.4	27.7	28.0	28.3	28.7	29.0	29.3	29.6	29.9	30.2
100	30.5	30.8	31.1	31.4	31.7	32.0	32.3	32.6	32.9	33.2

Figure - 2  
Sheet 1 of 4



# Length Conversion

Metres x 3.281 = Feet

Feet x 0.305 = Metres

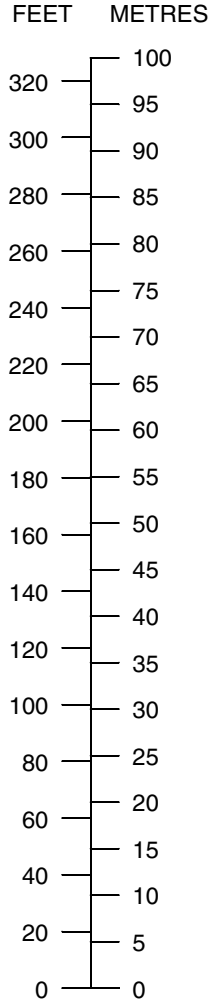

Units x 10, 100, etc

SR22\_FM09\_1511

**Figure - 2**  
**Sheet 2 of 4**

# Length Conversion

## Centimeters Into Inches Centimeters En Pouces

cm	0	1	2	3	4	5	6	7	8	9
	inch	inch	inch	inch	inch	inch	inch	inch	inch	inch
0	0.0	0.39	0.79	1.18	1.58	1.97	2.36	2.76	3.15	3.54
10	3.94	4.33	4.72	5.12	5.51	5.91	6.30	6.70	7.09	7.48
20	7.87	8.27	8.66	9.06	9.45	9.84	10.24	10.63	11.02	11.42
30	11.81	12.21	12.60	12.99	13.39	13.78	14.17	14.57	14.96	15.35
40	15.75	16.14	16.54	16.93	17.32	17.72	18.11	18.50	18.90	19.29
50	19.69	20.08	20.47	20.87	21.26	21.65	22.05	22.44	22.84	23.23
60	23.62	24.02	24.41	24.80	25.20	25.59	25.98	26.38	26.77	27.16
70	27.56	27.95	28.35	28.74	29.13	29.53	29.92	30.32	30.71	31.10
80	31.50	31.89	32.28	32.68	33.07	33.47	33.86	34.25	34.65	35.04
90	35.43	35.83	36.22	36.61	37.01	37.40	37.80	38.19	38.58	38.98
100	39.37	39.76	40.15	40.55	40.95	41.34	41.73	42.13	42.52	42.91

## Inches Into Centimeters Pouces En Centimetres

in.	0	1	2	3	4	5	6	7	8	9
	cm	cm	cm	cm	cm	cm	cm	cm	cm	cm
0	0.0	2.5	5.1	7.6	10.2	12.7	15.2	17.8	20.3	22.9
10	25.4	27.9	30.5	33.0	35.6	38.1	40.6	43.2	45.7	48.3
20	50.8	53.3	55.9	58.4	61.0	63.5	66.0	68.6	71.1	73.7
30	76.2	78.7	81.3	83.8	86.4	88.9	91.4	94.00	96.5	99.1
40	101.6	104.1	106.7	109.2	111.8	114.3	116.8	119.4	121.9	124.5
50	127.0	129.5	132.1	134.6	137.2	139.7	142.2	144.8	147.3	149.9
60	152.4	154.9	157.5	160.0	162.6	165.1	167.6	170.2	172.7	175.3
70	177.8	180.3	182.9	185.4	188.0	190.5	193.0	195.6	198.1	200.7
80	203.2	205.7	208.3	210.8	213.4	215.9	218.4	221.0	223.5	226.1
90	228.6	231.1	233.7	236.2	238.8	241.3	243.8	246.4	248.9	251.5
100	254.0	256.5	259.1	261.6	264.2	266.7	269.2	271.8	274.3	276.7

Figure - 2  
Sheet 3 of 4

# Length Conversion

Centimeters x 0.394 = Inches

Inches x 2.54 = Centimeters

INCHES    CENTIMETERS

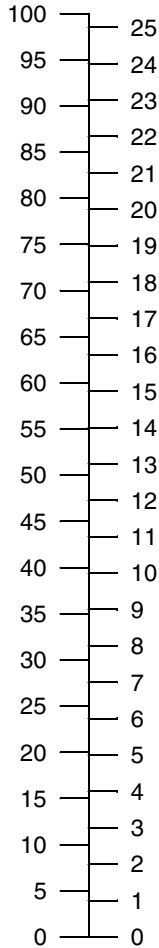

Units x 10, 100, etc

SR22\_FM09\_1989

**Figure - 2**  
**Sheet 4 of 4**

# Distance Conversion

Statute Miles x 1.609 = Kilometers  
 Statute Miles x 0.869 = Nautical Miles  
 Nautical Miles x 1.852 = Kilometers

Kilometers x 0.622 = Statute Miles  
 Nautical Miles x 1.15 = Statute Miles  
 Kilometers x 0.54 = Nautical Miles

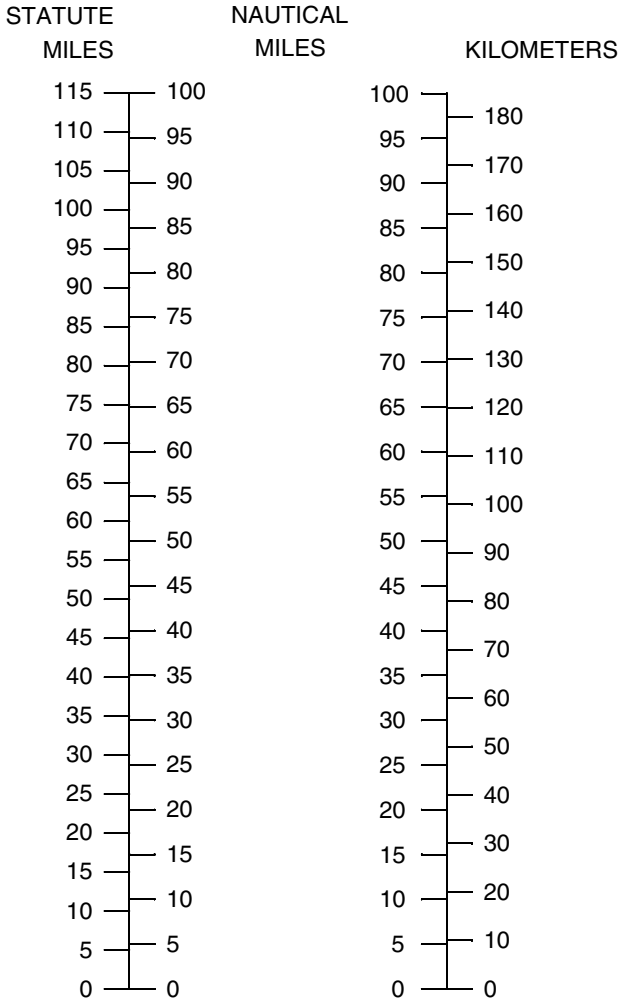

Units x 10, 100, etc

SR22\_FM09\_1990

**Figure - 3**

# Temperature Conversion

• Note •

- To convert from Celsius (°C) to Fahrenheit (°F), find, in the shaded columns, the number representing the temperature value (°C) to be converted. The equivalent Fahrenheit temperature is read to the right.  
→ **EXAMPLE:** 38° C = 100° F.
- To convert from Fahrenheit (°F) to Celsius (°C), find in the shaded columns area, the number representing the temperature value (°F) to be converted. The equivalent Celsius temperature is read to the left.  
→ **EXAMPLE:** 38° F = 3° C.

Temp to Convert °C or °F			Temp to Convert °C or °F			Temp to Convert °C or °F		
°C	↔	°F	°C	↔	°F	°C	↔	°F
-50	<b>-58</b>	-72	-17	<b>2</b>	36	17	<b>62</b>	144
-49	<b>-56</b>	-69	-16	<b>4</b>	39	18	<b>64</b>	147
-48	<b>-54</b>	-65	-14	<b>6</b>	43	19	<b>66</b>	151
-47	<b>-52</b>	-62	-13	<b>8</b>	46	20	<b>68</b>	154
-46	<b>-50</b>	-58	-12	<b>10</b>	50	21	<b>70</b>	158
-44	<b>-48</b>	-54	-11	<b>12</b>	54	22	<b>72</b>	162
-43	<b>-46</b>	-51	-10	<b>14</b>	57	23	<b>74</b>	165
-42	<b>-44</b>	-47	-9	<b>16</b>	61	24	<b>76</b>	169
-41	<b>-42</b>	-44	-8	<b>18</b>	64	26	<b>78</b>	172
-40	<b>-40</b>	-40	-7	<b>20</b>	68	27	<b>80</b>	176
-39	<b>-38</b>	-36	-6	<b>22</b>	72	28	<b>82</b>	180
-38	<b>-36</b>	-33	-4	<b>24</b>	75	29	<b>84</b>	183
-37	<b>-34</b>	-29	-3	<b>26</b>	79	30	<b>86</b>	187
-36	<b>-32</b>	-26	-2	<b>28</b>	82	31	<b>88</b>	190
-34	<b>-30</b>	-22	-1	<b>30</b>	86	32	<b>90</b>	194
-33	<b>-28</b>	-18	0	<b>32</b>	90	33	<b>92</b>	198
-32	<b>-26</b>	-15	1	<b>34</b>	93	34	<b>94</b>	201
-31	<b>-24</b>	-11	2	<b>36</b>	97	36	<b>96</b>	205
-30	<b>-22</b>	-8	3	<b>38</b>	100	37	<b>98</b>	208
-29	<b>-20</b>	-4	4	<b>40</b>	104	38	<b>100</b>	212
-28	<b>-18</b>	0	6	<b>42</b>	108	39	<b>102</b>	216
-27	<b>-16</b>	3	7	<b>44</b>	111	40	<b>104</b>	219
-26	<b>-14</b>	7	8	<b>46</b>	115	41	<b>106</b>	223
-24	<b>-12</b>	10	9	<b>48</b>	118	42	<b>108</b>	226
-23	<b>-10</b>	14	10	<b>50</b>	122	43	<b>110</b>	230
-22	<b>-8</b>	18	11	<b>52</b>	126	44	<b>112</b>	234
-21	<b>-6</b>	21	12	<b>54</b>	129	46	<b>114</b>	237
-20	<b>-4</b>	25	13	<b>56</b>	133	47	<b>116</b>	241
-19	<b>-2</b>	28	14	<b>58</b>	136	48	<b>118</b>	244
-18	<b>0</b>	32	16	<b>60</b>	140	49	<b>120</b>	248

Figure - 4

# Volume Conversion

## Litres Into Imperial Gallons Litres En Gallons Impérial

Lt	0	1	2	3	4	5	6	7	8	9
	Gal.	Gal.	Gal.	Gal.	Gal.	Gal.	Gal.	Gal.	Gal.	Gal.
0	0.0	0.22	0.44	0.66	0.88	1.10	1.32	1.54	1.76	1.98
10	2.20	2.42	2.64	2.86	3.08	3.30	3.52	3.74	3.96	4.18
20	4.40	4.62	4.84	5.06	5.28	5.50	5.72	5.94	6.16	6.38
30	6.60	6.82	7.04	7.26	7.48	7.70	7.92	8.14	8.36	8.58
40	8.80	9.02	9.24	9.46	9.68	9.90	10.12	10.34	10.56	10.78
50	11.00	11.22	11.44	11.66	11.88	12.10	12.32	12.54	12.76	12.98
60	13.20	13.42	13.64	13.86	14.08	14.30	14.52	14.74	14.96	15.18
70	15.40	15.62	15.84	16.06	16.28	16.50	16.72	16.94	17.16	17.38
80	17.60	17.82	18.04	18.26	18.48	18.70	18.92	19.14	19.36	19.58
90	19.80	20.02	20.24	20.46	20.68	20.90	21.12	21.34	21.56	21.78
100	22.00	22.22	22.44	22.66	22.88	23.10	23.32	23.54	23.76	23.98

## Imperial Gallons Into Litres Gallons Impérial En Litres

Gal.	0	1	2	3	4	5	6	7	8	9
	litres	litres	litres	litres	litres	litres	litres	litres	litres	litres
0	0.0	4.6	9.1	13.6	18.2	22.7	27.3	31.8	36.4	40.9
10	45.5	50.0	54.55	59.1	63.6	68.2	72.7	77.3	81.8	86.4
20	90.9	95.5	100.0	104.6	109.1	113.6	118.2	122.7	127.3	131.8
30	136.4	140.9	145.5	150.0	154.6	159.1	163.7	168.2	172.7	177.3
40	181.8	186.4	190.9	195.5	200.0	204.6	209.1	213.7	218.2	222.8
50	227.3	231.8	236.4	240.9	245.5	250.0	254.6	259.1	263.7	268.2
60	272.8	277.3	281.9	286.4	290.9	295.5	300.0	304.6	309.1	313.7
70	318.2	322.8	327.3	331.9	336.4	340.9	345.5	350.0	354.6	359.1
80	363.7	368.2	372.8	377.3	381.9	386.4	391.0	395.5	400.0	404.6
90	409.1	413.7	418.2	422.8	427.3	431.9	436.4	441.0	445.5	450.1
100	454.6	459.1	463.7	468.2	472.8	477.3	481.9	486.4	491.0	495.5

Figure - 5  
Sheet 1 of 2

# Volume Conversion

Imperial Gallons x 4.546 = Litres

Imperial Gallons x 1.2 = U.S. Gal.

U.S. Gallons x 3.785 = Litres

Litres x 0.22 = Imperial Gallons

U.S. Gal. x 0.833= Imperial Gallons

Litres x 0.264 = U.S. Gallons

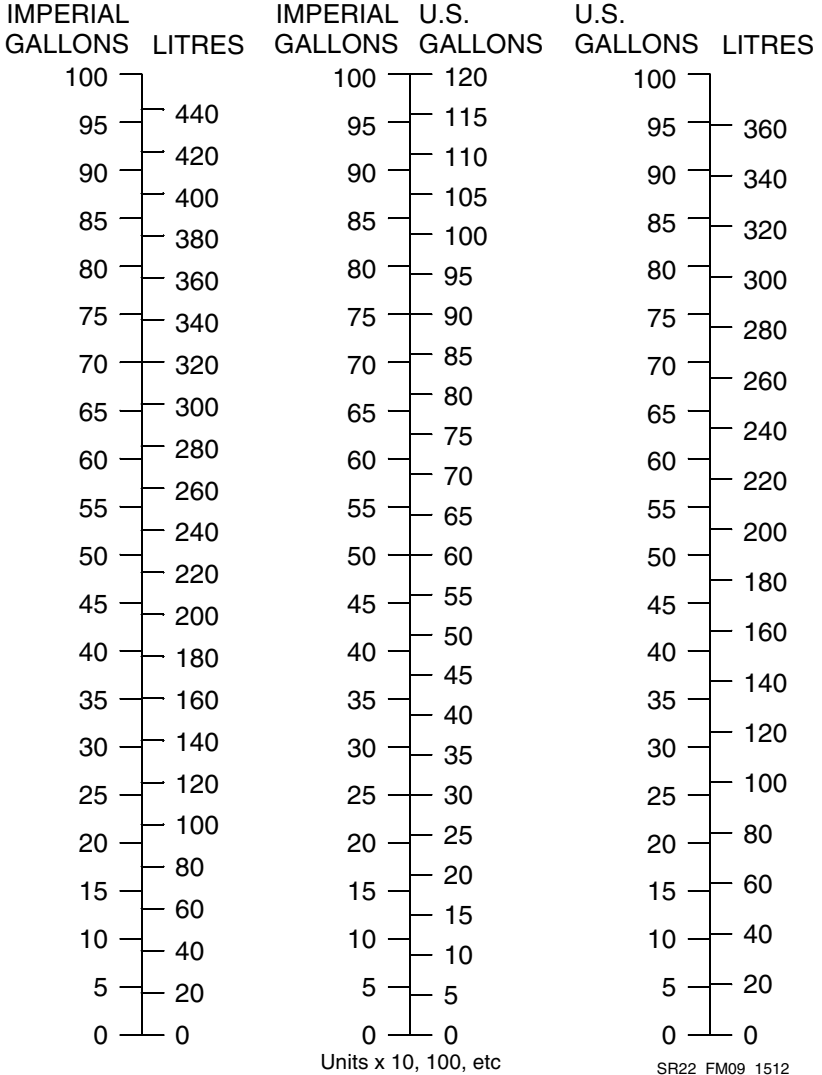

**Figure - 5**  
**Sheet 2 of 2**

# Volume to Weight Conversion

## AVGAS (Specific Gravity = 0.72)

Litres x 0.72 = Kilograms

Kilograms x 1.389 = Litres

Litres x 1.58 = Pounds

Pounds x 0.633 = Litres

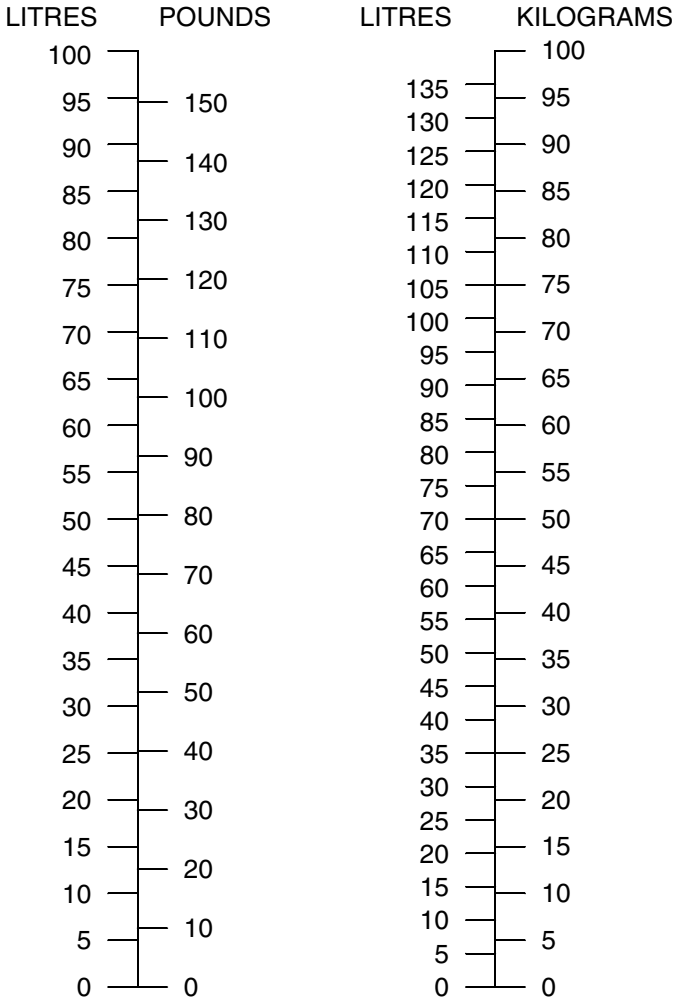

Units x 10, 100, etc

SR22\_FM09\_1513

Figure - 6



## Quick Conversions

In a world of U.S., Imperial, and metric measures, below is a quick way to convert from one system to another. Follow arrow and multiply; backtrack the arrow and divide. Bear in mind that the figures are approximations for quick reference but with enough accuracy to eliminate gross errors and dead-stick landings to abandoned airfields

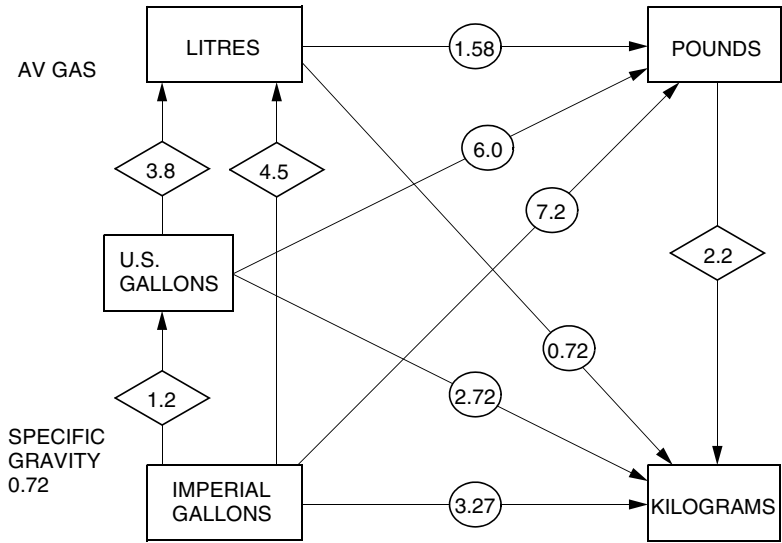

SR22\_FM09\_1514

Figure - 7

Intentionally Left Blank

**Pilot's Operating Handbook and  
FAA Approved Airplane Flight Manual  
Supplement  
for**

# **Ice Protection System**

When the Ice Protection System is installed on the Cirrus Design SR22, this POH Supplement is applicable and must be inserted in the Supplements Section (Section 9) of the Cirrus Design SR22 Pilot's Operating Handbook. This document must be carried in the airplane at all times. Information in this supplement adds to, supersedes, or deletes information in the basic SR22 Pilot's Operating Handbook.

• Note •

This POH Supplement Change, dated 01-30-05, supersedes and replaces revision 3 of this POH Supplement dated 07-03-04.

FAA Approved Joseph C. Mies Date Jan 30 2005  
for Royace H. Prather, Manager  
Chicago Aircraft Certification Office, ACE-115C  
Federal Aviation Administration

## Section 1 - General

The airplane is equipped with an Ice Protection System. This system allows a pilot who inadvertently enters icing conditions, to initiate de-icing fluid flow along the wing, horizontal stabilizer, and propeller blades.

## Section 2 - Limitations

1. Flight into known icing is prohibited.
2. De-icing fluids meeting DTD 406B:
  - AVL (DTD 406B) - Aviation Laboratories
  - AL-5 (DTD 406B) - Canyon Industries
  - Dimax 80 (TKS-80) - Canyon Industries
  - TKS-Fluid (DTD 406B) - D.W. Davies & Co

• Note •

The Ice Protection System is certified only as “No Hazard” to normal operations, therefore, no determination has been made as to the capability of this system to remove or prevent ice accumulation

## Placards

*LH Fuselage, above de-icing fluid filler cap:*

DE-ICING FLUID  
REFER TO AFM FOR APPROVED  
DE-ICING FLUIDS

## Section 3 - Emergency Procedures

### Inadvertent Icing Encounter

Flight into known icing conditions is prohibited. However, if icing is inadvertently encountered, determine the most appropriate operating mode:

NORMAL mode is selected when icing conditions are encountered and prior to ice accretion. Maximum system operating time is approximately 1 hour.

MAXIMUM mode is selected if ice has accreted to flight surfaces. Maximum system operating time is approximately 30 minutes.

#### • WARNING •

The Ice Protection System may not remove significant accumulations of ice if accretions are permitted to form with the Ice Protection System off.

Ensure system start time and system mode is noted while exiting icing conditions to aid in estimating de-icing fluid reserve.

1. Ice Protection Switch ..... As Required
2. Pitot Heat .....ON
3. Time .....NOTED
4. Exit icing conditions. Turn back and/or change altitude.
5. Cabin Heat .....MAXIMUM
6. Windshield Defrost..... FULL OPEN
7. Alternate Induction Air .....ON
8. When Icing Conditions Cleared, Ice Protection System .....OFF

## Section 4 - Normal Procedures

### Pre-Flight Inspection

1. Battery Master Switch ..... ON
2. Ice Protection Switch ..... MAXIMUM
3. Anti-Icing Fluid Quantity ..... Check Full
4. Fluid Vent (underside) ..... Unobstructed
5. Porous Panels ..... Condition and Security

• Note •

If allowed to run dry, the Metering Pump may fail to prime.  
*Refer to Section 8 for priming procedure.*

6. Porous Panels ..... Evidence of De-Icing Fluid
7. Slinger Ring ..... Evidence of De-Icing Fluid
8. Ice Protection Switch ..... OFF
9. Battery Master Switch ..... OFF

## Section 5 - Performance

Cruise speed is lower by approximately three knots and range is reduced by a maximum of 2%.

• Note •

Experience with your airplane's power settings may result in more accurate performance numbers than those given above.

1. Reduce KTAS shown on the Cruise Performance tables and the Range/Endurance Profile tables by 3 knots.
2. Reduce range shown on the Range/Endurance Profiles by 2%.

## Section 6 - Weight & Balance

Ice Protection System installation adds the optional (Sym = O) equipment at the weight, arm, and moment/1000 shown in the following figure.

ATA/Item	Description	Sym	Qty	Part Number	Unit Wt	Arm
30-01	Propeller Slinger Ring	O	1	15321-001	1.5	55.0
30-02	De-Icing Fluid Reservoir	O	1	15269-001	4.2	181.0
30-03	Metering Pump	O	1	15165-004	4.5	176.0

• Note •

De-icing fluid weight is 9.2 pounds per U.S gallon.

Weight LB	Moment/1000 Fluid Reservoir FS 181.0	Weight LB	Moment/1000 Fluid Reservoir FS 181.0
0.5	0.09	15.0	2.72
1.0	0.18	16.0	2.90
2.0	0.36	17.0	3.08
3.0	0.54	18.0	3.26
4.0	0.72	19.0	3.44
5.0	0.91	20.0	3.62
6.0	1.09	21.0	3.80
7.0	1.27	22.0	3.98
8.0	1.45	23.0	4.16
9.0	1.63	24.0	4.34
10.0	1.81	25.0	4.53
11.0	1.99	26.0	4.71
12.0	2.17	27.0	4.89
13.0	2.35	28.0*	5.07
14.0	2.53		

\*2.96 U.S. Gallons Capacity

**Figure - 1**  
**Equipment and Loading Data**

## Section 7 - System Description

### General

The Ice Protection System can prevent, and in certain conditions, remove ice accumulation on the flight surfaces by distributing a thin film of glycol-based fluid on the wing, horizontal stabilizer, and propeller. The presence of this fluid lowers the freezing temperature on the flight surface below that of the ambient precipitation preventing the formation and adhesion of ice.

The system consists of six porous panels, propeller slinger ring, four proportioning units, metering pump, filter, strainer, fluid tank, activation switch, filler cap, system plumbing, and attaching hardware. The system operates on 28 VDC supplied through the 5-amp ICE PROTECTION circuit breaker on Main Bus 1.

The de-icing fluid tank is serviced through a filler located on the LH side of the fuselage, just forward of the baggage door. The fluid tank, located behind the rear cabin trim panel, has a total capacity of 2.96 gallons. *Serials 0334 through 0434*; A three-position switch mounted on the center console panel controls system operation. *Serials 0435 and subsequent*; Two switches are mounted on the bolster panel. The first switch controls system operation through ON and OFF positions, the second switch controls system flow rate through MAXIMUM and NORMAL positions.

Upon activation, a two-speed metering pump, mounted below the LH passenger seat, supplies fluid pressure to the system. Low pump speed provides the required flow during NORMAL operation and high pump speed during MAXIMUM operation.

From the metering pump, de-icing fluid is pushed through a filter, mounted adjacent to the pump, and then carried to the proportioning units located in the wing, empennage, and cabin-floor forward through plastic tubing. Proportioning units regulate flow to the porous panels attached to the leading edges of the wing and horizontal stabilizer and to the propeller slinger ring.

De-icing fluid is carried from the proportioning units to the porous panels where the fluid is discharged at a low, steady flow rate through fine, laser-drilled holes.



De-icing fluid protects the propeller by a slinger ring mounted to the spinner backing plate where the fluid is distributed by centrifugal action onto grooved rubber boots fitted to the root end of the propeller blades.

## **Operation**

If icing is inadvertently encountered, the pilot switches the Ice Protection switch to NORMAL or MAXIMUM to initiate de-icing fluid flow along the protected surfaces. Pitot heat is turned ON and the time is noted to aid in estimating de-icing fluid reserve.

The pilot then maneuvers to exit the icing conditions, turns cabin heat to maximum, and windshield defrost and alternate induction air ON. Upon exiting the icing conditions, the system is turned OFF.

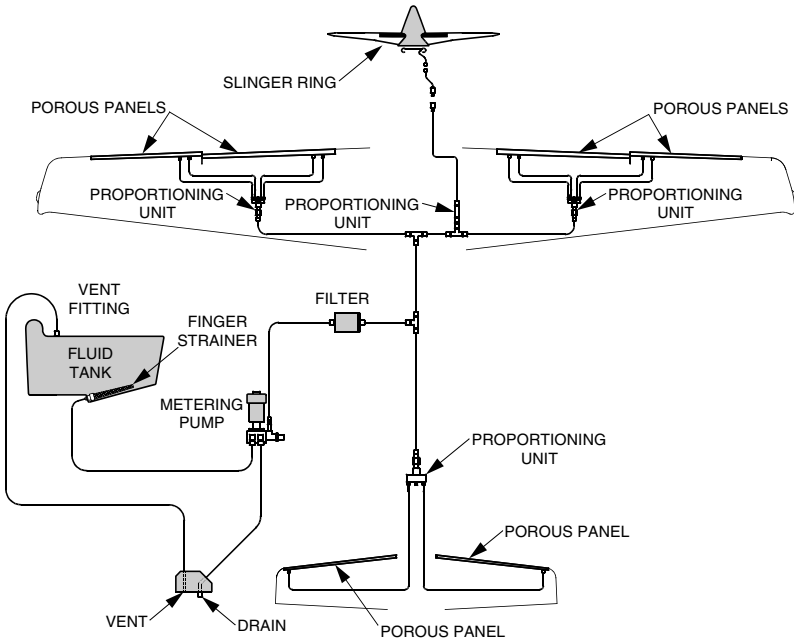

SR22\_FM09\_1527

**Figure - 2**  
**Ice Protection System**

## Section 8 – Handling, Service, & Maintenance

### Storage

• Note •

During long periods of non-use, the porous panel membranes may dry out which could cause uneven fluid flow during subsequent operation. Perform the Pre-Flight Inspection every 30 days to keep porous panel membranes wetted.

To prepare the Ice Protection System for flyable storage, fill the de-icing fluid tank and operate the system on MAXIMUM to ensure all air is completely purged from components and plumbing. Re-fill the de-icing fluid tank after purging.

### Servicing

#### *De-Icing Fluid Tank*

• Caution •

Use only approved de-icing fluid. See Section 2, Limitations

The de-icing fluid tank is serviced through a filler located on the LH side of the fuselage, just forward of the baggage door. To prevent de-icing fluid contamination, maintain a clean, dedicated measuring container and ensure mouth of fluid container is clean before dispensing. Secure the filler cap immediately after filling.

#### *Porous Panels*

• Caution •

Certain solvents may damage the panel membrane. Use only isopropyl alcohol, ethyl alcohol, or industrial methylated spirit to clean panels.

Do not wax leading edge porous panels.

Periodically clean the porous panels with soap and water using a clean, lint-free cloth. Isopropyl Alcohol may be used to remove oil or grease.

### *System Priming*

If allowed to run dry, the metering pump may fail to prime because of air trapped in the system. If no de-icing fluid is evident during the Pre-Flight Inspection, perform the following procedure:

1. Locate de-icing fluid drain on LH side of fuselage belly just forward of fluid tank.

**• Caution •**

Use a dedicated de-icing fluid sample cup for the following step.

Do not use the fuel sampling cup.

2. Sample de-icing fluid until fluid streams shows no evidence of air bubbles for at least three seconds.
3. Perform Pre-Flight Inspection verifying evidence of de-icing fluid from porous panels and slinger ring.
4. If necessary, repeat steps 2 and 3.

## Section 10 – Safety Information

The Ice Protection System is not intended to remove ice from the aircraft on the ground. Do not attempt to take off with frost, ice, or snow on flying surfaces.

Flight into known icing is prohibited. The Ice Protection System has not been evaluated in known icing conditions. Therefore, the affects of known icing on the system is unknown. Its purpose is to provide some protection from the effects of ice, should an unexpected encounter with icing conditions occur. At the first indication of icing, the most expeditious and safest course of exiting the icing conditions should be taken. The decision should be based on weather briefings, recent pilot reports, ATC observations, and may include course changes or altitude changes.

During simulated icing encounters, stall speed increases of approximately 12 knots in the clean configuration and 3 knots in the landing configuration were observed. In addition, cruise speed was reduced by at least 20 KCAS and the airplanes rate of climb diminished by at least 20%.

Even with the protected flight surfaces totally clear of ice, performance degradation will occur due to ice on unprotected regions. The amount of the degradation cannot be accurately predicted and it is therefore, depending on circumstances, advisable to increase approach and landing speeds while using the Ice Protection System. Use extreme caution during approach and landing, being alert to the first signs of pre-stall buffet and an impending stall.

Intentionally Left Blank

**Pilot's Operating Handbook and  
FAA Approved Airplane Flight Manual  
Supplement  
for**

# **Avidyne Entegra-Series Primary Flight Display**

**Software Version 530-00123-000 or 530-00159-000**

When the Avidyne FlightMax Entegra Primary Flight Display (PFD) with Software Version 530-00123-XXX or 530-00159-XXX (where X can be any digit from 0 to 9) is installed in the Cirrus Design SR22, this POH Supplement is applicable and must be inserted in the Supplements Section (Section 9) of the Cirrus Design SR22 Pilot's Operating Handbook. This document must be carried in the airplane at all times. Information in this supplement adds to, supersedes, or deletes information in the basic SR22 Pilot's Operating Handbook.

• Note •

This POH Supplement Change, dated 12-07-04 supersedes and replaces Revision 1 of this POH Supplement dated 07-03-04.

FAA Approved Joseph C. Miss Date Dec 07 2004  
for Royace H. Prather, Manager  
Chicago Aircraft Certification Office, ACE-115C  
Federal Aviation Administration

## Section 1 - General

The airplane is equipped with an Avidyne FlightMax Entegra-Series Primary Flight Display (PFD). The PFD is a 10.4" landscape-oriented display intended to be the primary display of primary flight parameter information (attitude, airspeed, heading, and altitude) to the pilot. The PFD accepts data from a variety of sources, including the GPS sensors, System 55X/System 55SR autopilots, and is the primary heading source for the EX5000 Multifunction Display.

The PFD replaces the following instruments:

- HSI
- Vertical Speed Indicator
- VOR/LOC Indicator
- Altitude Alerter
- OAT/Clock Indicator

Backup altimeter, airspeed, and attitude indicators are mounted on the bolster panel in case of total or partial PFD failure. To provide roll data to the autopilot system, a Turn Coordinator is mounted behind the RH bolster panel.

• Note •

The Avidyne system software version for this installation is 530-00123-XXX or 530-00159-XXX, where X can be any digit from 0 to 9.





Figure - 1  
Primary Flight Display

## Section 2 - Limitations

1. The PFD integrates with separately approved sensor installations. Adherence to limitations in appropriate installation POH supplements is mandatory.
2. The Avidyne FlightMax Entegra-Series PFD Pilot's Guide, P/N 600-00081-000, Revision 03, or latest revision, must be available to the pilot during all flight operations.
3. Flight under Instrument Flight Rules (IFR) is not permitted with the PFD or any standby indicator (attitude indicator or magnetic compass) inoperative. *Refer to Kinds of Operation Equipment List.*

• Note •

The Avidyne PFD software version is displayed on the PFD during system startup.

4. *Serials 0002 and subsequent before installation of PFD software version 530-00123-XXX-REV05 (where X can be any digit from 0 to 9):* Backcourse approaches are prohibited.

***When the PFD is coupled with Autopilot System, the following Limitations apply:***

5. Autopilot operation is prohibited above 185 KIAS.
6. The autopilot must not be engaged for takeoff or landing.
7. The autopilot must be disengaged for missed approach, go-around, and balked landing.
8. Flaps must be set to 50% for autopilot operation in Altitude Hold at airspeeds below 95 KIAS.
9. Flap deflection is limited to 50% during autopilot operations.
10. The autopilot must be disconnected in moderate or severe turbulence.
11. Minimum engage height for the autopilot is 400 ft AGL.

• **WARNING** •

Autopilot may not be able to maintain all selectable vertical speeds. Selecting a vertical speed that exceeds the aircraft's available performance may cause the aircraft to stall.

12. Minimum speed with the autopilot engaged is  $1.2V_S$  for the given configuration.

*For VOR/GPS and ILS glideslope and localizer intercept, capture, and tracking, the following limitations apply:*

- a. The autopilot must be disengaged no later than 100 feet below the Minimum Descent Altitude
- b. The autopilot must be disconnect during approach if course deviation exceeds 50%. The approach should only be continued by "hand-flying" the airplane.
- c. The autopilot must be disengaged at the Decision Height.
- d. 12 knot maximum crosswind component between the missed approach point and outer marker.
- e. The intercept of the localizer shall occur at least 5 miles outside of the outer marker.
- f. If the crosswind component is greater than 12 knots and less than 17 knots, the intercept shall occur at least 10 miles outside of the outer marker.
- g. The intercept angle shall be no greater than a 45-degree intercept.
- h. The ILS is flown at normal approach speeds, and within any STC or TC speed constraints and as defined in this flight manual.
- i. The flaps should be extended in the approach configuration prior to the Outer Marker. No further changes in the flap configuration should be made throughout the autopilot-coupled approach.
- j. The glideslope is approached in such a manner to allow automatic arming of the glideslope, or if the glideslope is manually armed no more than 15% above the glideslope.

## Kinds of Operation Equipment List

The following listing summarizes the equipment required under Federal Aviation Regulations (FAR) Part 23 for airworthiness under the listed kind of operation. Those minimum items of equipment necessary under the operating rules are defined in 14 CFR Part 91 and 14 CFR Part 135 as applicable.

• Note •

Flight operations conducted under IFR conditions is not permitted with the PFD or any standby indicator (attitude indicator or magnetic compass) inoperative.

System, Instrument, and/or Equipment	Kinds of Operation				Remarks, Notes, and/or Exceptions
	VFR Day	VFR Nt.	IFR Day	IFR Nt.	
<b>Navigation &amp; Pitot Static</b>					
PFD Attitude Indicator	-	-	1	1	
Backup Attitude Indicator	-	-	1	1	
PFD Airspeed Indicator	-	-	1	1	
Backup Airspeed Indicator	1	1	1	1	
PFD Altimeter	-	-	1	1	
Backup Altimeter	1	1	1	1	
PFD Heading	-	-	1	1	
Magnetic Compass	1	1	1	1	

## Section 3 - Emergency Procedures

• Note •

Dim brightness level to black if PFD is found distracting.

In the unlikely event of a PFD failure, the pilot may lose the ability to control the autopilot through the PFD controls. If this malfunction occurs, the PFD circuit breakers may be pulled and the airplane flown using the mechanical backup instruments. With the PFD circuit breakers pulled, autopilot lateral control is available in GPSS steering mode through GPS 1 and autopilot vertical control is available through the Vertical Speed (VS) and Altitude (ALT) modes on the autopilot head.

### Loss of Air Data

In the event the PFD detects a loss of air data, the affected indicator is removed from the display and replaced with a red "X". If loss of air data occurs, refer to the mechanical backup instruments (altitude, airspeed) and perform the following procedure:

1. Backup Instruments (altitude, airspeed) ..... MONITOR  
*If failure occurs while flying in IMC:*
2. Exit IMC.

## Loss of Attitude Data

### • WARNING •

*Aircraft equipped with Software Version 530-00123-000 Rev 00 or higher; Any power interruption to the PFD will result in loss of attitude information until the PFD can be restarted on the ground.*

*Aircraft equipped with Software Version 530-00159-000 Rev 00 or higher; When subjected to a power loss of less than 20 seconds, the PFD is capable of performing a warm start. In this event, a "PLEASE STANDBY" message will be displayed for 2 seconds followed by a "ATTEMPTING QUICK RESTART" message. In the event of a power loss greater than 20 seconds, a warm start is unlikely, and the power interruption will result in loss of attitude information until the PFD can be restarted on the ground.*

In the event the PFD detects a loss of attitude data, the affected indicator is removed from the display and replaced with a red "X". If loss of attitude data occurs, refer to the mechanical backup instruments (attitude, heading) and perform the following procedure:

1. Backup Instruments (attitude, heading) ..... MONITOR  
*If failure occurs while flying in IMC:*
2. Autopilot GPSS Mode ..... ACTIVATE
3. Autopilot Altitude Hold ..... ACTIVATE
4. Exit IMC.

## Section 4 - Normal Procedures

### Activate PFD

1. PFD Circuit Breakers ..... IN
2. Bat/Alt Master Switches .....ON

### De-Activate PFD

1. Bat/Alt Master Switches .....OFF  
*or*
2. PFD Circuit Breakers ..... PULL

## Section 5 - Performance

No Change.

## Section 6 - Weight & Balance

Installation of the Primary Flight Display adds the Required (Sym = C) equipment at the weight and arm shown in the following table:

ATA / Item	Description	Sym	Qty	Part Number	Unit Wt	Arm
34-01	Primary Flight Display	O	1	15222-001	12.0	115.5

## Section 7 - System Description

- Note •

This supplement provides a general description of the Avidyne FlightMax Entegra-Series Primary Flight Display, its operation, and airplane interface. For a detailed description of the PFD, *refer to the Avidyne FlightMax Entegra-Series PFD Pilot's Guide*, P/N 600-00081-000, Revision 03, or latest revision.

The Entegra PFD provides the functions of the attitude indicator, heading indicator, airspeed indicator, altimeter, vertical speed indicator, directional gyro, course deviation indicator, and altitude pre-select controller onto a single electronic display. In addition, the PFD communicates with GPS1, GPS2, NAV1, NAV2, the Multifunction Display, and Autopilot System.

An integral air data/attitude and heading reference system (ADAHRS) uses a 3-axis solid state gyro and accelerometer system combined with a magnetometer to replace the vertical and directional gyros. ADAHRS also provides roll, pitch, heading data and continually updates the winds aloft and true airspeed (TAS) indications on the PFD. The magnetometer assembly mounted in the wing also provides outside air temperature (OAT) data.

The airplane's Pitot-Static system is connected to the PFD to provide airspeed, altitude, and vertical speed.

Backup instruments for airspeed, attitude and altitude are mounted on the LH bolster panel and are on separate power sources than the PFD.

Redundant power sources provide 28 VDC for system operation. Power is supplied through the 10-amp PFD1 circuit breaker on the Essential Bus and the 10-amp PFD2 circuit breaker on Main Bus 2. Either circuit is capable of powering the PFD. System start-up is automatic once power is applied. The display presents the Initialization Display immediately after power is applied. Power-on default is 75% brightness. Typical alignment times are 3 minutes from battery turn on.



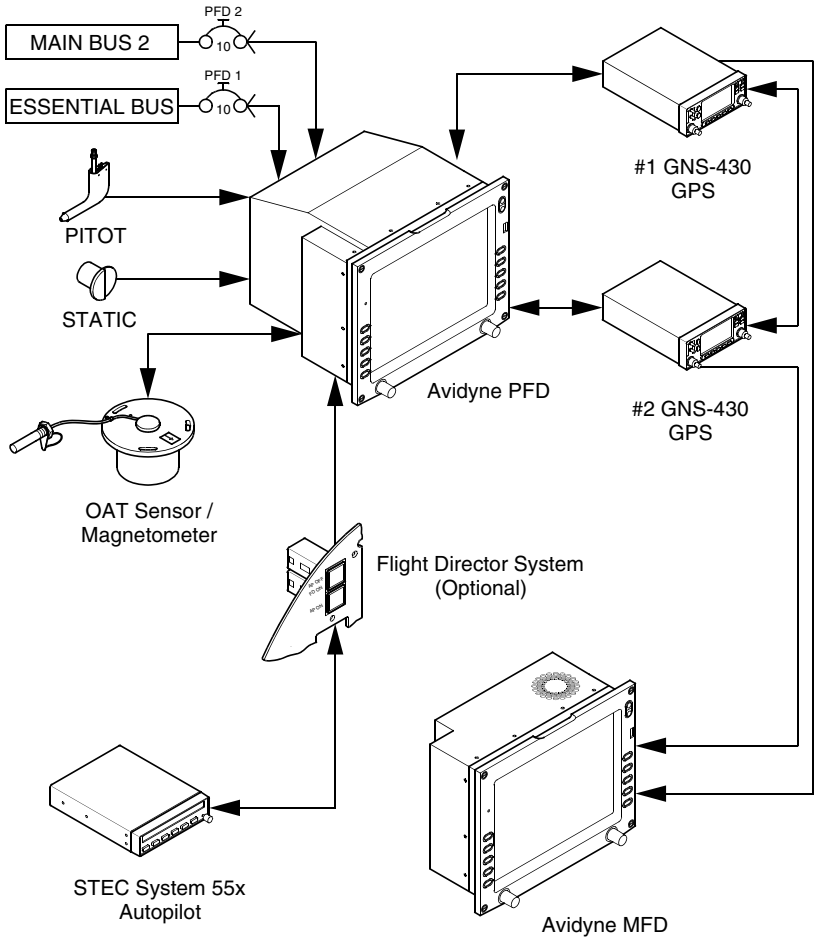

SR22\_FM09\_1607A

**Figure - 2**  
**Primary Flight Display System Schematic**

## Attitude Direction Indicator (ADI)

### *Air Data*

The airspeed tape to the left of the main ADI begins indicating at 20 Knots Indicated Airspeed (KIAS) and is color-coded to correspond with airspeeds for  $V_{SO}$ ,  $V_{FE}$ ,  $V_S$ ,  $V_{NO}$ , and  $V_{NE}$ . An altitude tape is provided to the right of the main ADI and also displays a symbol for the Altitude preselect (Altitude bug). The Vertical Speed Indicator (VSI) is displayed to the right of the altitude tape. The displayed scale of the VSI is +/- 2000 FPM and for rates above 2000 FPM, the needle will peg just outside the scale and a digital readout of actual VSI up to 4000 FPM is then displayed. An additional data block is provided for display of outside air temperature (OAT), true airspeed (TAS), and groundspeed (GS). Controls for selecting bug and barometric correction values are along the right side of the PFD. A wind indicator is also provided beneath the altitude tape.

### *Attitude Data*

Attitude is depicted on the main ADI using an aircraft reference symbol against a background of labeled pitch ladders and an arced scale along the top of the ADI to indicate bank angle. A skid/slip indicator is attached to the bottom edge of the bank angle pointer.

## Horizontal Situation Indicator (HSI)

### *Heading Data*

Magnetic heading is represented in boxed numeric form at the top of the compass rose. Heading rate (Rate of Turn Indicator) takes the form of a blue arcing arrow that begins behind the magnetic heading indicator and moves left or right accordingly. Graduations are provided on the rate-of-turn indicator scale to indicate half and full standard-rate turns. A heading bug is also provided on the compass rose.

## ***Navigation Data***

Navigation data on the PFD takes several forms. A course deviation indicator (CDI) is always provided on the HSI and a bearing pointer can be optionally selected for display on the HSI by the pilot. Controls for selecting the source of navigation data, selecting the display format of the navigation data, and for selecting the type of compass rose and moving map to be displayed are along the left side of the PFD. The active flight plan contained in the GPS Nav/Com unit selected as the primary navigation source (Nav) can be optionally selected for display on the HSI as well as the desired range of the optionally selectable moving map display. If a localizer or ILS frequency is tuned and captured in the GPS Nav/Com selected as the Nav source, a vertical deviation indicator (VDI) and horizontal deviation indicator (HDI) are automatically displayed on the ADI.

- Note •

In the event glide slope or localizer signals are lost, the HDI and/or VDI will be displayed as red-“X”s to indicate loss of signal. The red-“X”ed indicator will only be removed if the signal is regained, the Nav Source is changed on the PFD, or if the GPS Nav/Com is retuned to another frequency. Appropriate action must be taken by the pilot if on an approach.

## **Autopilot Integration**

The Entegra PFD is fully integrated with the System 55X and System 55SR autopilots. Heading, Altitude and VSI (55X only) reference bugs are provided to aid in autopilot control and pilot situational awareness. When in an active autopilot mode, full guidance is provided, including smooth transitions to altitude and heading captures. If not in an active autopilot mode (i.e., “hand-flying”), there is no guidance other than the position of the appropriate bugs, as set by the pilot

The reference bugs' status, autopilot annunciations, and flight director steering command bars (if installed) will indicate when Entegra is coupled with the autopilot. A solid magenta Heading, Altitude, or VSI (55X only) bug indicates that the function is currently coupled to an active mode of the autopilot. A hollow magenta bug indicates that the function is not currently coupled to the autopilot in an active mode. In other words, a hollow bug indicates manual or “hand-flying” status.

In flight director equipped aircraft, when a vertical mode of the autopilot is being used, a set of flight director command bars will indicate the required steering of the aircraft to achieve the commanded tracking from the autopilot. In autopilot mode, “AP” will be in the autopilot annunciation field, the command bars will be visible and magenta and the aircraft should track the bars.

In flight director only mode, “FD” will be displayed in the autopilot annunciation field, the command bars will be visible and green, and the pilot is expected to actuate the flight controls as required to track the bars.

The following six modes of the System 55X are supported by the Entegra PFD:

- ALT (Altitude Hold) Mode
- VS (Vertical Speed) Mode
- Altitude Capture Mode
- HDG (Heading Capture/Hold Mode)
- NAV Mode
- GPSS (GPS Steering) Mode

The following three modes of the System 55SR are supported by the Entegra PFD:

- ALT (Altitude Hold) Mode
- HDG (Heading Capture/Hold Mode)
- NAV Mode

• Note •

One of the horizontal modes (HDG, NAV, GPSS) must be engaged on the autopilot control interface before a vertical mode can be used.

When HDG mode is engaged, rotation of the heading bug greater than 180 degrees may result in a reversal of turn direction.

## Flight Director System (Optional Installation)

• Note •

For a detailed description of the Flight Director system, refer to *Avidyne FlightMax Entegra-Series PFD Pilot's Guide, P/N 600-00081-000, Revision 08, or later revision.*

The Flight Director system enhances situational awareness by reducing cockpit workload through providing a visual cue for the pilot to follow as indicated by the PFD's Flight Director Steering Command Bar. Through turning or pitching the airplane as "directed" by the Steering Command Bar, the pilot will follow the necessary course to arrive at a programmed destination.

Fully integrated with the S-Tec System 55X Autopilot, the Flight Director system replaces the "flying W" aircraft reference symbol on the PFD with the Flight Director Steering Command Bars and Wedge.

The system consists of two lighted push-buttons installed on the upper, LH side of the instrument panel and associated relays and wiring between the PFD and autopilot. The remaining portion of the Flight Director system is entirely software dependant.

The Flight Director system is powered by 28 VDC through the 5-amp AUTOPILOT circuit breaker on the Essential Bus. The following describes push-button annunciation and related Autopilot and Flight Director status:

No Annunciation	<ul style="list-style-type: none"><li>• Autopilot off. <i>or</i></li><li>• Autopilot not active in either roll or pitch control.</li></ul>
Green <b>AP ON</b> Annunciation	<ul style="list-style-type: none"><li>• Autopilot active in roll and/or pitch control.</li><li>• If Autopilot active in roll and pitch control, "AP" annunciation appears on top edge of PFD, and Flight Director Steering Command Bars MAGENTA.</li></ul>
Amber <b>AP OFF</b> <b>FD ON</b> Annunciation	<ul style="list-style-type: none"><li>• Autopilot uncoupled.</li><li>• If Autopilot active in roll and pitch control, Flight Director ON, "FD" annunciation appears on top edge of PFD, and Flight Director Steering Command Bars GREEN.</li></ul>

Intentionally Left Blank

**Pilot's Operating Handbook and  
FAA Approved Airplane Flight Manual  
Supplement**

# Winterization Kit

When the Winterization Kit Inlet covers are installed in accordance with SB 2X-71-04 R3, Cirrus Design drawing 70027, or Cirrus Design drawing 70102, this POH Supplement is applicable and must be inserted in the Supplements Section (Section 9) of the Cirrus Design SR22 Pilot's Operating Handbook. This document must be carried in the airplane at all times. Information in this supplement adds to, supersedes, or deletes information in the basic SR22 Pilot's Operating Handbook.

• Note •

This POH Supplement Revision dated 12-07-04 supersedes and replaces the Original Issue of this supplement dated 10-10-03.

FAA Approved Joseph C. Mies Date Dec 07 2004  
for Royace H. Prather, Manager  
Chicago Aircraft Certification Office, ACE-115C  
Federal Aviation Administration

## **Section 1 - General**

This airplane is equipped with removable cowl inlet airflow restrictors. Figure 1 shows installation instructions.

## **Section 2 - Limitations**

### **Winterization Kit**

1. The airplane must not be operated above 32°F when the Winterization Kit cowl inlet covers (airflow restrictors) are installed.

### **Placards**

***On forward side of each Cowl Inlet Cover:***

**REMOVE WHEN  
OUTSIDE TEMP  
IS ABOVE 32° F**

***On aft side of each Cowl Inlet Cover:***

***Serials 0002 through 0794 and Serials 0796 through 0819:***

**NOT FOR USE ON A/C  
W/ LANDING LIGHT  
IN COWL INLET**

## **Section 3 - Emergency Procedures**

No Change.



## **Section 4 - Normal Procedures**

### **Install Cowl Inlet Airflow Restrictor (See Figure 1)**

1. Loosen screw securing latch plate to inlet cover and slide latch plate inboard.
2. Position inlet cover in inlet.
3. Slide latch plate outward (behind edge of cowl) and tighten screw.
4. Install inboard screw securing inlet cover to cowl.
5. Repeat procedure for opposite cowl inlet cover.

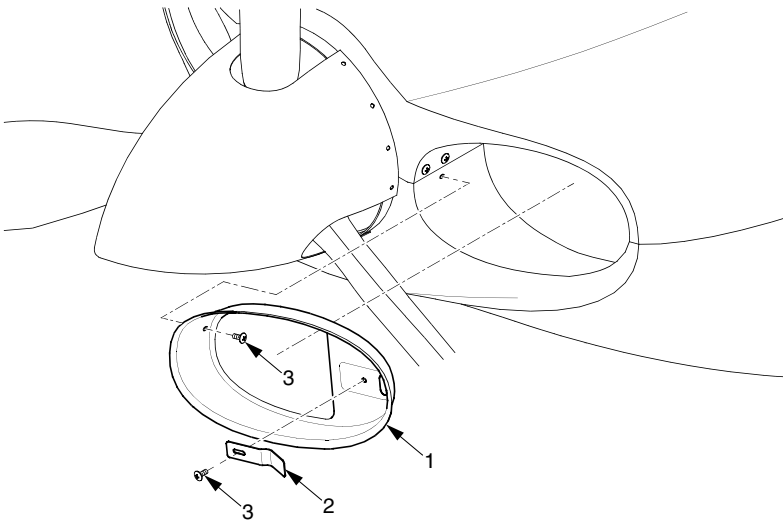

*Serials 0002 through 0794 and 0796 through 0819.*

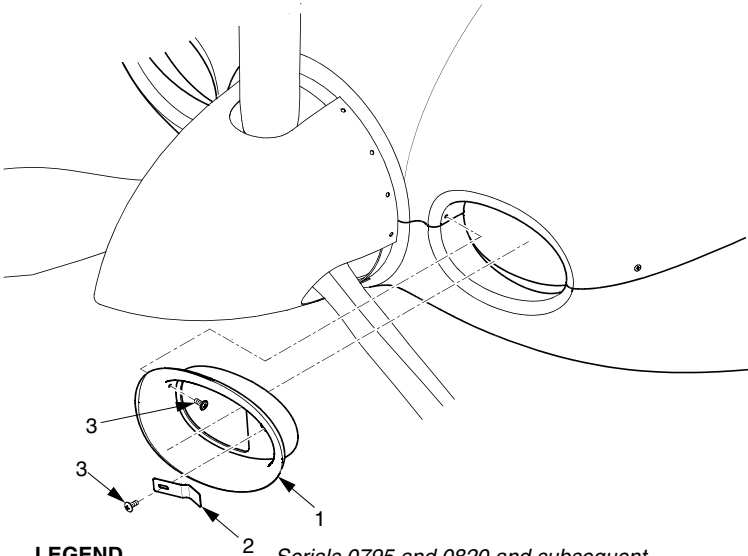

*Serials 0795 and 0820 and subsequent.*

**LEGEND**

- 1. Cowl Inlet Cover
- 2. Latch Plate
- 3. Screw

SR22\_FM09\_1516A

**Figure - 1**  
**Cowl Inlet Installation**

## Section 5 - Performance

No Change.

## Section 6 - Weight & Balance

Change is Negligible.

## Section 7 - Systems Description

### • Caution •

Use of the inlet cover airflow restrictors above 32° F (0° C) ambient temperature may result in CHT and Oil Temperatures above the red line.

The Winterization Kit consists of two cowl inlet covers that can be easily installed in the inlets to restrict airflow into the engine compartment. When the ambient temperature is below 32° F (0° C), installing the inlet covers allows the engine to reach and maintain CHT (Cylinder Head Temperatures) and Oil Temperatures well into the green arc. The covers are easily installed and removed using only a screwdriver.

Intentionally Left Blank

**Pilot's Operating Handbook and  
FAA Approved Airplane Flight Manual  
Supplement  
for  
Cirrus Design SR22 Airplanes Registered in  
Israel**

1. This supplement is required for operation of Cirrus Design SR22 airplanes when registered in Israel. This supplement must be attached to the applicable SR22 FAA-approved Airplane Flight Manual (P/N 13772-001 Reissue A dated 10-10-03 or later FAA-approved Flight Manual revision).
2. The information contained within this supplement is to be used in conjunction with the basic AFM and supplements. The information contained herein supplements or supersedes that in the basic manual and approved supplements only in those areas indicated.
3. Compliance with the limitations contained in the basic manual and approved supplements is mandatory.
4. Foreign operating rules and any references to such rules in the basic manual and approved supplements are not applicable in Israel. The aircraft must be equipped and operated in accordance with Israeli operating requirements. *Refer to the Civil Aviation Administration of Israel (CAAI) Air Navigation Regulations (Operation of Aircraft and Rules of Flight)*, for the operating rules and equipment requirements that do pertain to operations in Israel.
5. The Kinds of Operating Equipment List (KOEL) may not necessarily apply in Israel. Refer to CAAI operating rules.

FAA Approved \_\_\_\_\_ Date Dec 03 2003  
On behalf of Joseph C. Miss  
CAA Israel for Royace H. Prather, Manager  
Chicago Aircraft Certification Office, ACE-115C  
Federal Aviation Administration

# Weight Conversion

## Kilograms Into Pounds

kg	0	1	2	3	4	5	6	7	8	9
	lb.	lb.	lb.	lb.	lb.	lb.	lb.	lb.	lb.	lb.
0	0.0	2.2	4.4	6.6	8.8	11.0	13.2	15.4	17.6	19.8
10	22.0	24.3	26.5	28.7	30.9	33.1	35.3	37.5	39.6	41.9
20	44.1	46.3	48.5	50.7	52.9	55.1	57.3	59.5	61.7	63.9
30	66.1	68.3	70.5	72.8	75.0	77.2	79.4	81.6	83.8	86.0
40	88.2	90.4	92.6	94.8	97.0	99.2	101.4	103.6	105.8	108.0
50	110.2	112.4	114.6	116.9	119.0	121.3	123.5	125.7	127.9	130.0
60	132.3	134.5	136.7	138.9	141.1	143.3	145.5	147.7	149.9	152.1
70	154.3	156.5	158.7	160.9	163.1	165.4	167.6	169.8	172.0	174.1
80	176.4	178.6	180.8	183.0	185.2	187.4	189.6	191.8	194.0	196.2
90	198.4	200.6	202.8	205.0	207.2	209.4	211.6	213.9	216.0	218.3
100	220.5	222.7	224.9	227.1	229.3	231.5	233.7	235.9	238.1	240.3

## Pounds Into Kilograms

lb.	0	1	2	3	4	5	6	7	8	9
	kg	kg	kg	kg	kg	kg	kg	kg	kg	kg
0	0.0	0.5	0.9	1.4	1.8	2.3	2.7	3.2	3.6	4.1
10	4.5	5.0	5.4	5.9	6.4	6.8	7.3	7.7	8.2	8.6
20	9.1	9.5	10.0	10.4	10.9	11.3	11.8	12.2	12.7	13.2
30	13.6	14.1	14.5	15.0	15.4	15.9	16.3	16.8	17.2	17.7
40	18.1	18.6	19.1	19.5	20.0	20.4	20.9	21.3	21.8	22.2
50	22.7	23.1	23.6	24.0	24.5	24.9	25.4	25.9	26.3	26.8
60	27.2	27.7	28.1	28.6	29.0	29.5	29.9	30.4	30.8	31.3
70	31.8	32.2	32.7	33.1	33.6	34.0	34.5	34.9	35.4	35.8
80	36.8	36.7	37.2	37.6	38.1	38.6	39.0	39.5	39.9	40.4
90	40.8	41.3	41.7	42.2	42.6	43.1	43.5	44.0	44.5	44.9
100	45.4	45.8	46.3	46.7	47.2	47.6	48.1	48.5	49.0	49.4

Figure - 1  
Sheet 1 of 2

# Weight Conversion

Kilograms x 2.205 = Pounds

Pounds x 0.454 = Kilograms

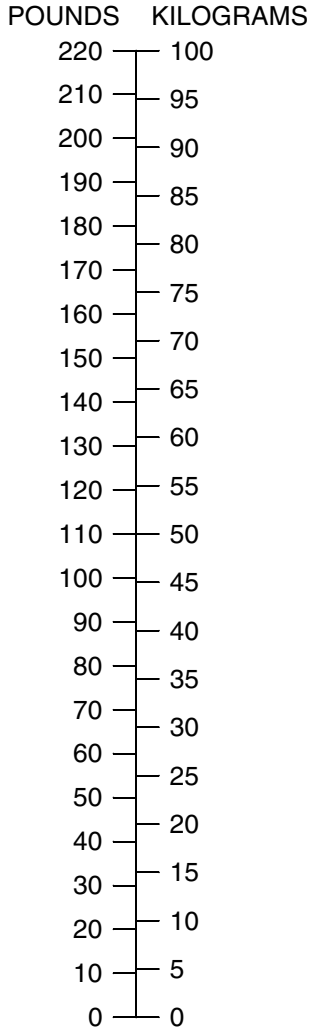

Units x 10, 100, etc

SR22\_FM09\_1510

**Figure - 1**  
**Sheet 2 of 2**

# Length Conversion

## Meters Into Feet

m	0	1	2	3	4	5	6	7	8	9
	ft	ft	ft	ft	ft	ft	ft	ft	ft	ft
0	0.0	3.3	6.6	9.8	13.1	16.4	19.7	23.0	26.3	29.5
10	32.8	36.1	39.4	42.7	45.9	49.2	52.5	55.8	59.1	62.3
20	65.6	68.9	72.2	75.5	78.7	82.0	85.3	88.6	91.9	95.1
30	98.4	101.7	105.0	108.3	111.6	114.8	118.1	121.4	124.7	128.0
40	131.2	134.5	137.8	141.1	144.4	147.6	150.9	154.2	157.5	160.8
50	164.0	167.3	170.6	173.4	177.2	180.5	183.7	187.0	190.3	193.6
60	196.9	200.1	203.4	206.7	210.0	213.3	216.5	219.8	223.1	226.4
70	229.7	232.9	236.2	239.5	242.8	246.1	249.3	252.6	255.9	259.2
80	262.5	265.8	269.0	272.3	275.6	278.9	282.2	285.4	288.7	292.0
90	295.3	298.6	301.8	305.1	308.4	311.7	315.0	318.2	321.5	324.8
100	328.1	331.4	334.6	337.9	341.2	344.5	347.8	351.0	354.3	357.6

## Feet Into Meters

Ft	0	1	2	3	4	5	6	7	8	9
	m	m	m	m	m	m	m	m	m	m
0	0.0	0.3	0.6	0.9	1.2	1.5	1.8	2.1	2.4	2.7
10	3.0	3.4	3.6	4.0	4.3	4.6	4.9	5.2	5.5	5.8
20	6.1	6.4	6.7	7.0	7.3	7.6	7.9	8.2	8.5	8.8
30	9.1	9.4	9.8	10.1	10.4	10.7	11.0	11.3	11.6	11.9
40	12.2	12.5	12.8	13.1	13.4	13.7	14.0	14.3	14.6	14.9
50	15.2	15.5	15.9	16.2	16.5	16.8	17.1	17.4	17.7	18.0
60	18.3	18.6	18.9	19.2	19.5	19.8	20.1	20.4	20.7	21.0
70	21.3	21.6	21.9	22.3	22.6	22.9	23.2	23.5	23.8	24.1
80	24.4	24.7	25.0	25.3	25.6	25.9	26.2	26.5	26.8	27.1
90	27.4	27.7	28.0	28.3	28.7	29.0	29.3	29.6	29.9	30.2
100	30.5	30.8	31.1	31.4	31.7	32.0	32.3	32.6	32.9	33.2

Figure - 2  
Sheet 1 of 4



# Length Conversion

Meters x 3.281 = Feet

Feet x 0.305 = Meters

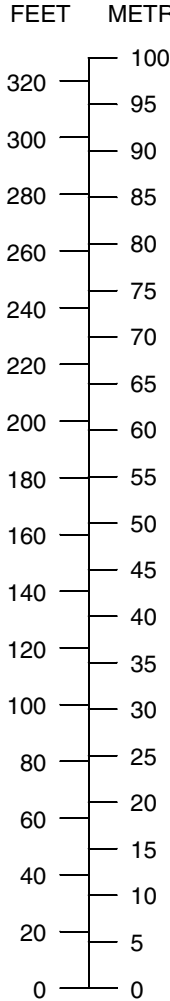

Units x 10, 100, etc

SR22\_FM09\_1511

**Figure - 2**  
**Sheet 2 of 4**

# Length Conversion

## Centimeters Into Inches

cm	0	1	2	3	4	5	6	7	8	9
	inch	inch	inch	inch	inch	inch	inch	inch	inch	inch
0	0.0	0.39	0.79	1.18	1.58	1.97	2.36	2.76	3.15	3.54
10	3.94	4.33	4.72	5.12	5.51	5.91	6.30	6.70	7.09	7.48
20	7.87	8.27	8.66	9.06	9.45	9.84	10.24	10.63	11.02	11.42
30	11.81	12.21	12.60	12.99	13.39	13.78	14.17	14.57	14.96	15.35
40	15.75	16.14	16.54	16.93	17.32	17.72	18.11	18.50	18.90	19.29
50	19.69	20.08	20.47	20.87	21.26	21.65	22.05	22.44	22.84	23.23
60	23.62	24.02	24.41	24.80	25.20	25.59	25.98	26.38	26.77	27.16
70	27.56	27.95	28.35	28.74	29.13	29.53	29.92	30.32	30.71	31.10
80	31.50	31.89	32.28	32.68	33.07	33.47	33.86	34.25	34.65	35.04
90	35.43	35.83	36.22	36.61	37.01	37.40	37.80	38.19	38.58	38.98
100	39.37	39.76	40.15	40.55	40.95	41.34	41.73	42.13	42.52	42.91

## Inches Into Centimeters

in.	0	1	2	3	4	5	6	7	8	9
	cm	cm	cm	cm	cm	cm	cm	cm	cm	cm
0	0.0	2.5	5.1	7.6	10.2	12.7	15.2	17.8	20.3	22.9
10	25.4	27.9	30.5	33.0	35.6	38.1	40.6	43.2	45.7	48.3
20	50.8	53.3	55.9	58.4	61.0	63.5	66.0	68.6	71.1	73.7
30	76.2	78.7	81.3	83.8	86.4	88.9	91.4	94.00	96.5	99.1
40	101.6	104.1	106.7	109.2	111.8	114.3	116.8	119.4	121.9	124.5
50	127.0	129.5	132.1	134.6	137.2	139.7	142.2	144.8	147.3	149.9
60	152.4	154.9	157.5	160.0	162.6	165.1	167.6	170.2	172.7	175.3
70	177.8	180.3	182.9	185.4	188.0	190.5	193.0	195.6	198.1	200.7
80	203.2	205.7	208.3	210.8	213.4	215.9	218.4	221.0	223.5	226.1
90	228.6	231.1	233.7	236.2	238.8	241.3	243.8	246.4	248.9	251.5
100	254.0	256.5	259.1	261.6	264.2	266.7	269.2	271.8	274.3	276.7

Figure - 2  
Sheet 3 of 4

# Length Conversion

Centimeters x 0.394 = Inches

Inches x 2.54 = Centimeters

INCHES    CENTIMETERS

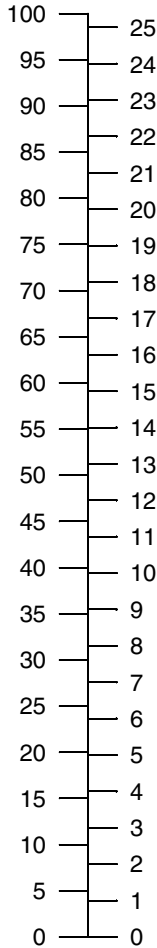

Units x 10, 100, etc

SR22\_FM09\_1989

**Figure - 2**  
**Sheet 4 of 4**

# Distance Conversion

Statute Miles x 1.609 = Kilometers  
 Statute Miles x 0.869 = Nautical Miles  
 Nautical Miles x 1.852 = Kilometers

Kilometers x 0.622 = Statute Miles  
 Nautical Miles x 1.15 = Statute Miles  
 Kilometers x 0.54 = Nautical Miles

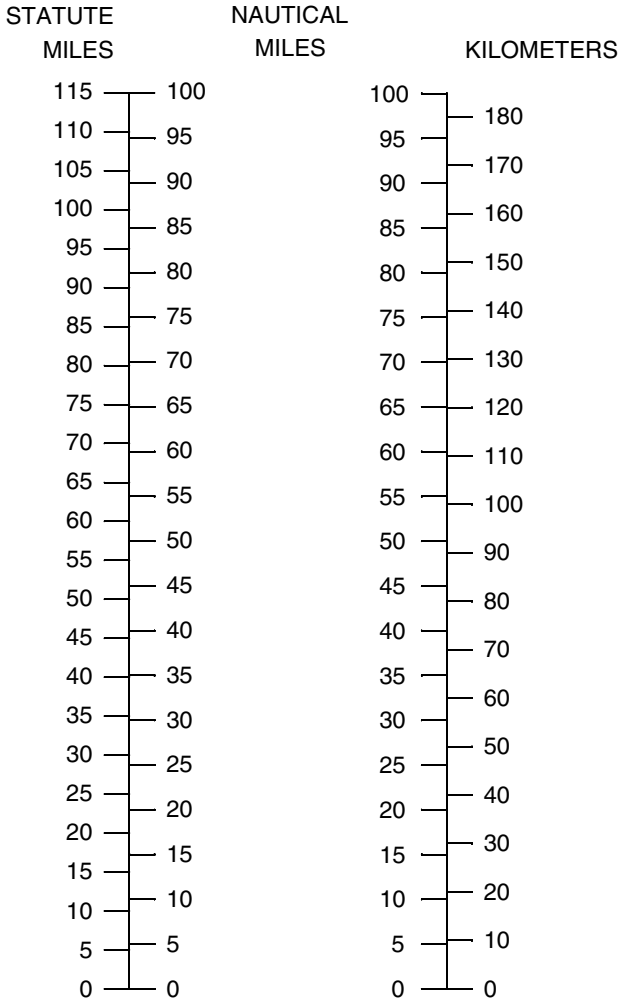

Units x 10, 100, etc

SR22\_FM09\_1990

Figure - 3

# Temperature Conversion

• Note •

- To convert from Celsius (°C) to Fahrenheit (°F), find, in the shaded columns, the number representing the temperature value (°C) to be converted. The equivalent Fahrenheit temperature is read to the right.  
→ **EXAMPLE:** 38° C = 100° F.
- To convert from Fahrenheit (°F) to Celsius (°C), find in the shaded columns area, the number representing the temperature value (°F) to be converted. The equivalent Celsius temperature is read to the left.  
→ **EXAMPLE:** 38° F = 3° C.

Temp to Convert °C or °F			Temp to Convert °C or °F			Temp to Convert °C or °F		
°C	↔	°F	°C	↔	°F	°C	↔	°F
-50	<b>-58</b>	-72	-17	<b>2</b>	36	17	<b>62</b>	144
-49	<b>-56</b>	-69	-16	<b>4</b>	39	18	<b>64</b>	147
-48	<b>-54</b>	-65	-14	<b>6</b>	43	19	<b>66</b>	151
-47	<b>-52</b>	-62	-13	<b>8</b>	46	20	<b>68</b>	154
-46	<b>-50</b>	-58	-12	<b>10</b>	50	21	<b>70</b>	158
-44	<b>-48</b>	-54	-11	<b>12</b>	54	22	<b>72</b>	162
-43	<b>-46</b>	-51	-10	<b>14</b>	57	23	<b>74</b>	165
-42	<b>-44</b>	-47	-9	<b>16</b>	61	24	<b>76</b>	169
-41	<b>-42</b>	-44	-8	<b>18</b>	64	26	<b>78</b>	172
-40	<b>-40</b>	-40	-7	<b>20</b>	68	27	<b>80</b>	176
-39	<b>-38</b>	-36	-6	<b>22</b>	72	28	<b>82</b>	180
-38	<b>-36</b>	-33	-4	<b>24</b>	75	29	<b>84</b>	183
-37	<b>-34</b>	-29	-3	<b>26</b>	79	30	<b>86</b>	187
-36	<b>-32</b>	-26	-2	<b>28</b>	82	31	<b>88</b>	190
-34	<b>-30</b>	-22	-1	<b>30</b>	86	32	<b>90</b>	194
-33	<b>-28</b>	-18	0	<b>32</b>	90	33	<b>92</b>	198
-32	<b>-26</b>	-15	1	<b>34</b>	93	34	<b>94</b>	201
-31	<b>-24</b>	-11	2	<b>36</b>	97	36	<b>96</b>	205
-30	<b>-22</b>	-8	3	<b>38</b>	100	37	<b>98</b>	208
-29	<b>-20</b>	-4	4	<b>40</b>	104	38	<b>100</b>	212
-28	<b>-18</b>	0	6	<b>42</b>	108	39	<b>102</b>	216
-27	<b>-16</b>	3	7	<b>44</b>	111	40	<b>104</b>	219
-26	<b>-14</b>	7	8	<b>46</b>	115	41	<b>106</b>	223
-24	<b>-12</b>	10	9	<b>48</b>	118	42	<b>108</b>	226
-23	<b>-10</b>	14	10	<b>50</b>	122	43	<b>110</b>	230
-22	<b>-8</b>	18	11	<b>52</b>	126	44	<b>112</b>	234
-21	<b>-6</b>	21	12	<b>54</b>	129	46	<b>114</b>	237
-20	<b>-4</b>	25	13	<b>56</b>	133	47	<b>116</b>	241
-19	<b>-2</b>	28	14	<b>58</b>	136	48	<b>118</b>	244
-18	<b>0</b>	32	16	<b>60</b>	140	49	<b>120</b>	248

Figure - 4

# Volume Conversion

## Liters Into U.S Gallons

Lt	0	1	2	3	4	5	6	7	8	9
	Gal.	Gal.	Gal.	Gal.	Gal.	Gal.	Gal.	Gal.	Gal.	Gal.
0	0.0	0.3	0.5	0.8	1.1	1.3	1.6	1.8	2.1	2.4
10	2.6	2.9	3.2	3.4	3.7	4.0	4.2	4.5	4.8	5.0
20	5.3	5.5	5.8	6.1	6.3	6.6	6.9	7.1	7.4	7.7
30	7.9	8.2	8.5	8.7	9.0	9.2	9.5	9.8	10.0	10.3
40	10.6	10.8	11.1	11.4	11.6	11.9	12.2	12.4	12.7	12.9
50	13.2	13.5	13.7	14.0	14.3	14.5	14.8	15.1	15.3	15.6
60	15.9	16.1	16.4	16.6	16.9	17.2	17.4	17.7	18.0	18.2
70	18.5	18.8	19.0	19.3	19.5	19.8	20.1	20.3	20.6	20.9
80	21.1	21.4	21.7	21.9	22.2	22.5	22.7	23.0	23.2	23.5
90	23.8	24.0	24.3	24.6	24.8	25.1	25.4	25.6	25.9	26.2
100	26.4	26.7	26.9	27.2	27.5	27.7	28.0	28.3	28.5	28.8

## U.S Gallons Into Liters

Gal.	0	1	2	3	4	5	6	7	8	9
	Liters	Liters	Liters	Liters	Liters	Liters	Liters	Liters	Liters	Liters
0	0.0	3.8	7.6	11.4	15.1	18.9	22.7	26.5	30.3	34.1
10	37.9	41.6	45.4	49.2	53.0	56.8	60.6	64.4	68.1	71.9
20	75.7	79.5	83.3	87.1	90.8	94.6	98.4	102.2	106.0	109.8
30	113.6	117.3	121.1	124.9	128.7	132.5	136.3	140.1	143.8	147.6
40	151.4	155.2	159.0	162.8	166.6	170.3	174.1	177.9	181.7	185.5
50	189.3	193.1	196.8	200.6	204.4	208.2	212.0	215.8	219.6	223.3
60	227.1	230.9	234.7	238.5	242.3	246.1	249.8	253.6	257.4	261.2
70	265.0	268.8	272.5	276.3	280.1	283.9	287.7	291.5	295.3	299.0
80	302.8	306.6	310.4	314.2	318.0	321.8	325.5	329.3	333.1	336.9
90	340.7	344.5	348.3	352.0	355.8	359.6	363.4	367.2	371.0	374.8
100	378.5	382.3	386.1	389.9	393.7	397.5	401.3	405.0	408.8	412.6

Figure - 5  
Sheet 1 of 2

# Volume Conversion

U.S. Gallons x 3.785 = Liters

Liters x 0.264 = U.S. Gallons

IMPERIAL  
GALLONS    LITRES

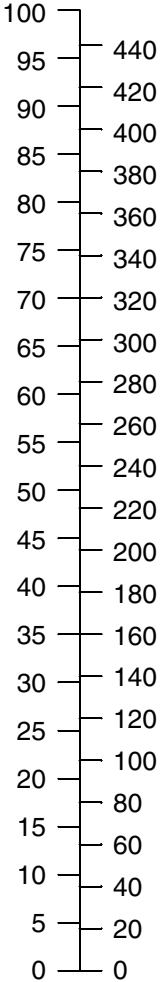

IMPERIAL U.S.  
GALLONS    GALLONS

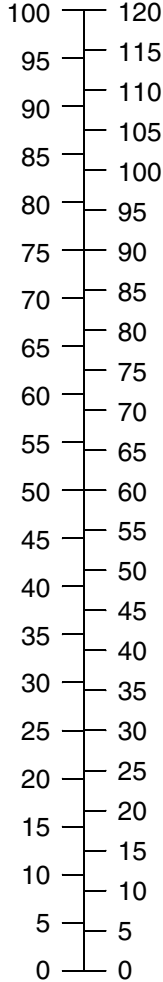

Units x 10, 100, etc

U.S.  
GALLONS    LITRES

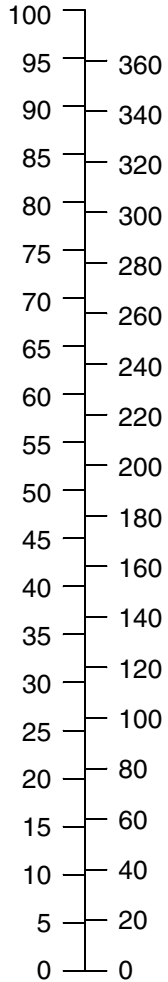

SR22\_FM09\_1512

**Figure - 5**  
**Sheet 2 of 2**

# Volume to Weight Conversion

## AVGAS (Specific Gravity = 0.72)

Liters x 0.72 = Kilograms

Kilograms x 1.389 = Liters

Liters x 1.58 = Pounds

Pounds x 0.633 = Liters

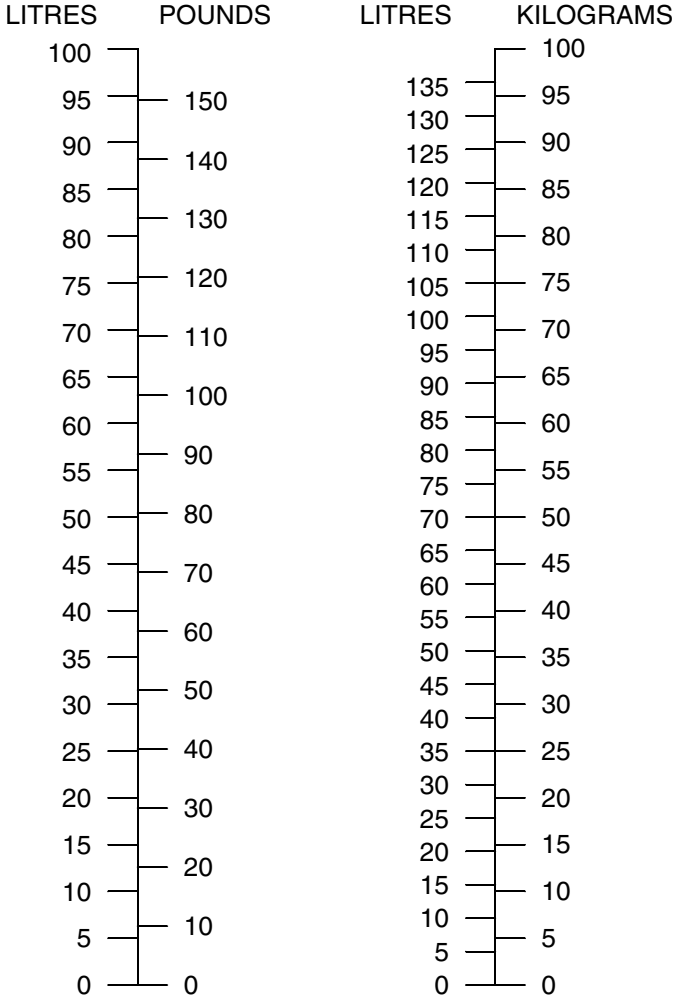

Units x 10, 100, etc

SR22\_FM09\_1513

Figure - 6



## Quick Conversions

In a world of U.S., Imperial, and metric measures, below is a quick way to convert from one system to another. Follow arrow and multiply; backtrack the arrow and divide. Bear in mind that the figures are approximations for quick reference but with enough accuracy to eliminate gross errors and dead-stick landings to abandoned airfields

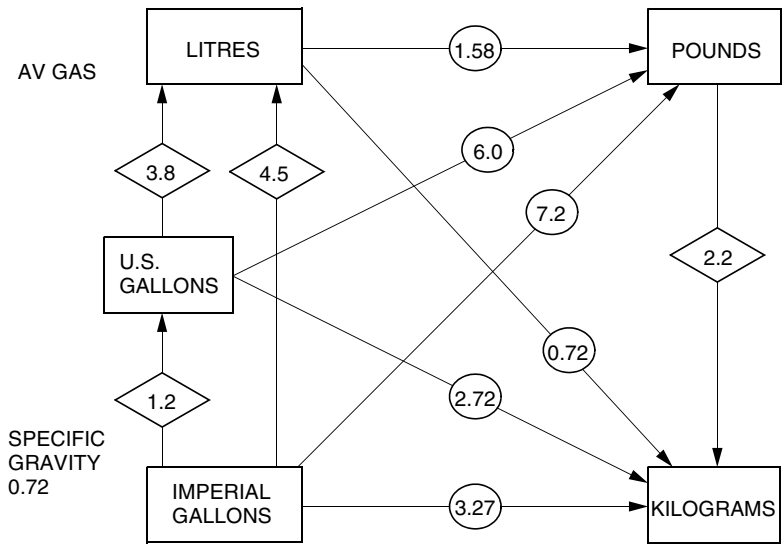

SR22\_FM09\_1514

Figure - 7

Intentionally Left Blank

**Pilot's Operating Handbook and  
FAA Approved Airplane Flight Manual  
Supplement  
for**

**Garmin GTX 330 Mode S  
Transponder**

When a Garmin GTX 330 Transponder is installed in the Cirrus Design SR22, this Supplement is applicable and must be inserted in the Supplements Section (Section 9) of the Cirrus Design SR22 Pilot's Operating Handbook. This document must be carried in the airplane at all times. Information in this supplement adds to, supersedes, or deletes information in the basic SR22 Pilot's Operating Handbook.

FAA Approved Joseph C. Miss Date July 03 2004  
for Royace H. Prather, Manager  
Chicago Aircraft Certification Office, ACE-115C  
Federal Aviation Administration

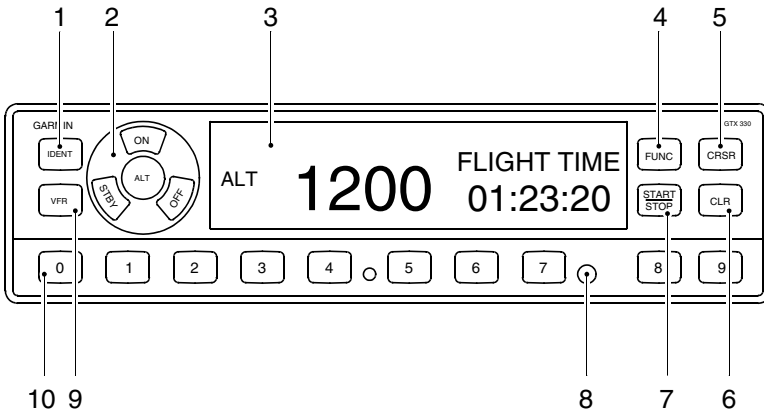

- |                        |                                      |
|------------------------|--------------------------------------|
| 1. Identification Key  | 5. CRSR (Cursor)                     |
| 2. Mode Selector Keys  | 6. CLR (Clear) Key                   |
| a. OFF                 | 7. START/STOP Key                    |
| b. STBY (Standby)      | 8. Photocell                         |
| c. ON                  | 9. VFR Key                           |
| d. ALT                 | 10. Selector Keys                    |
| 3. Display Window      | a. 0-7 - Code Selection              |
| 4. FUNC (Function) Key | b. 8-9 - Display Brightness/Contrast |

SR22\_FM09\_1965

**Figure - 1**  
**Garmin GTX 330 Transponder**

## Section 1 - General

The airplane is equipped with a single Garmin GTX 330 ATC Mode S transponder with IDENT capability. This supplement provides complete operating instructions for the GTX 330 and does not require any additional data be carried in the airplane.

## Section 2 - Limitations

No Change

## Section 3 - Emergency Procedures

No Change.

## Section 4 - Normal Procedures

- Note •

Expected coverage from the GTX 330 is limited to “line of sight.” Low altitude or aircraft antenna shielding by the airplane itself may result in reduced range. Range can be improved by climbing to a higher altitude.

### After Engine Start

1. Avionics Power Switch .....ON

The transponder will turn on in the same mode of operation selected at the last power down and will display the last entered identification code.

### Before Takeoff

1. Transponder Mode Selector Keys .....ALT

If the transponder is in STBY or GND mode, it will automatically switch to ALT during takeoff when the groundspeed increases through approximately 35 knots. The transponder will respond to ATC Mode A/C (altitude and identification) interrogations.

- Note •

Selecting ON puts the transponder in Mode A/S only. The transponder will respond to Mode C (altitude) interrogations with signals that contain no altitude information.

## After Landing

1. Transponder Mode Selector Keys ..... STBY or OFF

If the transponder is in the ALT or ON mode for landing, and the airplane is in a Mode S environment, the transponder will automatically switch to GND during landing rollout when the groundspeed decreases through approximately 35 knots. If the airplane is not in a Mode S environment, the transponder will automatically switch to STBY during landing rollout.

## Section 5 - Performance

No Change.

## Section 6 - Weight & Balance

No Change.

## Section 7 - Systems Description

• Note •

This supplement provides specific procedures for use of the GTX 330 Transponder in the SR22 and a general description of the unit. For a detailed description of the GTX 330, *refer to GARMIN GTX 330 Mode S Transponder Pilots Guide, p/n 190-00207-00 Revision A (Sept 2002) or later revision.*

The Garmin GTX 330 transponder system consists of an integrated receiver/transmitter control unit, an antenna, and an altitude digitizer. In addition to displaying the code, reply symbol, and mode of operation, the GTX 330 displays pressure altitude. The unit also features an altitude monitor and flight timers. Depending on how the transponder is configured (factory set to voice), a voice or tone audio output announces altitude deviation of more than 200 feet and count down timer expiration.

• Caution •

The transponder's configuration, including the unique Mode S aircraft address, is set at time of installation. Use caution when modifying the configuration. Do not enter the Configuration Mode during flight.

While providing the usual identification code and pressure altitude information as Mode A and C transponders, the Mode S transponder also uses a unique aircraft address to enhance the tracking capabilities of ATC and other Mode S transponder-equipped aircraft. The interrogations that ground-based surveillance radar transmit include the identification information of the target airplane ensuring that when other aircraft receive the interrogation, they will not respond.

Digitized altitude information is provided by the altitude digitizer (encoder) plumbed into the airplane static system. The transponder and integrated controls are mounted in the center console. The transponder control provides active code display, code selection, IDENT button, and test functions. The display is daylight readable and is automatically dimmed through a photocell. The controller buttons are dimmed through the INST lights control on the instrument panel bolster. The transponder antenna is mounted on the underside of the fuselage just aft of the firewall. 28 VDC for transponder operation is controlled through the Avionics Master Switch on the bolster switch panel. 28 VDC for receiver, transmitter, and altitude encoder operation is supplied through the 2-amp ENCODER/XPONDER circuit breaker on the Avionics Non-Essential.

## Reply Light

The reply light is the small reverse video “R” immediately below the mode annunciation in the display window. The reply light will blink each time the transponder replies to ground interrogations. The light will remain on during the 18-second IDENT time interval.

## Mode Selector Keys

The mode selector keys are located in a circular arrangement immediately to the left of the display window. The selected mode is annunciated at the left side of the display immediately adjacent to the selector keys. The four positions are:

**OFF** - Turns off all power to the GTX 330 transponder. The transponder should be off until the engine is started. Normally, the transponder can be left in the STBY position and allow the Avionics Power Switch to control system power.

**STBY** - Powers the transponder in standby mode. The last active identification code will be selected. In STBY, the transponder will not

reply to any interrogations from an ATC secondary ground surveillance radar system. This is the normal position for ground operations in the SR22.

• Note •

Depend on the ATC environment, STBY or GND mode is automatically entered from ALT or ON mode during landing ground roll as the groundspeed decreases through 35 knots.

**ON** - Powers on the GTX 330 in Mode A (identification mode.). The last active identification code will be selected. In addition to the airplane's identification code, the transponder will also reply to altitude (Mode C) interrogations with signals that do not contain altitude information.

**ALT** - Places the transponder in Mode A and Mode C, identification and altitude respectively. The last active identification code will be selected. The transponder will respond to interrogations with the unique aircraft address and standard pressure altitude (29.92 inches Hg).

• Note •

ALT mode is automatically entered from STBY mode during takeoff ground roll as the groundspeed increases through 35 knots.

## Code Selector Keys

Code selection is accomplished by depressing the eight selector keys (numbered 0 - 7) located immediately below the display. Any of 4096 active identification codes can be selected. The selected code must be in accordance with instructions for IFR flight or rules applicable to transponder utilization for VFR flight.

The airplane's transponder code is used to enhance tracking capability by ATC. Therefore, do not switch the transponder to STBY when making routine code changes.

### ***Input a New Code***

1. Use "0 - 7" keys to input the new code. The new code will not be activated until the last (fourth) digit is entered. Pressing the CLR key will move the cursor back to the previous digit. Pressing the



CRSR key during code entry will remove the cursor and cancel the entry.

• Note •

When making routine code changes, avoid inadvertent selection of code 7500 and all codes within the 7600 series (7600 – 7677) and 7700 series (7700 – 7777). These codes trigger special indicators in automated facilities. 7500 will be decoded as the hijack code.

**Important Codes**

- 1200 – VFR code for any altitude in U.S.
- 7000 – VFR code commonly used in Europe
- 7500 – Hijacking
- 7600 – Loss of communications
- 7700 – Emergency
- 7777 – Military interceptor operations (Never squawk this code)
- 0000 – Military use only (Not enterable)

**Function Keys**

**IDENT Key**

Pressing the IDENT button activates the Special Position Identification (SPI) pulse for approximately 18 seconds allowing ATC to identify your transponder return from other returns on the controller's scope. The Reply annunciator in the display will illuminate during the SPI pulse. Momentarily press the IDENT key when the controller requests, "SQUAWK IDENT."

**VFR Key**

Pressing the VFR key sets the transponder to the pre-programmed VFR code selected in the Configuration Mode (factory set to 1200). Pressing the VFR key a second time will restore the previous identification code.

**FUNC Key**

Pressing the FUNC key changes the data shown on the right side of the display. Pressing the FUNC key a second time will cycle the display to the next data. Displayed data includes Pressure Altitude,

Flight Time, Count Up Timer, Count Down Timer, Contrast, and Display Brightness.

**START/STOP Key** - Starts and stops the Altitude Monitor, Count Up, Count Down, and Flight timers. In Configuration Mode, steps through functions in reverse.

**CRSR Key** - Initiates starting time entry for the Count Down timer. Returns cursor to last code digit within five seconds after entry. Selects changeable fields in Configuration Mode.

**CLRL Key** - Resets the Count Up, Count Down, and Flight timers. Cancels the previous keypress during code selection and Count Down entry. Returns cursor to the fourth code digit within five seconds after entry.

## Function Display

**PRESSURE ALT** - Displays pressure altitude in feet. An arrow to the right of the altitude indicates that the airplane is climbing or descending.

**FLIGHT TIME** - Displays the flight time. The timer receives groundspeed from GPS1. Flight time starts when the groundspeed reaches 35 knots on takeoff and pauses when the groundspeed descends below 35 knots on landing.

**ALT MONITOR** - Controlled by START / STOP key. Activates a voice alarm when altitude limit is exceeded

**COUNT UP TIMER** - The count up timer is controlled by the START / STOP key. Pressing the CLR key zeros the display.

**COUNT DOWN TIMER** - The count down timer is controlled by the START / STOP key. The CRSR and "0 - 9" keys are used to set the initial time. Pressing the CLR key resets the timer to the initial value.

**CONTRAST** - Allows adjustment of display contrast in Configuration Mode. When CONTRAST is selected, pressing the "8" key reduces contrast and pressing "9" increases contrast.

**DISPLAY** - The display function is not available in this installation. Display brightness is automatically controlled through a photocell in the front panel.

**Pilot's Operating Handbook and  
FAA Approved Airplane Flight Manual  
Supplement  
for**

**Honeywell KGP 560 Terrain  
Awareness/Warning System**

When the Honeywell KGP 560 Terrain Awareness and Warning System is installed in the Cirrus Design SR22, this Supplement is applicable and must be inserted in the Supplements Section (Section 9) of the Cirrus Design SR22 Pilot's Operating Handbook. This document must be carried in the airplane at all times. Information in this supplement adds to, supersedes, or deletes information in the basic SR22 Pilot's Operating Handbook.

FAA Approved Joseph C. Miss Date July 03 2004  
for Royace H. Prather, Manager  
Chicago Aircraft Certification Office, ACE-115C  
Federal Aviation Administration

## Section 1 - General

The airplane is equipped with an Honeywell KGP 560 Terrain Awareness and Warning System that performs the functions of a Class C Terrain Awareness and Warning System (TAWS) in accordance with TSO C151b.

Incorporating much of the technology found in TAWS for air transport aircraft, the KGP 560 supports:

- Alerting for premature descent.
- Alerting for excessive rate of climb/descent.
- Altitude callout (500 ft) and alerting within 5 nm of 2000 ft public runways.
- Look-ahead algorithms and integrated terrain/obstacle database.

The system consists of the 560 GA-EGPWS Processor mounted on the underside of the pilot-side kickplate, a Terrain/Obstacle Database integral to the processor, the Configuration Module integral to the system's wire harness, and the TAWS annunciator panel mounted on the lower LH portion of the instrument panel.

The KGP 560 receives data from the GPS sensor, Transponder, Primary Flight Display, and the Multifunction Display (MFD). Aural alerts are communicated to the pilot via the GMA 340 Audio Panel. To enhance the situational awareness to the pilot, color-coded terrain display is interfaced on the MFD.

For specific MFD operational details, *refer to the Cirrus Design Pilot's Operating Handbook and FAA Approved Airplane Flight Manual Supplement For Avidyne EX-Series Multifunction Flight Display, P/N 13772-112, Revision 01 or later.*

For specific KGP 560 operational details, *refer to the KGP 560 & 860 EGPWS Pilot's Guide, P/N 006-18254-001, Revision 4 or later.*

## Section 2 - Limitations

1. Do not use the Terrain Awareness Display for navigation of the aircraft. The KGP 560 Terrain Awareness and Warning System is intended to serve as a situational awareness tool only and may not provide the accuracy fidelity on which to solely base terrain or obstacle avoidance maneuvering decisions.

## Section 3 - Emergency Procedures

### Off-Airport Landings

1. For ditching or other off-airport landings, inhibit the Terrain Awareness System functions by selecting the TERR INHIBIT switch on the annunciator panel to prevent unwanted aural alerting.

## Section 4 - Normal Procedures

• Note •

Only vertical maneuvers are recommended responses to warnings and alerts unless operating in VMC or the pilot determines, using all available information and instruments, that a turn, in addition to the vertical escape maneuver, is the safest course of action.

During certain operations, warning thresholds may be exceeded due to specific terrain or operating procedures. During day VFR flight, these warnings may be considered as a cautionary.

If the TAWS issues an alert when the Terrain Awareness Display Page is not selected, a pop up message will appear on the active display page of the MFD. To clear the alert, the pilot must acknowledge the pop up message by pressing the Soft Key next to the displayed "OK".

Pilots are authorized to deviate from their current air traffic control (ATC) clearance to the extent necessary to comply with a TAWS warning.

## Activate TAWS

• Note •

If the aircraft horizontal position derived from the Garmin Navigator (GPS 1) is invalid, TAWS will be inoperative and the TERR INOP annunciator will illuminate.

1. SKYWATCH/TAWS Circuit Breaker..... IN
2. MFD Circuit Breaker..... IN
3. Battery Master Switch ..... ON
4. Avionics Power Switch ..... ON
5. Verify TERR INOP Annunciator .....OFF
6. At MFD prompt, any Key .....PRESS
7. MFD Soft Keys ..... SET to TAWS

## Response To Ground Proximity Warnings

### ***Aural “PULL UP” Warning***

### ***Red TERR WARN Annunciation***

1. Level the wings, simultaneously adding full power.
2. Increase pitch attitude to 15 degrees nose up.
3. Adjust pitch attitude to ensure terrain clearance while respecting stall warning. If flaps are extended, retract flaps to the UP position.
4. Continue climb at best angle of climb speed ( $V_X$ ) until terrain clearance is assured.

### ***Aural “SINK RATE” Warning***

### ***Aural “DON’T SINK” Warning***

### ***Amber TERR CAUT Annunciation***

1. Initiate appropriate corrective action to remove the cause of the warning.

## Response To Awareness Alerts

***Aural “TERRAIN AHEAD” Alert***

***Aural “OBSTACLE AHEAD” Alert***

***Amber TERR CAUT Annunciation***

1. Take positive corrective action until the alert ceases. Stop descending, or initiate a climb turn as necessary, based on analysis of all available instruments and information.

***Aural “TERRAIN AHEAD; PULL UP” Alert***

***Aural “OBSTACLE AHEAD; PULL UP” Alert***

***Red TERR WARN Annunciation***

1. Level the wings, simultaneously adding full power.
2. Increase pitch attitude to 15 degrees nose up.
3. Adjust pitch attitude to ensure terrain clearance while respecting stall warning. If flaps are extended, retract flaps to the UP position.
4. Continue climb at best angle of climb speed ( $V_x$ ) until terrain clearance is assured.

## Deactivate TAWS

1. SKYWATCH/TAWS Circuit Breaker..... PULL  
or
2. Avionics Power Switch ..... OFF

## Section 5 - Performance

No Change.

## Section 6 - Weight & Balance

Installation of the Honeywell KGP 560 Terrain Awareness and Warning System adds the following optional (Sym = O) equipment at the weight and arm shown in the following table.

ATA / Item	Description	Sym	Qty	Part Number	Unit Wt	Arm
34-01	KGP 560 Processor	O	1	15963-001	1.25	117.0

## Section 7 - Systems Description

The Honeywell KGP 560 Terrain Awareness and Warning System compares GPS information from the Garmin Navigator (GPS 1) to the integrated Terrain/Obstacle Database to produce a real-time model of the surrounding terrain. This “virtual” picture is then sent to the MFD to provide enhanced situational awareness to the pilot.

The system consists of the 560 GA-EGPWS Processor mounted on the underside of the pilot-side kickplate, a Terrain/Obstacle Database integral to the processor, the Configuration Module integral to the system’s wire harness, and the TAWS annunciator panel mounted on the lower LH portion of the instrument panel.

The 560 GA-EGPWS Processor is powered by 28 VDC through the 5-amp SKYWATCH/TAWS circuit breaker on the Avionics Nonessential Bus.

For a additional system information, *refer to the KGP 560 & 860 EGPWS Pilot’s Guide, P/N 006-18254-001, Revision 4 or later.*

### **System Constraints**

- If there is no terrain data in the database for a particular area, then TAWS alerting is not available for that area. The affected area on the Terrain Awareness Display Page will be colored a MAGENTA dot pattern.
- If the TAWS has been inhibited (e.g. the pilot selected TERR INHIBIT) the system will not give aural alerts. The MFD will display a purple message block with cyan text reading, “TAWS Inhibited”.
- The TAWS will not be available and the TERR INOP annunciator will illuminate if any of the following components are inoperative: MFD, PFD, GPS 1, Transponder, or Attitude Encoder.



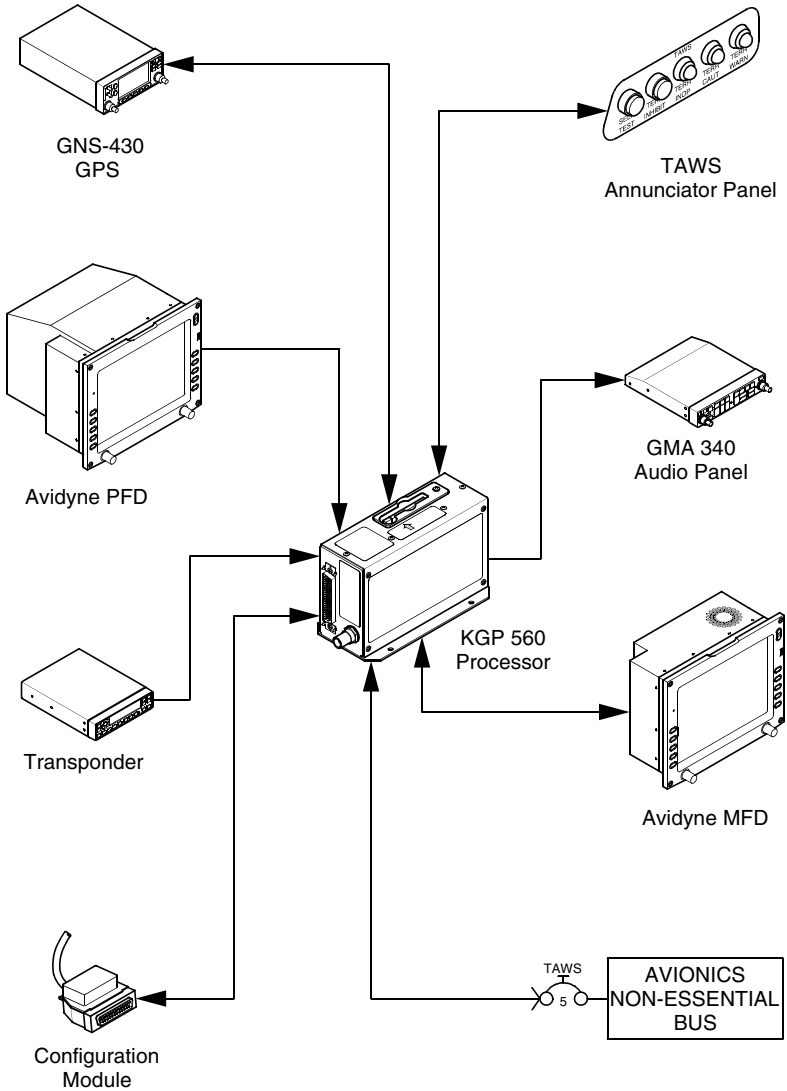

SR20\_FM09\_2031

Figure - 1

**Honeywell KGP 560 TAWS Simplified Schematic**

P/N 13772-121

Original: 07-03-04

## TAWS Annunciator Panel

TAWS terrain annunciations and control functions are incorporated into the Annunciator Panel. The panel consists of a momentary pushbutton switch (SELF TEST), an illuminated pushbutton switch (TERR INHIBIT), and three LEDs for Terrain Warning (TERR WARN), Terrain Caution (TERR CAUT), Terrain Inoperative (TERR INOP).

- SELF TEST - Provides test function for the TAWS.
- TERR INHIBIT - To inhibit nuisance or unwanted warnings at airports that are not in the system database, the pilot may select the TERR INHIBIT switch. Although selection will inhibit all TAWS visual and aural alerts, the Terrain Awareness Display will remain functional with the message "Warnings Inhibited" displayed on the MFD. When activated the switch will illuminate amber.
- TERR INOP - Indicates the TAWS inoperative. When activated the LED will illuminate amber.
- TERR CAUT - Indicates a possible terrain or obstacle conflict within 40-60 seconds. When activated the LED will illuminate amber.
- TERR WARN - Indicates a possible terrain or obstacle conflict within 30 seconds. When activated the LED will illuminate red.

The annunciators are dimmed via the instrument panel lighting dimmer switch. The TAWS annunciator panel is powered by 28 VDC through the 2-amp ANNUN circuit breaker on the Essential Bus

### Alert Priority

When any of the TAWS aural alerts are in progress, all aural TRAFFIC alerts are inhibited.

### Advisory Callout

The advisory callout "*FIVE HUNDRED*", occurs at approximately 500 feet AGL.

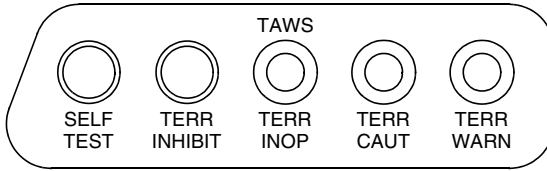

SR20\_FM09\_2033

Annunciator	Color	Function
SELF TEST	N/A	Provides test function for TAWS
TERR INHIBIT	AMBER	All TAWS alerting functions inhibited
TERR INOP	AMBER	Indicates TAWS inoperative
TERR CAUT	AMBER	Possible terrain or obstacle conflict within 40-60 seconds
TERR WARN	RED	Possible terrain or obstacle conflict within 30 seconds

**Figure - 2**  
**TAWS Annunciator Panel**

## MFD Terrain Awareness Display

### • **WARNING** •

Do not use the Terrain Awareness Display for navigation of the aircraft. The TAWS is intended to serve as a situational awareness tool only and may not provide the accuracy fidelity on which to solely base terrain or obstacle avoidance maneuvering decisions.

To select the Terrain Awareness Display Page on the MFD, rotate the page knob to TAWS.

Terrain and obstacle alerts are the most critical situations displayed by TAWS. There are two levels of alerts:

- **Caution Alert** - Possible terrain or obstacle conflict within 40-60 seconds. When triggered, the terrain or obstacle that caused the alert is displayed in bright yellow. In addition, a message describing the nature of the alert is presented in the MFD message bar.
- **Warning Alert** - Possible terrain or obstacle conflict within 30 seconds. When triggered, the terrain or obstacle that caused the alert is displayed in bright red. In addition, a message describing the nature of the alert is presented in the message bar

When a caution or warning alert is active, the display image surrounding the target is enlarged somewhat to allow the terrain or obstacle to be better seen on the display.

If a terrain or obstacle alert occurs while a page other than Terrain Awareness Display Page is being displayed, a terrain or obstacle alert message is displayed in the Message Bar. When the pilot acknowledges this message, the MFD will automatically switch to the Terrain Awareness Display Page.

The message bar will be removed from the display when the TAWS is no longer in alert status, or if the pilot acknowledges the message from the Terrain Awareness Display Page.

### ***Geometric Altitude versus Measured Sea Level***

An indication of MSL-G or Geometric Altitude may appear on the left side of the MFD indicating the height above Measured Sea Level (MSL) calculated from the GPS.

This data serves as the reference for color-coding for the Terrain Awareness Display Page and as an input to the TAWS Look-Ahead algorithm. Because it is derived from GPS, Geometric Altitude may differ from corrected barometric altitude. Therefore, Geometric Altitude may be in error by as much as 100 ft and should not be used for navigation. MSL-G is presented solely to provide the pilot additional situational awareness regarding the true MSL height upon which the TAWS Terrain Display and Alerting is based.

## Self Test

Proper operation of the TAWS can be verified when the aircraft is on the ground as follows:

1. Select the TAWS page on the MFD
2. Clear all caution messages in the lower right corner
3. Ensure that the TERR INHIBIT switch is not engaged, and momentarily push the SELF TEST switch:
  - a. The amber TERR INOP light should be illuminated.
  - b. The amber TERR INOP light should extinguish.
  - c. The red TERR WARN light should be illuminated.
  - d. An aural "EGPWS SYSTEM OK" is enunciated over cockpit speaker.
  - e. The red TERR WARN light should extinguish.
  - f. The amber TERR CAUT light should be illuminated.
  - g. The amber TERR CAUT light should extinguish.
  - h. A terrain self-test pattern should appear on the MFD.
  - i. The terrain self-test should disappear after several sweeps of the terrain display.
  - j. A TAWS Sensor Self Test Caution message should appear in the lower right corner of the MFD.
4. Acknowledge and clear this caution.

# **Section 10**

## **Safety Information**

### **Table of Contents**

Introduction .....	10-3
Cirrus Airframe Parachute System (CAPS) Deployment .....	10-4
Deployment Scenarios.....	10-4
Mid-air Collision .....	10-4
Structural Failure .....	10-4
Loss of Control .....	10-5
Landing Required in Terrain not Permitting a Safe Landing...	10-5
Pilot Incapacitation .....	10-5
General Deployment Information.....	10-5
Deployment Speed .....	10-5
Deployment Altitude .....	10-6
Deployment Attitude .....	10-6
Landing Considerations .....	10-7
Emergency Landing Body Position.....	10-7
Door Position .....	10-7
Water Landings .....	10-8
Post Impact Fire .....	10-9
Ground Gusts .....	10-9

Intentionally Left Blank



## Introduction

The Cirrus Design SR22 is a modern, advanced technology airplane designed to operate safely and efficiently in a flight environment. However, like any other aircraft, pilots must maintain proficiency to achieve maximum safety, utility, and economy.

As the pilot you must be thoroughly familiar with the contents of this Handbook, the Handbook Supplements, the SR22 Flight Checklist, and operational guides and data provided by manufacturers of equipment installed in this airplane. You must operate the airplane in accordance with the applicable FAA operating rules and within the Limitations specified in Section 2 of this Handbook.

The Normal Procedures section of this handbook was designed to provide guidance for day-to-day operation of this airplane. The procedures given are the result of flight testing, FAA certification requirements, and input from pilots with a variety of operational experience. Become fully familiar with the procedures, perform all the required checks, and operate the airplane within the limitations and as outlined in the procedures.

## **Cirrus Airframe Parachute System (CAPS) Deployment**

The Cirrus Airframe Parachute System (CAPS) is designed to lower the aircraft and its passengers to the ground in the event of a life-threatening emergency. However, because CAPS deployment is expected to result in damage to the airframe and, depending upon adverse external factors such as high deployment speed, low altitude, rough terrain or high wind conditions, may result in severe injury or death to the aircraft occupants, its use should not be taken lightly. Instead, possible CAPS activation scenarios should be well thought out and mentally practiced by every SR22 pilot.

The following discussion is meant to guide your thinking about CAPS activation. It is intended to be informative, not directive. It is the responsibility of you, the pilot, to determine when and how the CAPS will be used.

### **Deployment Scenarios**

This section describes possible scenarios in which the activation of the CAPS might be appropriate. This list is not intended to be exclusive, but merely illustrative of the type of circumstances when CAPS deployment could be the only means of saving the occupants of the aircraft.

#### ***Mid-air Collision***

A mid-air collision may render the airplane inoperable by damaging the control system or primary structure. If a mid-air collision occurs, immediately determine if the airplane is controllable and structurally capable of continued safe flight and landing. If it is not, CAPS activation should be considered.

#### ***Structural Failure***

Structural failure may result from many situations, such as: encountering severe gusts at speeds above the airplane's structural cruising speed, inadvertent full control movements above the airplane's maneuvering speed, or exceeding the design load factor while maneuvering. If a structural failure occurs, immediately determine if the airplane is controllable and structurally capable of

continued safe flight and landing. If it is not, CAPS activation should be considered.

### ***Loss of Control***

Loss of control may result from many situations, such as: a control system failure (disconnected or jammed controls); severe wake turbulence, severe turbulence causing upset, severe airframe icing, or sustained pilot disorientation caused by vertigo or panic; or a spiral/spin. If loss of control occurs, determine if the airplane can be recovered. If control cannot be regained, the CAPS should be activated. This decision should be made prior to your pre-determined decision altitude (2,000' AGL, as discussed below).

### ***Landing Required in Terrain not Permitting a Safe Landing***

If a forced landing is required because of engine failure, fuel exhaustion, excessive structural icing, or any other condition CAPS activation is only warranted if a landing cannot be made that ensures little or no risk to the aircraft occupants. However, if the condition occurs over terrain thought not to permit such a landing, such as: over extremely rough or mountainous terrain, over water out of gliding distance to land, over widespread ground fog or at night, CAPS activation should be considered.

### ***Pilot Incapacitation***

Pilot incapacitation may be the result of anything from a pilot's medical condition to a bird strike that injures the pilot. If this occurs and the passengers cannot reasonably accomplish a safe landing, CAPS activation by the passengers should be considered. This possibility should be explained to the passengers prior to the flight and all appropriate passengers should be briefed on CAPS operation so they could effectively deploy CAPS if required.

## **General Deployment Information**

### ***Deployment Speed***

The maximum speed at which deployment has been demonstrated is 133 KIAS. Deployment at higher speeds could subject the parachute and aircraft to excessive loads that could result in structural failure. Once a decision has been made to deploy the CAPS, make all reasonable efforts to slow to the minimum possible airspeed. However,

if time and altitude are critical, and/or ground impact is imminent, the CAPS should be activated regardless of airspeed.

### ***Deployment Altitude***

No minimum altitude for deployment has been set. This is because the actual altitude loss during a particular deployment depends upon the airplane's airspeed, altitude and attitude at deployment as well as other environmental factors. In all cases, however, the chances of a successful deployment increase with altitude. As a guideline, the demonstrated altitude loss from entry into a one-turn spin until under a stabilized parachute is 920 feet. Altitude loss from level flight deployments has been demonstrated at less than 400 feet. With these numbers in mind it might be useful to keep 2,000 feet AGL in mind as a cut-off decision altitude. Above 2,000 feet, there would normally be time to systematically assess and address the aircraft emergency. Below 2,000 feet, the decision to activate the CAPS has to come almost immediately in order to maximize the possibility of successful deployment. At any altitude, once the CAPS is determined to be the only alternative available for saving the aircraft occupants, deploy the system without delay.

### ***Deployment Attitude***

The CAPS has been tested in all flap configurations at speeds ranging from  $V_{so}$  to  $V_a$ . Most CAPS testing was accomplished from a level attitude. Deployment from a spin was also tested. From these tests it was found that as long as the parachute was introduced to the free air by the rocket, it would successfully recover the aircraft into its level descent attitude under parachute. However, it can be assumed that to minimize the chances of parachute entanglement and reduce aircraft oscillations under the parachute, the CAPS should be activated from a wings-level, upright attitude if at all possible.

## Landing Considerations

After a CAPS deployment, the airplane will descend at less than 1700 feet per minute with a lateral speed equal to the velocity of the surface wind. The CAPS landing touchdown is equivalent to ground impact from a height of approximately 13 feet. While the airframe, seats, and landing gear are designed to accommodate the stress, occupants must be prepared for the landing. The overriding consideration in all CAPS deployed landings is to prepare the occupants for the touchdown in order to protect them from injury as much as possible.

### ***Emergency Landing Body Position***

The most important consideration for a touchdown with CAPS deployed is to protect the occupants from injury, especially back injury. Contacting the ground with the back offset attempting to open a door or secure items increases the likelihood of back injury. All occupants must be in the emergency landing body position well before touchdown. After touchdown, all occupants should maintain the emergency landing body position until the airplane comes to a complete stop.

The emergency landing body position is assumed with tightened seat belt and shoulder harness by crossing the arms across the chest, firmly grasping the shoulder harness, and holding the upper torso erect and against the seat backs. The seat cushions contain an aluminum honeycomb core designed to crush under impact to absorb downward loads and help protect the spine from compression injury.

### ***Door Position***

For most situations, it is best to leave the doors latched and use the time available to transmit emergency calls, shut down systems, and get into the Emergency Landing Body Position well before impact. The discussion below gives some specific recommendations, however, the pilot's decision will depend upon all factors, including time to impact, altitude, terrain, winds, condition of airplane, etc.

There is the possibility that one or both doors could jam at impact. If this occurs, to exit the airplane, the occupants will have to force open a partially jammed door or break through a door window using the Emergency Exit Hammer located in the lid of the center armrest. This can significantly delay the occupants from exiting the airplane.

If the pilot elects to touchdown with a door opened, there are several additional factors the pilot must consider: loss of door, possibility of head injury, or injury from an object coming through the open door.

- If a door is open prior to touchdown in a CAPS landing, the door will most likely break away from the airplane at impact.
- If the door is open and the airplane contacts the ground in a rolled condition, an occupant could be thrown forward and strike their head on the exposed door pillar. Contacting the ground in a rolled condition could be caused by terrain that is not level, contacting an obstacle such as a tree, or by transient aircraft attitude.
- With a door open, it is possible for an object such as a tree limb or flying debris to come through the opening and strike an occupant.

**• WARNING •**

If it is decided to unlatch a door, unlatch one door only. Opening only one door will provide for emergency egress as well as reduce risks associated with ground contact. Typically, this would be the copilot's door as this allows the other occupants to exit first after the airplane comes to rest.

CAPS Landing Scenario	Door Position
Empty Copilot Seat	Unlatch Copilot Door
Very Little Time Before Impact	Keep Doors Closed
Fire	Unlatch Copilot Door
Water Landing	Unlatch Copilot Door
Condition Unknown	Keep Doors Closed

***Water Landings***

The ability of the airplane to float after a water landing has not been tested and is unknown. However, since there is the possibility that one or both doors could jam and use of the emergency egress hammer to break out a window could take some time, the pilot may wish to

consider unlatching a door prior to assuming the emergency landing body position in order to provide a ready escape path should the airplane begin to sink.

***Post Impact Fire***

If there is no fire prior to touchdown and the pilot is able to shut down the engine, fuel, and electrical systems, there is less chance of a post impact fire. If the pilot suspects a fire could result from impact, unlatching a door immediately prior to assuming the emergency landing body position should be considered to assure rapid egress.

***Ground Gusts***

If it is known or suspected that ground gusts of approximately 30 knots or more are present in the landing zone, there is a possibility that the parachute could drag the airplane after touchdown, especially if the terrain is flat and without obstacles. In order to assure that the occupants can escape the airplane in the timeliest manner after the airplane comes to rest, the pilot may elect to unlatch the copilot's door for the CAPS landing. Occupants must be in the Emergency Landing Body Position for touchdown. Occupants must not loosen seat belts until the airplane comes to rest. When the airplane comes to rest, the occupants should exit the airplane and immediately move upwind to prevent a sudden gust from dragging the airplane in their direction.

Intentionally Left Blank